



PHYSICS & ENGINEERING EXPERIMENTS

Visit us at 3bscientific.com

Mechanics
Heat

Electricity
Optics

Atomic Physics
Modern Physics



Dr. Johannes Selbach

DEAR CUSTOMERS,

Over the following pages we will be showing you more than 100 experiments for modern physics lessons. This easily understood collection covers the whole spectrum of physics, from classical to modern. You can choose from basic, intermediate and advanced experiments depending on your target group and objectives.

Each experiment includes the following:

- Objectives for the exercises
- Illustration of the experiment set-up
- Treatment of theoretical and experimental background
- Summary of experiment results
- Detailed list of equipment

Our web site www.3bscientific.com can provide you with detailed information on all our apparatus.

We are also happy to respond to any queries made by telephone or by e-mail.

We would also be interested in receiving any of your comments, questions or orders. We are pleased to be working on your behalf to design collections for yet more topics. In doing so, we can tailor our products even more closely to your needs.

Yours sincerely

Dr. Johannes Selbach
Head of Product Management Natural Sciences

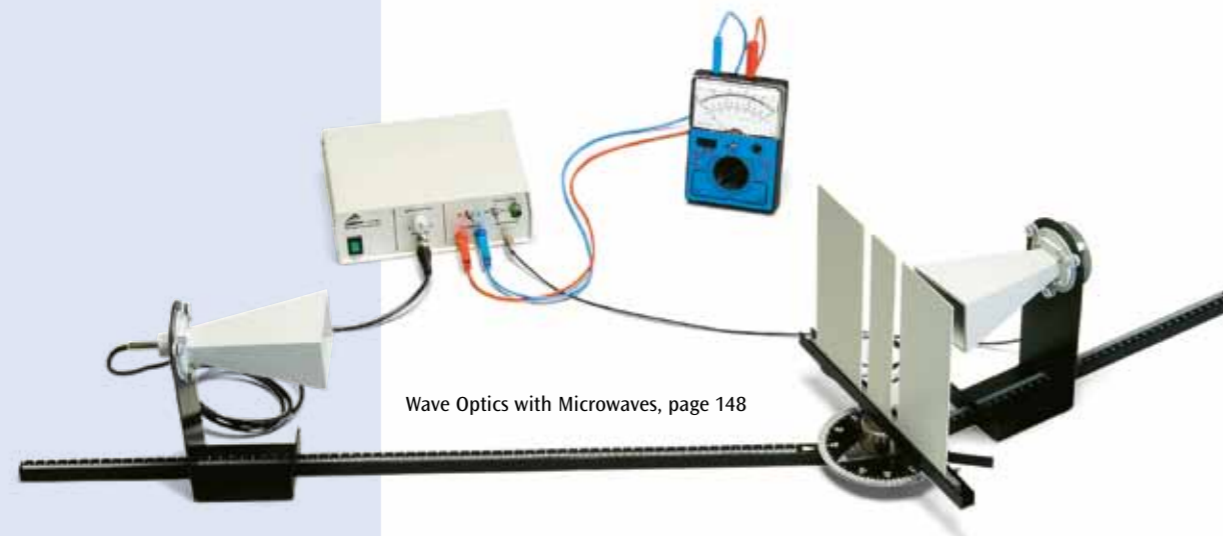

Wave Optics with Microwaves, page 148

Committed to quality

3B Scientific provides you with good quality at fair prices. Our sophisticated quality management complies with the ISO 9001 standards and the Worlddidac Quality Charter and is regularly approved by independent experts.

That's something you can rely on.



CAPTIONS

- 1** → Basic experiment
- 2** → Intermediate experiment
- 3** → Advanced experiment

CONTENT

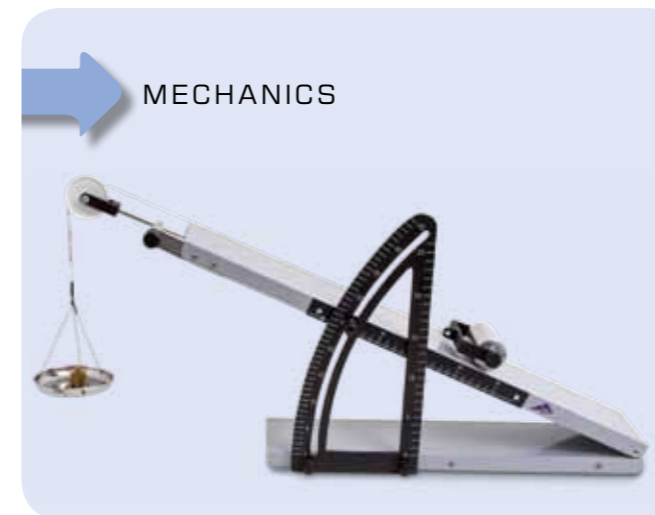

MECHANICS

Sphereometer (UE1010100): 8
Determine the radius of curvature of watch glasses

Lengths and Volumes (UE1010200): 10
Measurement of an irregularly shaped body

Gravitational Constant (UE1010300): 12
Measure the gravitational force and determine the gravitational constant using a Cavendish torsion balance

FORCES

First- and Second-Class Levers (UE1020200): 14
Verification of the law of the lever

Parallelogram of Forces (UE1020300): 16
Experimental investigation of the vector addition of forces

Inclined Planes (UE1020400): 18
Determine the forces acting on an inclined plane

Static and Dynamic Friction (UE1020500): 20
Measurement of friction forces

BUOYANCY

Archimedes' Principle (UE1020850): 22
Determining buoyant updraught as a function of immersion depth

TRANSLATIONAL MOTIONS

Uniformly Accelerated Motion (UE1030250): 24
Measurement of instantaneous velocity as a function of distance covered

Uniformly Accelerated Motion (UE1030260): 26
Record and evaluate motion with uniform acceleration on a roller track

Free Fall (UE1030300): 28
Determine the acceleration due to gravity

Inclined Launch (UE1030400): 30
Plotting the "parabolic" trajectories point by point

Two-Dimensional Collisions (UE1030600): 32
Investigate elastic and inelastic collisions between two objects on a plane

Kepler's Second Law (UE1030700): 34
Confirm the law of equal areas for central force motions

ROTATIONAL MOTIONS

Rotational Motion with Uniform Acceleration (UE1040101): 36
Confirm Newton's equation of motion

Moment of Inertia (UE1040201): 38
Determine the moment of inertia of a horizontal rod with additional weights attached

Moment of Inertia (UE1040205): 40
Determine the moment of inertia for various test bodies

Spinning Motion (UE1040500): 42
Precession and nutation of a gyroscope

OSCILLATIONS AND WAVES

Harmonic Oscillation of a String Pendulum (UE1050101): 44
Measuring the period of oscillation of a string pendulum with bobs of various masses

Elliptical Oscillation of a String Pendulum (UE1050121): 46
Description of elliptical oscillations of a string pendulum as the superimposition of two components perpendicular to one another

Variable-g Pendulum (UE1050201): 48
Measure the period of an oscillating pendulum as a function of the effective acceleration due to gravity

Foucault Pendulum (UE1050250): 50
Demonstrate the rotation of the earth with a Foucault pendulum

Simple Harmonic Oscillations (UE1050311): 52
Measure the oscillations of a coil spring pendulum using an ultrasonic motion sensor

Pohl's Torsion Pendulum (UE1050500): 54
Measurement and analysis of simple harmonic rotary oscillation

Pohl's Torsion Pendulum (UE1050550): 56
Measurement and analysis of forced harmonic rotary oscillation

CONTENT

Coupled Oscillations (UE1050600):.....	58
Record and evaluate oscillation of two identical coupled pendulums	
Mechanical Waves (UE1050700):.....	60
Investigate standing waves along a stretched coil spring and a taut rope	
ACOUSTICS	
Speed of Sound in Air (UE1070310):.....	62
Measuring the propagation time of sound pulses in Kundt's tube	
Speed of Sound in Air (UE1070320):.....	64
Generate and measure standing sound waves in Kundt's tube	
Propagation of Sound in Solids (UE1070530):.....	66
"Determine the speeds of sound propagated by longitudinal and transversal waves in solids"	
Debye Sears Effect (UE1070550):.....	68
Determine the velocity of ultrasonic waves in liquids	
MECHANICS OF LIQUIDS AND GASES	
Falling Sphere Viscosimeter (UE1080350):.....	70
Determine the dynamic viscosity of an aqueous solution of glycerine	
Surface Tension (UE1080400):.....	72
Measure the surface tension by the "break-away" method	



THERMAL EXPANSION	
Thermal Expansion of Solid Bodies (UE2010130):.....	74
Determine the coefficients of expansion for brass, steel and glass	
Anomaly of Water (UE2010301):.....	76
Determine the temperature where water reaches its maximum density	
HEAT TRANSFER	
Heat Conduction (UE2020100):.....	78
Measure conduction of heat in metal bars	
Leslie Cube (UE2020200):.....	80
Measure the heat radiated by a Leslie cube	
INTERNAL ENERGY	
Internal Energy and Mechanical Work (UE2030300):.....	82
Increase of internal energy by mechanical work	
Internal Energy and Electrical Work (UE2030400):.....	84
Increase internal energy by means of electrical work	
GAS LAWS	
Boyle's Law (UE2040100):.....	86
Measuring at room temperature in air as an ideal gas	
Adiabatic Index of Air (UE2040200):.....	88
Determine the adiabatic index C_p/C_v for air using Rüchardt's method	
Real Gas and Critical Point (UE2040300):.....	90
Quantitative analysis of a real gas and determining its critical point	

CONTENT

THERMODYNAMIC CYCLES	
Stirling Motor D (UE2060100):.....	92
Operate a functional model of a Stirling engine as a heat engine	
Stirling Engine G (UE2060250):.....	94
Record a p - V diagram	
Heat Pump (UE2060300):.....	96
Record and analyse the pressure-enthalpy diagram for a compression heat pump	

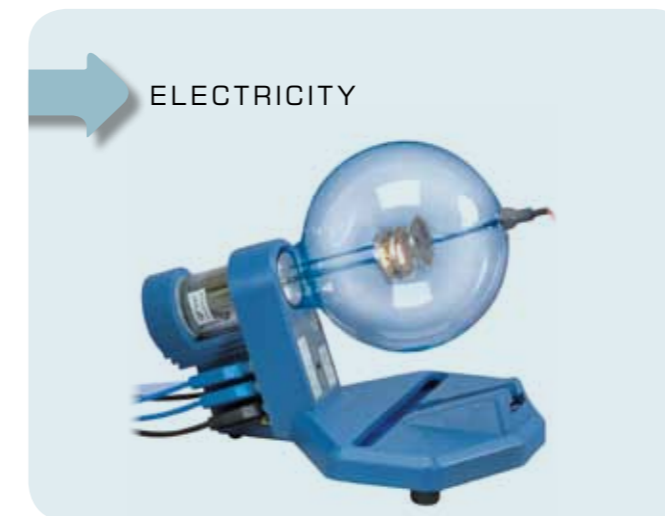

ELECTROSTATICS	
Electric Field in a Plate Capacitor (UE3010700):.....	98
Measure the electric field in a plate capacitor using the electric field meter	
Voltage on a Plate Capacitor (UE3010800):.....	100
"Measure the electrostatic voltage as a function of the distance between the plates"	
CHARGE TRANSPORT AND CURRENT	
Charged Droplets of Water (UE3020100):.....	102
Demonstrate the electric current generated by the motion of charged droplets of water	
Electrical Conductors (UE3020200):.....	104
Determine the electrical conductivity of copper and aluminium	
Wheatstone's Bridge (UE3020300):.....	106
Determine the value of certain resistances	
Ohm's Law (UE3020320):.....	108
Verification of Ohm's law	
Kirchhoff's Laws (UE3020330):.....	110
Measure voltage and current in circuits featuring resistors in series and in parallel.	

Voltage Dividers (UE3020340):.....	112
Measure the voltage and current for a voltage divider with and without a load	
Electrolysis (UE3020700):.....	114
Determine the Faraday constant	
MAGNETIC FIELDS	
Lorentz Force (UE3030300):.....	116
Measure the force on a current-carrying conductor in a magnetic field	
Magnetic Field of a Cylindrical Coil (UE3030500):.....	118
Determine the magnetic field generated by coils of various lengths	
Magnetic Field of the Earth (UE3030700):.....	120
Determine the horizontal and vertical components of the earth's magnetic field	
INDUCTION	
Faraday's Law of Induction (UE3040100):.....	122
Generating a voltage pulse in a conducting loop by the motion of a permanent magnet	
Induction in a Moving Current-loop (UE3040200):.....	124
Measure the induced voltage in a conductor made into a loop as it moves through a magnetic field	
Waltenhofen's Pendulum (UE3040400):.....	126
Demonstrate and investigate how an eddy-current brake works	
Transformers (UE3040500):.....	128
Make measurements on a transformer with and without load	
DC AND AC CIRCUITS	
Charging and Discharging a Capacitor (UE3050101):.....	130
Investigation of how the voltage across a capacitor changes over time when the capacitor is charging or discharging	
Charging and Discharging a Capacitor (UE3050105):.....	132
Determine the charging and discharging times	
Impedance of a Capacitor in an AC Circuit (UE3050111):.....	134
Determine the impedance of a capacitor as a function of capacitance and frequency	
Charging and Discharging a Coil (UE3050201):.....	136
Investigation of how the current through a coil changes over time when the DC supply is turned on and off	
Impedance of a Coil in an AC Circuit (UE3050211):.....	138
Determine inductive impedance as a function of inductance and frequency	

CONTENT

AC Resistance (UE3050301):	140
Determine the AC resistance in a circuit with capacitive and resistive loads	
AC Resistance (UE3050311):	142
Determine the AC resistance in a circuit with inductive and resistive loads	
AC Resistance (UE3050321):	144
Determining impedance in a circuit with an inductive and a capacitive reactance	
LC Resonant Circuits (UE3050400):	146
Investigate the resonance response of a series LC resonant circuit	
ELEKTROMAGNETIC OSCILLATIONS AND WAVES	
Wave Optics with Microwaves (UE3060300):	148
Demonstrate and investigate the phenomena of interference, diffraction and polarisation using microwaves	
ELECTRON TUBES	
Diode (UE3070100):	150
Record the characteristic for a thermionic diode	
Triode (UE3070200):	152
Record the characteristics for a thermionic triode	
Maltese-Cross Tube (UE3070300):	154
Demonstrate the straight-line propagation of electrons in the absence of any field	
Perrin Tube (UE3070400):	156
Determine the polarity of the charge-carriers	
Thomson Tube (UE3070500):	158
Investigate the deflection of electrons by electric and magnetic fields	
Fine-Beam Tube (UE3070700):	160
Determine the specific charge of an electron	
Training Oscilloscope (UE3070800):	162
Study the physical principles of the time-resolved display of electrical signals using an oscilloscope	
Training Oscilloscope II (UE3070850):	164
Demonstrate the superposition of magnetic fields in a vacuum	

ELECTRONICS	
Bipolar Transistors (UE3080200):	166
Measure the characteristic curves relevant to an npn transistor	
Field Effect Transistors (UE3080300):	168
Measure the characteristics of a field effect transistor	

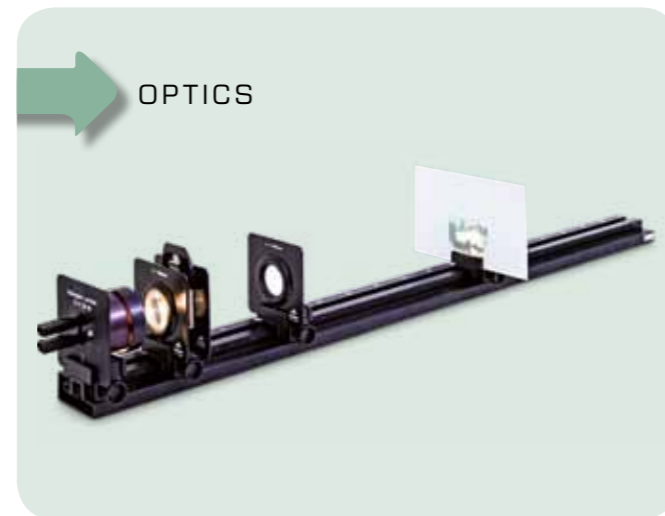

GEOMETRIC OPTICS	
Lens Equation (UE4010100):	170
Determine the focal length of a lens using the Bessel method	

COLOURS	
Transmission Spectra (UE4020400):	172
Record and interpret transmission spectra of transparent bodies	

WAVE OPTICS	
Diffraction at Multiple Slits at Grids (UE4030200):	174
Demonstrate the wave nature of light and determine the wavelength	

Fresnel Biprism (UE4030300):	176
Generating interference between two beams using a Fresnel biprism	

Newton's Rings (UE4030350):	178
Observe Newton's rings in monochromatic light	

Michelson's Interferometer (UE4030410):	180
Demonstrate and investigate how a Michelson interferometer works	

Mach-Zehnder Interferometer (UE4030520):	182
Demonstration of "quantum erasure" in an experiment by analogy	

POLARISATION	
Malus' Law (UE4040100):	184
Verify Malus' law for linearly polarised light	

Optical Activity (UE4040300):	186
Investigate the rotation of the plane of polarisation by sugar solutions	

CONTENT

Faraday Effect (UE4040600):	188
Demonstrate the Faraday effect and determine the Verdet constant for flint glass	

INTENSITY OF RADIATION	
Inverse Square Law (UE4050100):	190
Verify the inverse square law for the intensity of radiation from a source of light	

Stefan-Boltzmann Law (UE4050200):	192
Verify that intensity of radiation is proportional to the fourth power of the temperature, T^4	

VELOCITY OF LIGHT	
Determination of the Velocity of Light (UE4060100):	194
Determine the velocity of light from the transit time of short light pulses	

LASER PHYSICS	
Nd:YAG Laser (UE4070310):	196
Set up and optimise an Nd:YAG laser	

Nd:YAG Laser (UE4070320):	198
Q-switching circuit for Nd:YAG laser with Cr:YAG module	

Nd:YAG Laser (UE4070330):	200
Frequency doubling inside the resonator of a Nd:YAG laser	



INTRODUCTORY EXPERIMENTS IN ATOMIC PHYSICS	
Planck's Constant (UE5010200):	202
Determine Planck's constant using the decelerating voltage method	

Scanning Tunnelling Microscopes (UE5010300):	204
Viewing the atomic structure on the surface of graphite and gold	

Electron Diffraction (UE5010500):	206
Observe the diffraction of electrons on polycrystalline graphite and confirm the wave nature of electrons	

ATOMIC SHELLS	
Line Spectra (UE5020100):	208
Record and interpret the Balmer series of lines for hydrogen other line spectra in the visible region	

Line Spectra (UE5020150):	210
Carry out high-precision measurements of absorption and emission lines	

Franck-Hertz Experiment with Mercury (UE5020300):	212
Record and evaluate the Franck-Hertz curve for mercury	

Franck-Hertz Experiment with Neon (UE5020400):	214
Record and evaluate the Franck-Hertz curve for neon and observe emission of light	

Critical Potentials (UE5020500):	216
Determine the critical potentials of a helium atom	

MAGNETIC RESONANCE	
Electron Spin Resonance (UE5030100):	218
Demonstrate electron spin resonance in DPPH	

Nuclear Magnetic Resonance (UE5030200):	220
Demonstrate and compare nuclear magnetic resonance in glycerine, polystyrene and Teflon	

PHYSIC OF SOLID BODIES/CONDUCTION PHENOMENA	
Electrical Conduction in Semiconductors (UE6020100):	222
Determine band separation in germanium	

Hall-Effect in Semiconductors (UE6020200):	224
Investigating electrical conduction mechanisms in doped germanium with the Hall effect	

Seebeck Effect (UE6020500):	226
Record characteristics for various thermocouples and determine their sensitivity	

X-RAY PHYSICS/DIFFRACTOMETRY	
Bragg Reflection (UE7010100):	228
Determine the lattice constants for crystals with a structure similar to salt (NaCl)	

X-RAY PHYSICS/ENERGY SPECTROSCOPY	
X-Ray Fluorescence (UE7020100):	230
Non-destructive analysis of chemical composition	

MORE PRODUCT RANGES	
Student Experiment Kits (SEK)	232
Biology	236
Geology	240

UE1010100

SPHEROMETER

UE1010100

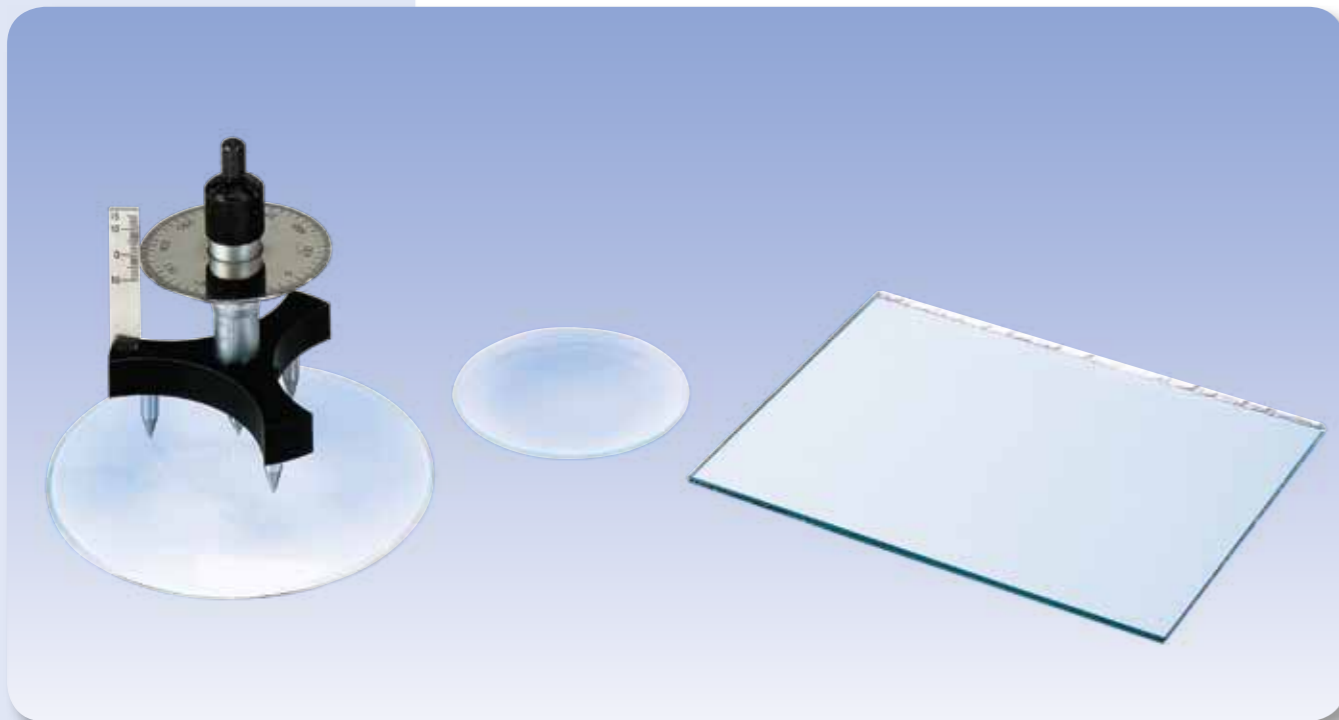

EXPERIMENT PROCEDURE

- Measure the height of the curvature h for two watch glasses for a given distance s between the tips of the spherometer legs.
- Determine the radius of curvature R of both glasses.
- Compare the methods for both convex and concave surfaces.

OBJECTIVE

Determine the radius of curvature of various watch glasses

SUMMARY

From the height h of a spherical surface above a point on a plane defined by the corners of an equilateral triangle, the radius of curvature R of the spherical surface may be determined. This can be done for both convex and concave curvatures of the sphere.

REQUIRED APPARATUS

Quantity	Description	Number
1	Precision spherometer	1002947
1	Plane mirror	1003190
1	Set of 10 watch glass dishes, 80 mm	1002868
1	Set of 10 watch glass dishes, 125 mm	1002869

1

BASIC PRINCIPLES

A spherometer consists of a tripod with the three legs tipped by steel points and forming an equilateral triangle with sides of 50 mm. A micrometer screw, the tip of which is the point to be measured, passes through the centre of the tripod. A vertical rule indicates the height h of the measured point above a plane defined by the tips of the three legs. The height of the measured point can be read off to an accuracy of $1 \mu\text{m}$ with the aid of a circular scale that rotates along with the micrometer screw.

The relationship between the distance r of all three legs from the centre of the spherometer, the radius of curvature R to be determined and the height h of the surface is given by the following equation:

$$(1) \quad R^2 = r^2 + (R-h)^2$$

Rearranging for R gives:

$$(2) \quad R = \frac{r^2 + h^2}{2 \cdot h}$$

The distance r can be calculated from the length s of the sides of the equilateral triangle formed by the legs:

$$(3) \quad r = \frac{s}{\sqrt{3}}$$

Thus the relevant equation for R is as follows:

$$(4) \quad R = \frac{s^2}{6 \cdot h} + \frac{h}{2}$$

EVALUATION

The separation s between the legs of the spherometer is in this case 50 mm. When the height h is small, equation (4) can be simplified to the following:

$$R = \frac{s^2}{6 \cdot h} = \frac{2500\text{mm}^2}{6 \cdot h} \approx \frac{420\text{mm}^2}{h}$$

The scale of the spherometer allows readings for heights between 10 mm and $1 \mu\text{m}$ to an accuracy of $1 \mu\text{m}$, so that radii of curvature of about 40 mm to 400 m can be calculated.

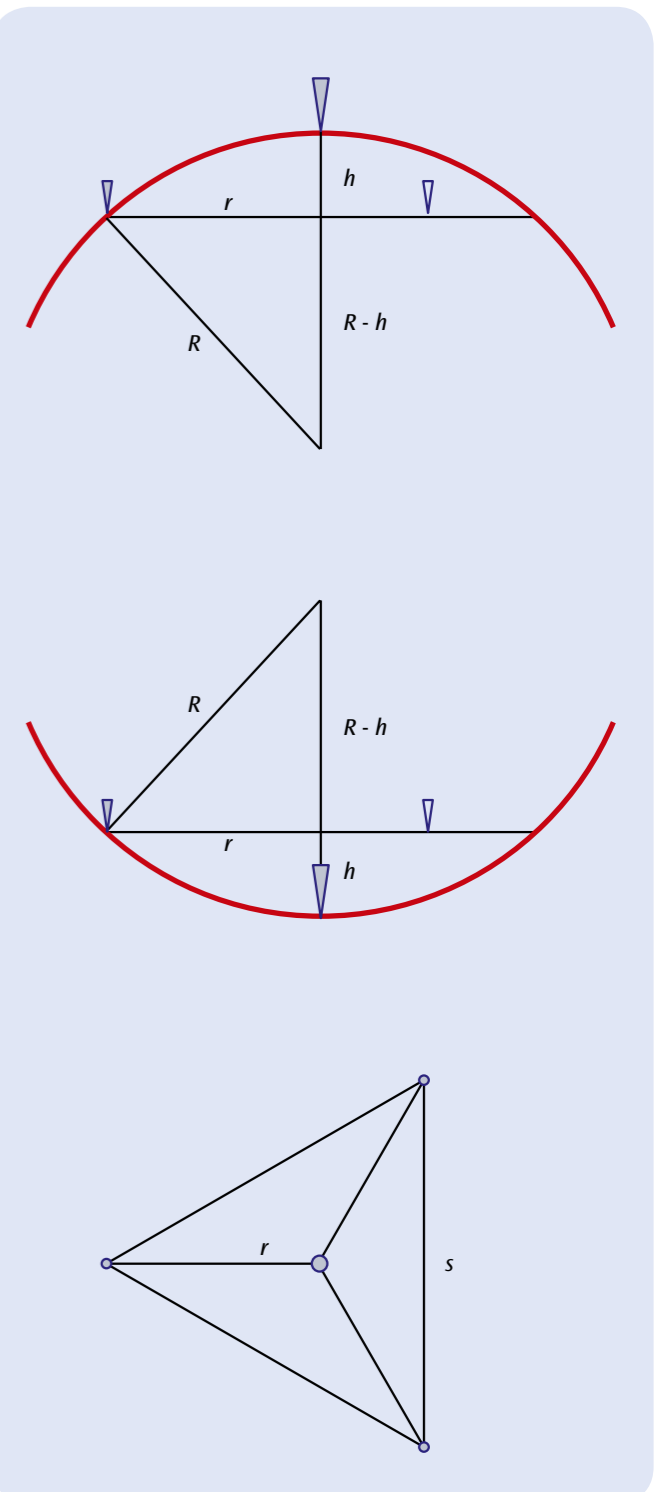

Schematic for measurement of radius of curvature by means of a spherometer
 Top: Vertical cross section for measuring an object with a convex surface
 Middle: Vertical cross section for measuring an object with a concave surface
 Bottom: View from above

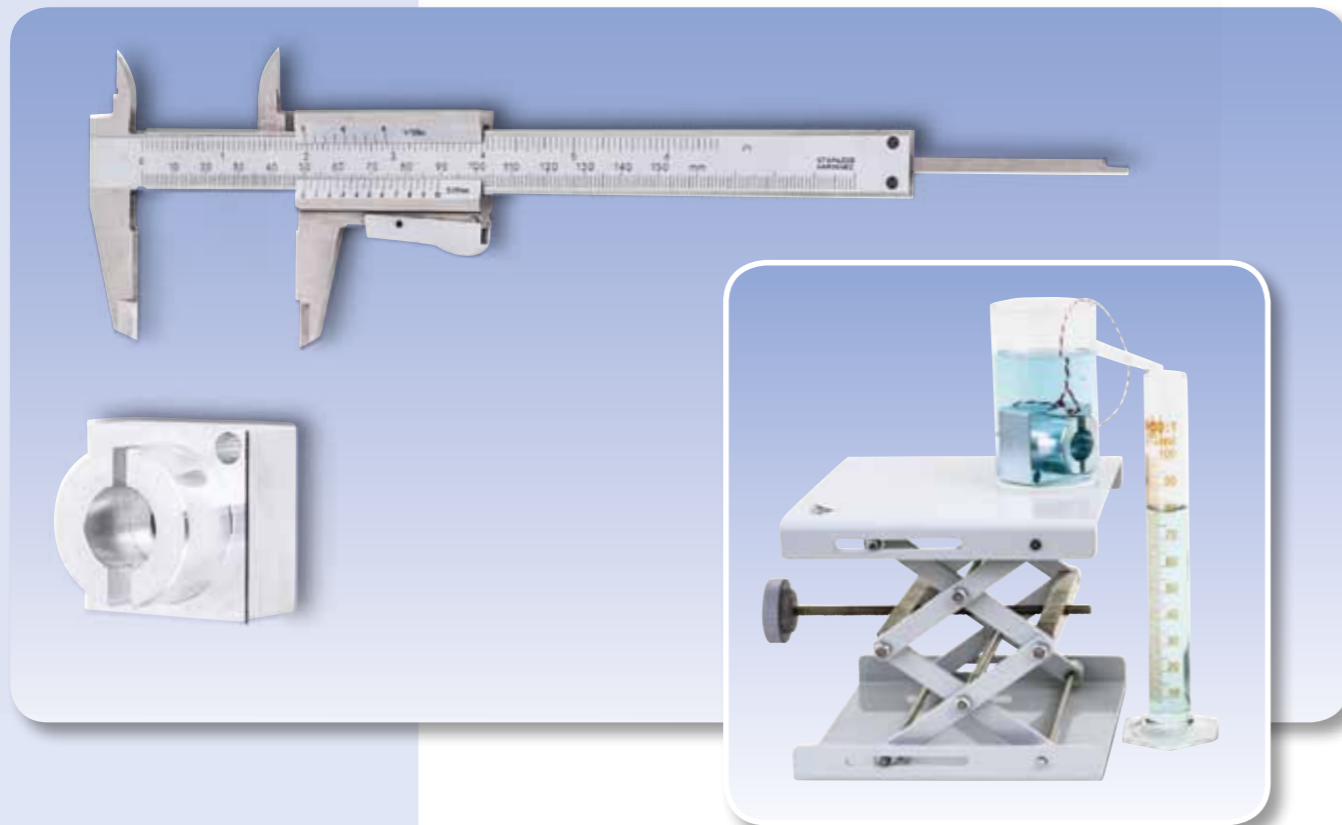

EXPERIMENT PROCEDURE

- Determine the external dimensions of an irregularly shaped body.
- Determine the internal dimensions of an irregularly shaped body.
- Determine depths on an irregularly shaped body.
- Calculate and measure the volume.

OBJECTIVE

Measurement of an irregularly shaped body

SUMMARY

Callipers are used for making precise measurements of quite short lengths. They are suitable for finding internal and external dimensions and depths, as demonstrated in the measurement of an irregularly shaped body. However, calculating a body's volume from the data obtained is comparatively complex. The displacement method is an easier way to determine the volume of an irregularly shaped body.

REQUIRED APPARATUS

Quantity	Description	Number
1	Callipers, 150 mm	1002601
1	Object for Measurement Exercises	1006889
Additionally recommended:		
1	Vessel with Overflow, Transparent	1003518
1	Graduated Cylinder, 100 ml	1002870
1	Laboratory Jack II	1002941
1	Cord for Experiments	1001055
1	Set of 10 Beakers, Tall Form	1002873

1

BASIC PRINCIPLES

One suitable method for determining the volume of an irregularly shaped body is the overflow method. This involves immersing the body in water inside a vessel with an overflow outlet. The water displaced by the body is then collected in a graduated measuring cylinder. The volume of water displaced is equal to the volume V of the body.

In order to avoid systematic errors, callipers must wherever possible be used in such a way that they are not tilted. The accuracy is conventionally increased to resolve fractions of a millimetre by the inclusion of a vernier scale. The full millimetre values are read off from the left of the zero mark on the vernier. The fraction following the decimal point is read off where a mark further over is in line with one of the marks on the vernier. If you have a displacement vessel available, you can determine the volume using the displacement method. The body is completely immersed in a displacement vessel filled with water. The water displaced from this vessel then flows into a measuring cylinder. The volume of water displaced is equal to the volume V of the body.

EVALUATION

As a rule, a dimension is measured multiple times and the accepted result is obtained by taking the average of the individual readings. To calculate the volume, it can be broken down into sub-volumes of regular shapes, which are then added or, in the case of drill holes, for example, subtracted.

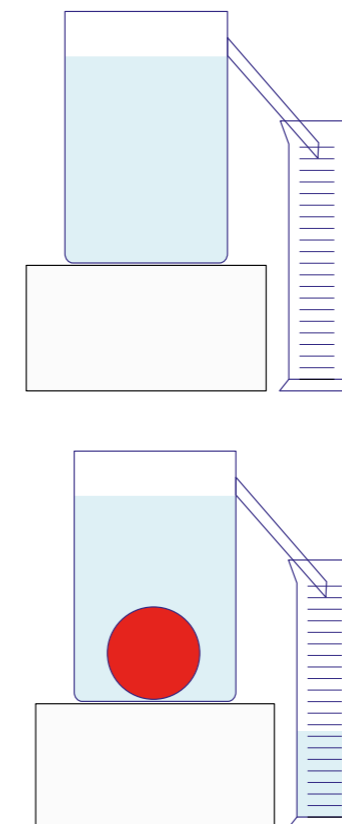

Fig. 6: Schematic illustration of the displacement method

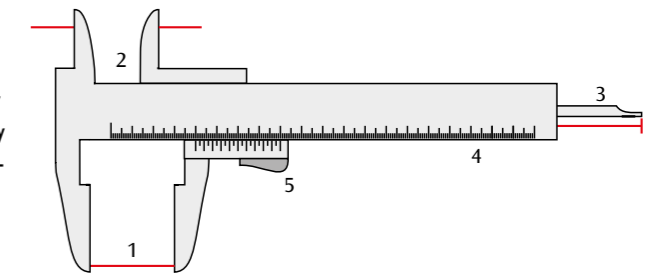

Fig. 1: Prongs for external measurements (1), Prongs (crossed over) for internal measurement (2), Bar for depth measurement (3), Millimetre scale (4), Vernier scale (5)

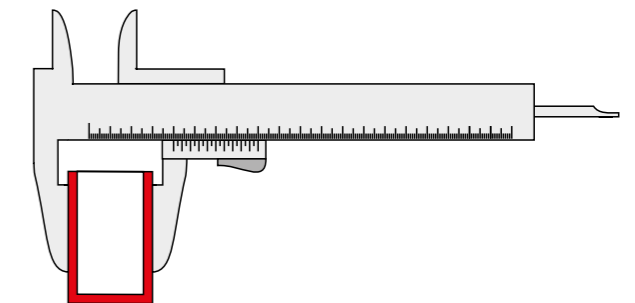

Fig. 2: Determination of external dimensions

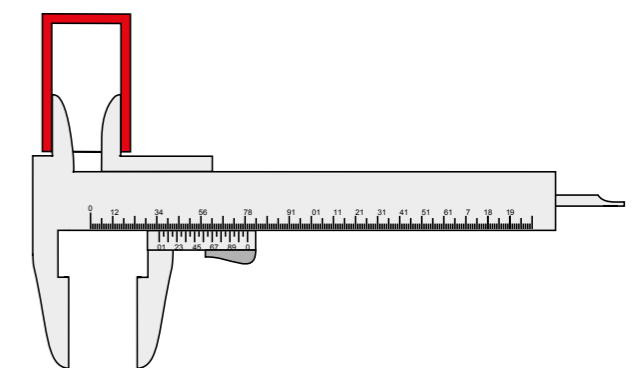

Fig. 3: Determination of internal dimensions

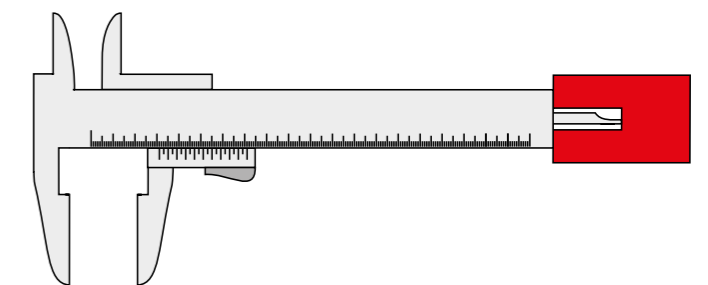

Fig. 4: Determining the depth of a drill hole

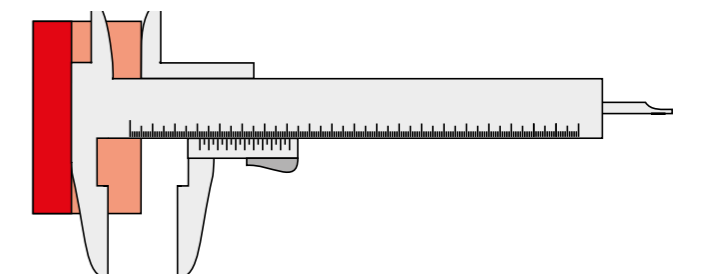
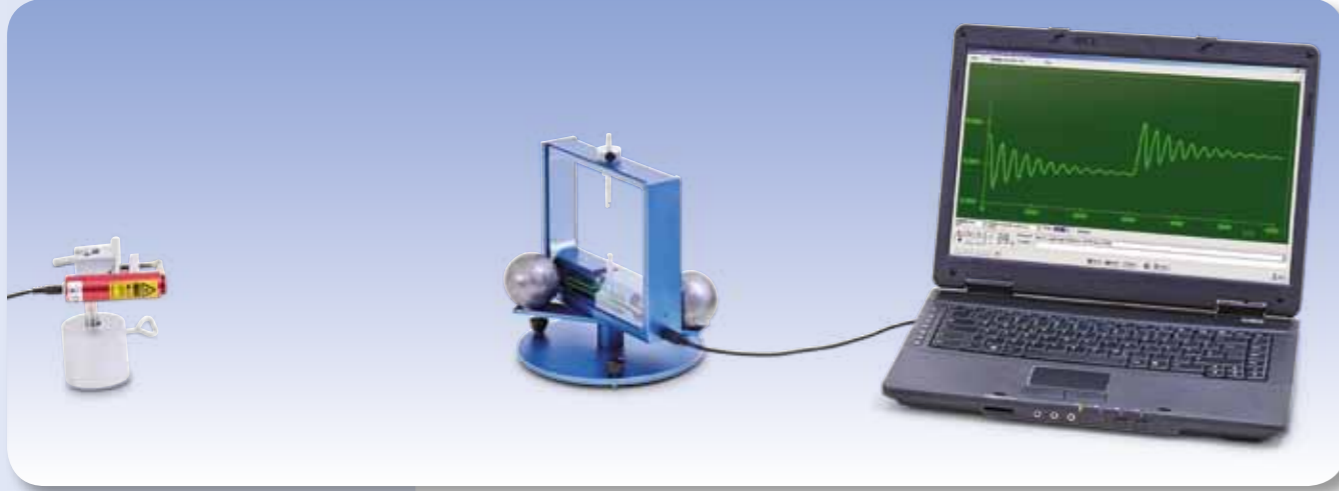

Fig. 5: Determining the height of a step



EXPERIMENT PROCEDURE

- Determine the initial equilibrium position of the torsional pendulum.
- Record the oscillation of the torsional pendulum about the final equilibrium position and determine the period.
- Determine where the final equilibrium position is.
- Calculate the gravitational constant G .

OBJECTIVE

Measure the gravitational force and determine the gravitational constant using Cavendish torsion balance

SUMMARY

The central component of a Cavendish torsion balance is a sensitive torsional pendulum with a pair of small lead spheres attached to it. Two larger lead spheres are then placed near these two small balls in order to attract them. The position of the large spheres thus determines the equilibrium position of the torsional pendulum. If the two large spheres are then moved to a second position which is symmetrical with the first with respect to the two small balls, the torsional pendulum will adopt a new equilibrium position after a short period of settling. By measuring the geometry of the set-up in both positions, it is possible to determine the gravitational constant. The decisive factor in this is the equilibrium between the gravitational force and the restoring torque of the torsional pendulum. Measurements are made of the oscillation of the torsional pendulum using a capacitive differential sensor, which suppresses noise and vibrational components of the signal to a large extent. The tungsten wire from which the pendulum is made is chosen to be so thin that the period of oscillation is of the order of a few minutes, meaning that several oscillations about the equilibrium position may be observed in the space of an hour.

REQUIRED APPARATUS

Quantity	Description	Number
1	Cavendish Torsion Balance	1003337
1	Laser Diode, Red	1003201
1	Barrel Foot, 1000 g	1002834
1	Universal Clamp	1002830
1	Stainless Steel Rod 100 mm	1002932
Additionally recommended:		
1	Callipers, 150 mm	1002601
1	Electronic Scale 5000 g	1003434

BASIC PRINCIPLES

When measuring the gravitational force between two masses in a laboratory, it is inevitably the case that all other masses in the vicinity have a disturbing effect on the results. The Cavendish balance largely gets around this problem since two measurements are made with the masses symmetrically positioned.

The central component of a Cavendish torsion balance is a sensitive torsional pendulum with a pair of small lead spheres attached to it. Two larger lead spheres are then placed near these two small balls in order to attract them. The position of the large spheres thus determines the equilibrium position of the torsional pendulum. If the two large spheres are then moved to a second position which is symmetrical with the first with respect to the two small balls, the torsional pendulum will adopt a new equilibrium position after a short period of settling. By measuring the geometry of the set-up in both positions, it is possible to determine the gravitational constant. The decisive factor in this is the equilibrium between the gravitational force and the restoring torque of the torsional pendulum.

The gravitational force is given by the following:

$$(1) \quad F = G \cdot \frac{m_1 \cdot m_2}{d^2}$$

G : Gravitational constant,
 m_1 : Mass of one small lead sphere,
 m_2 : Mass of one large lead sphere,
 d : Distance between small and large lead spheres at the position where the measurement is made

The force deflects the torsional pendulum from its equilibrium position when the two large spheres are in position for the measurement. The deflecting torque is

$$(2) \quad M_1 = 2 \cdot F \cdot r$$

r : Distance of small lead sphere from its mounting point on the supporting beam

If the torsional pendulum is deflected by an angle φ , there is a restoring torque

$$(3) \quad M_2 = D \cdot \varphi$$

D : Torsion coefficient of tungsten wire

This acts due to the tungsten wire from which the support beam of the torsional balance is suspended. In the equilibrium position, M_1 and M_2 are equal.

The torsional coefficient D can be determined from the period of oscillation T for the oscillation of the torsional pendulum about its equilibrium position.

$$(4) \quad D = J \cdot \frac{4\pi^2}{T^2}$$

The moment of inertia J comprises the moment of inertia J_1 of the two small spheres and the moment of inertia J_k of the supporting beam

$$(5) \quad J = 2 \cdot m_1 \cdot r^2 + \frac{m_b}{12} \cdot (a^2 + b^2)$$

m_b : Mass of support beam

a, b : Length and width of support beam.

For the two large lead spheres, there should be two symmetrical positions where measurements are made. The angles of deflection in these two positions are φ and φ' and the two corresponding deflecting torques are equal but in opposite directions. In equilibrium, equations (2) and (3) therefore imply the following:

$$(6) \quad 4 \cdot F \cdot r = D \cdot (\varphi - \varphi') = D \cdot \Delta\varphi$$

In the course of the experiment the oscillations of the torsional pendulum are measured using a capacitive differential sensor, which suppresses noise and vibrational components of the signal to a large extent. The tungsten wire from which the pendulum is made is chosen to be so thin that the period of oscillation is of the order of a few minutes, meaning that several oscillations about the equilibrium position may be observed in the space of an hour. A mirror attached to the torsional pendulum can be used to set

up a light pointer so that the oscillations are easy to follow with the naked eye. This makes the necessary adjustment and calibration of the balance much easier.

EVALUATION

By rearranging equations (1), (4), (5) and (6):

$$G = \frac{\Delta\varphi}{m_2} \cdot \frac{d^2 \cdot \pi^2}{T^2} \cdot \left(2 \cdot r + \frac{1}{12} \cdot \frac{m_b}{m_1} \cdot \frac{a^2 + b^2}{r} \right)$$

This does not take into account that the two small spheres are also attracted by the more distant large sphere, so that the torque on the torsional pendulum is somewhat reduced in comparison with the calculations made so far. It is not difficult to introduce correction for this into equation (2), since all the distance are known.

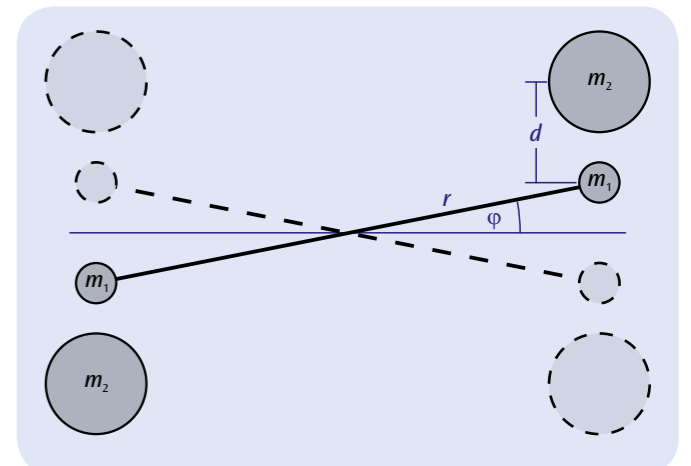

Fig. 1: Schematic of measurement set-up for the Cavendish torsion balance

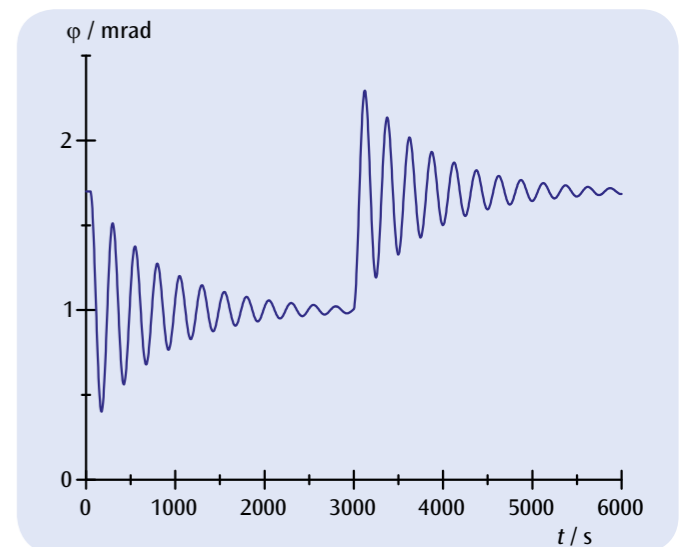

Fig. 2: Angle of deflection of torsional pendulum as a function of time when the measurement position of the two large lead spheres has been changed twice



EXPERIMENT PROCEDURE

- Measure the force F_1 as a function of the load F_2 , the distance between the load and the fulcrum x_2 and the distance between the force and the fulcrum x_1 for a second-class lever.
- Measure the force F_1 as a function of the load F_2 , the distance between the load and the fulcrum x_2 and the distance between the force and the fulcrum x_1 for a first-class lever.

OBJECTIVE

Verification of the law of the lever

SUMMARY

The law of the lever follows from the equilibrium of moments, which works for all three classes of lever. It represents the physical basis for all kinds of mechanical transmission of force.

REQUIRED APPARATUS

Quantity	Description	Number
1	Lever	1008539
1	Precision Dynamometer 2 N	1003105
1	Precision Dynamometer 5 N	1003106

1

BASIC PRINCIPLES

A lever is a fixed body which can rotate around a fixed axis and can be used to lift and move loads. A force or effort is applied at a certain point from the fulcrum in order to move a load or resistance at another point along the lever. With a second-class lever, the effort F_1 and load F_2 are both on the same side of the fulcrum and both the forces act in opposite directions. With a first-class lever, the forces are on different sides of the fulcrum and are both directed the same way.

For both types, the law of the lever follows from the equilibrium of moments:

$$(1) \quad F_1 \cdot x_1 = F_2 \cdot x_2$$

This represents the physical basis for all kinds of mechanical transmission of force.

EVALUATION

From the values measured, calculate in each case the products $F_1 \cdot x_1$ and $F_2 \cdot x_2$ and make a comparison between them.

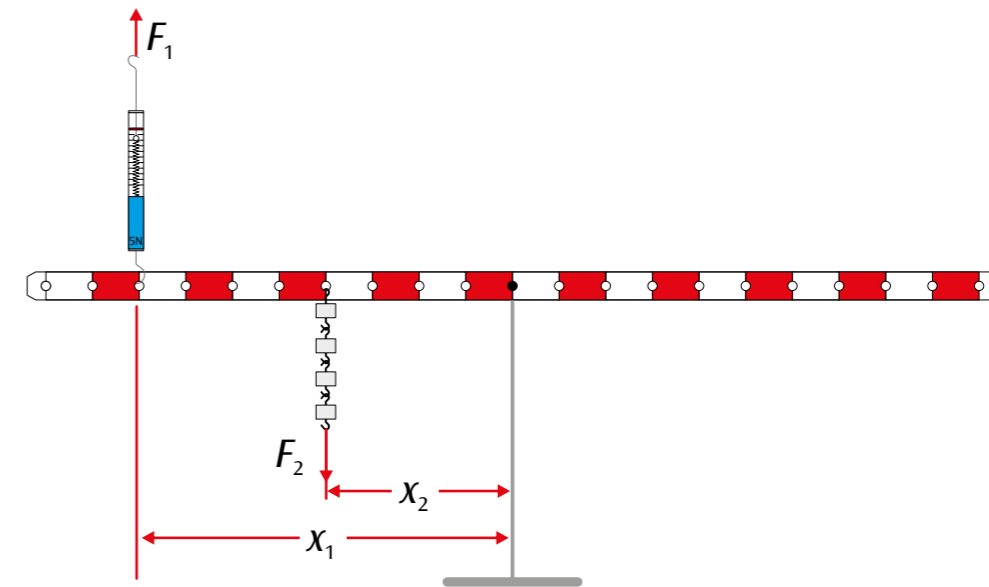

Fig. 1: 2nd-class lever

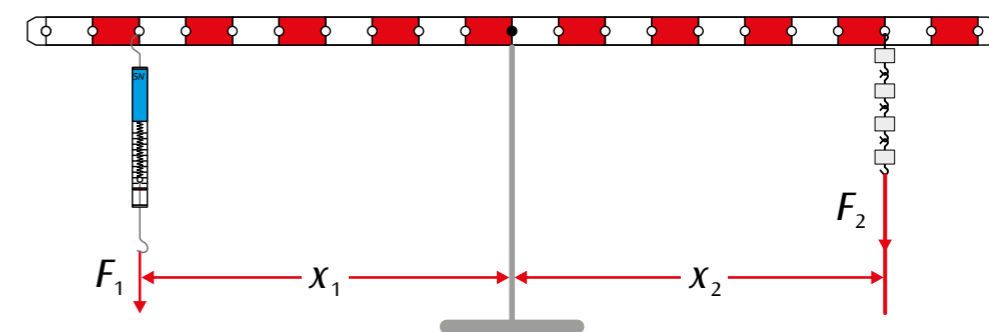

Fig. 2: 1st-class lever



EXPERIMENT PROCEDURE

- Plotting the equilibrium of three arbitrary forces on a graph
- Analytical investigation of the point of equilibrium when forces F_1 and F_2 are symmetrical

OBJECTIVE

Experimental investigation of the vector addition of forces

SUMMARY

The vector addition of forces can be demonstrated in a clear and simple manner on the force table. The point of action of three individual forces in equilibrium is exactly in the middle of the table. Determine the magnitude of the individual forces from the suspended weights and, using a protractor, note the angle of each force vector (the direction of each force). The result of the experiment can be evaluated analytically or represented as a graph.

REQUIRED APPARATUS

Quantity	Description	Number
1	Force Table	1000694

1

BASIC PRINCIPLES

Forces are vectors and can therefore be added using the rules of vector addition. To demonstrate the sum of two vectors on a graph, the point of origin of the second vector is placed on the final point of the first vector. The arrow from the point of origin of the first vector to the final point of the second vector represents the resultant vector. By completing the parallelogram (of which the two vector lines are sides), a diagonal drawn from the original angle to the opposite corner represents the resultant vector (also see Fig. 1).

The vector addition of forces can be demonstrated in a clear and simple manner on the force table. The point of action of three individual forces in equilibrium is exactly in the middle of the table. Determine the magnitude of the individual forces from the suspended weights and, using a protractor, note the angle of each force vector (the direction of each force).

In a state of equilibrium, the sum of the three individual forces is given by:

$$(1) \quad F_1 + F_2 + F_3 = 0$$

$-F_3$ is therefore the sum of individual forces F_1 and F_2 (also see Fig. 2):

$$(2) \quad -F_3 = F = F_1 + F_2$$

The parallel vector components for sum F are given by

$$(3) \quad -F_3 = F = F_1 \cdot \cos \alpha_1 + F_2 \cdot \cos \alpha_2$$

and the vertical components are given by

$$(4) \quad 0 = F_1 \cdot \sin \alpha_1 + F_2 \cdot \sin \alpha_2$$

Equations (3) and (4) provide a mathematical analysis of the vector addition. For the experiment, it is advisable to align force F_3 at an angle of 0° .

For analytical observations, the equilibrium of forces can alternatively be investigated on a graph. To do so, draw lines representing all three forces diverging from the central point of action. Note the magnitude and angle of each force. Subsequently, displace forces F_2 and F_3 along a parallel path till the point of origin is at the end of the preceding vector. The resultant vector is 0 (also see Fig. 3). In the experiment, carry out this procedure for three arbitrary forces, making sure to maintain the state of equilibrium every time.

In the experiment, the analytical observation is restricted to the special situation that the two forces F_1 and F_2 are symmetrical to F_3 .

EVALUATION

Equation (4) is satisfied in a symmetric case ($F_1 = F_2$ and $\alpha_1 = -\alpha_2$). From equation (3) we get the characteristic equation applied in Fig. 4 (for describing the measurement data).

$$F = 2 \cdot F_1 \cdot \cos \alpha_1$$

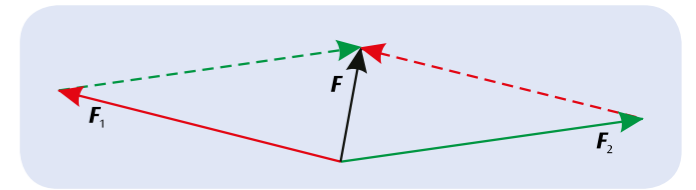

Fig. 1: Vector sum of forces (parallelogram of forces)

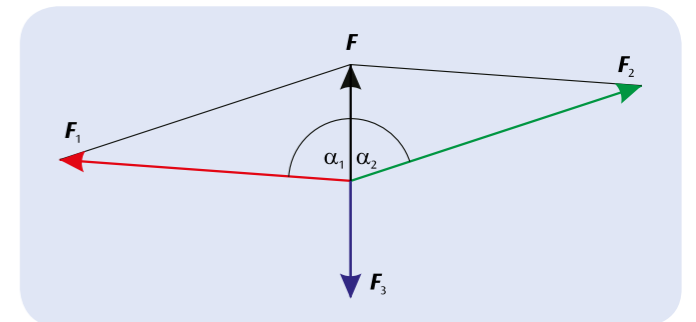

Fig. 2: Determining the sum of vectors of two forces F_1 and F_2 from equilibrium force F_3

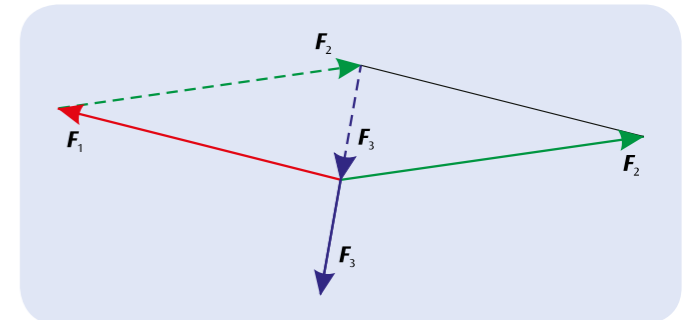

Fig. 3: Graphic investigation of the equilibrium of three arbitrary forces acting in different directions

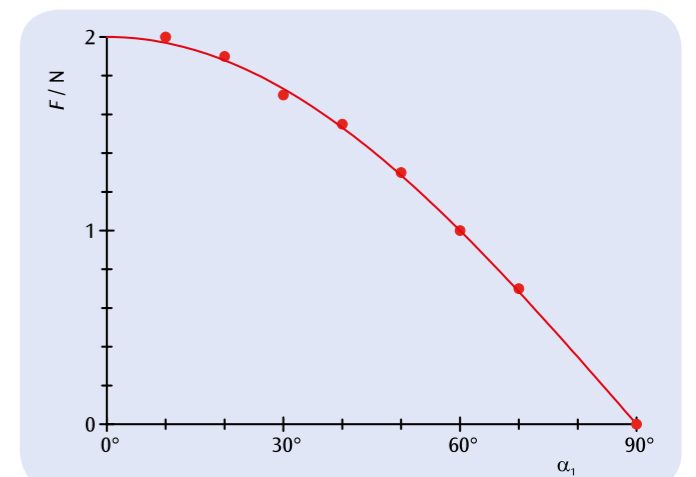

Fig. 4: Measured and calculated sums of two symmetric forces in relation to the angle α_1



EXPERIMENT PROCEDURE

- Measure the component F_1 of the weight of an object which acts down an inclined plane as a function of the angle of inclination α .
- Plot the ratio of the component F_1 to the weight G as a function of $\sin \alpha$.

OBJECTIVE

Determine the forces acting on an inclined plane

SUMMARY

If a body needs to be propelled up an inclined plane, it is not the body's full weight G which needs to be overcome, but only the component which acts parallel to the plane F_1 . The fact that this component is less than the weight is more pronounced the smaller the inclination α of the plane becomes.

REQUIRED APPARATUS

Quantity	Description	Number
1	Inclined Plane	1003213
1	Precision Dynamometer 5 N	1003106
1	Set of Weights 1 g to 500 g	1010189

1

BASIC PRINCIPLES

If a body needs to be propelled up an inclined plane, it is not the body's full weight G which needs to be overcome, but only the component which acts parallel to the plane F_1 . The vector differential between the weight and the component down the plane is represented by the component normal to the plane F_2 , see Fig. 1.

The magnitudes of the forces are given by the following relationships:

$$(1) \quad F_1 = G \cdot \sin \alpha$$

$$(2) \quad F_2 = G \cdot \cos \alpha$$

In this experiment, the body is suspended from a cord which runs over a pulley. The force along the plane is then compensated for by weights on a weight holder suspended from the other end of the cord. Since the friction between the body and the inclined plane is of importance, the value used for the measurements is an average of the lowest and highest values, where the component of the force down the plane is just enough to stop the body sliding down the slope and when it is just enough not to drag it up the slope.

The weight of the body G is determined in advance using a dynamometer. The weight of the weight holder is also taken into account. The angle of inclination α can simply be read from a protractor scale.

EVALUATION

In order to evaluate the data, the ratio of the parallel component of the force F_1 , as measured for various inclination angles α , and the weight of the body G is plotted on a graph against $\sin \alpha$. To within the measurement tolerances, the values all lie on a straight line passing through the origin.

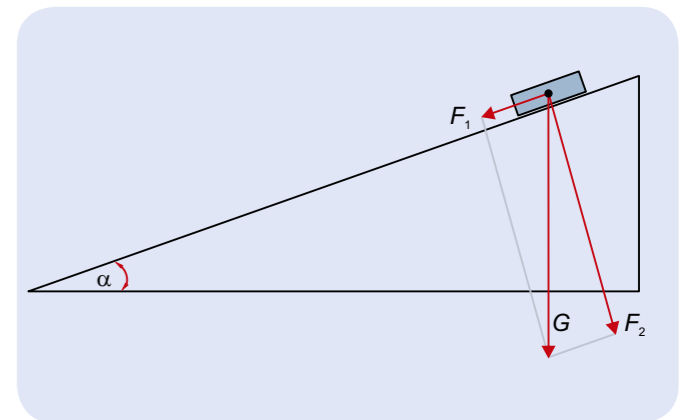

Fig. 1: Resolution of the weight G into vector components parallel to the plane, F_1 , and normal to the plane, F_2

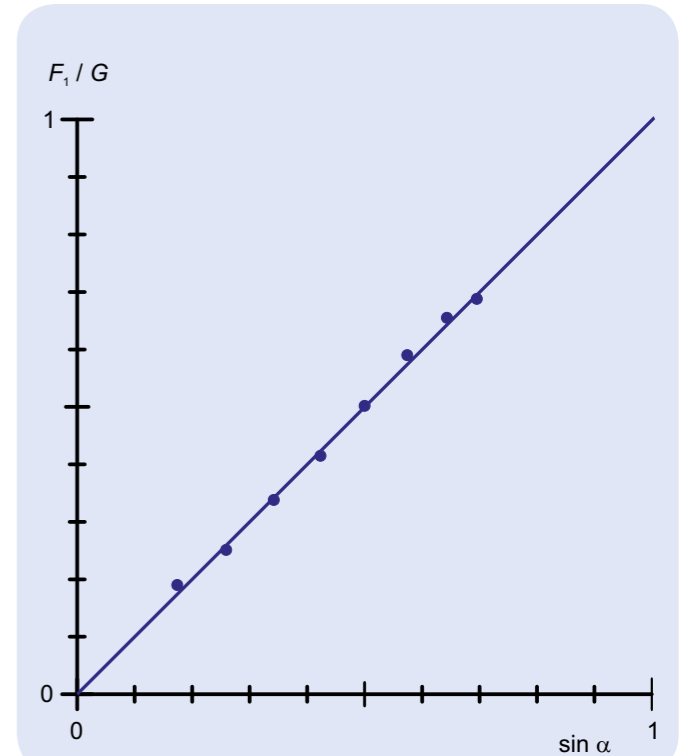
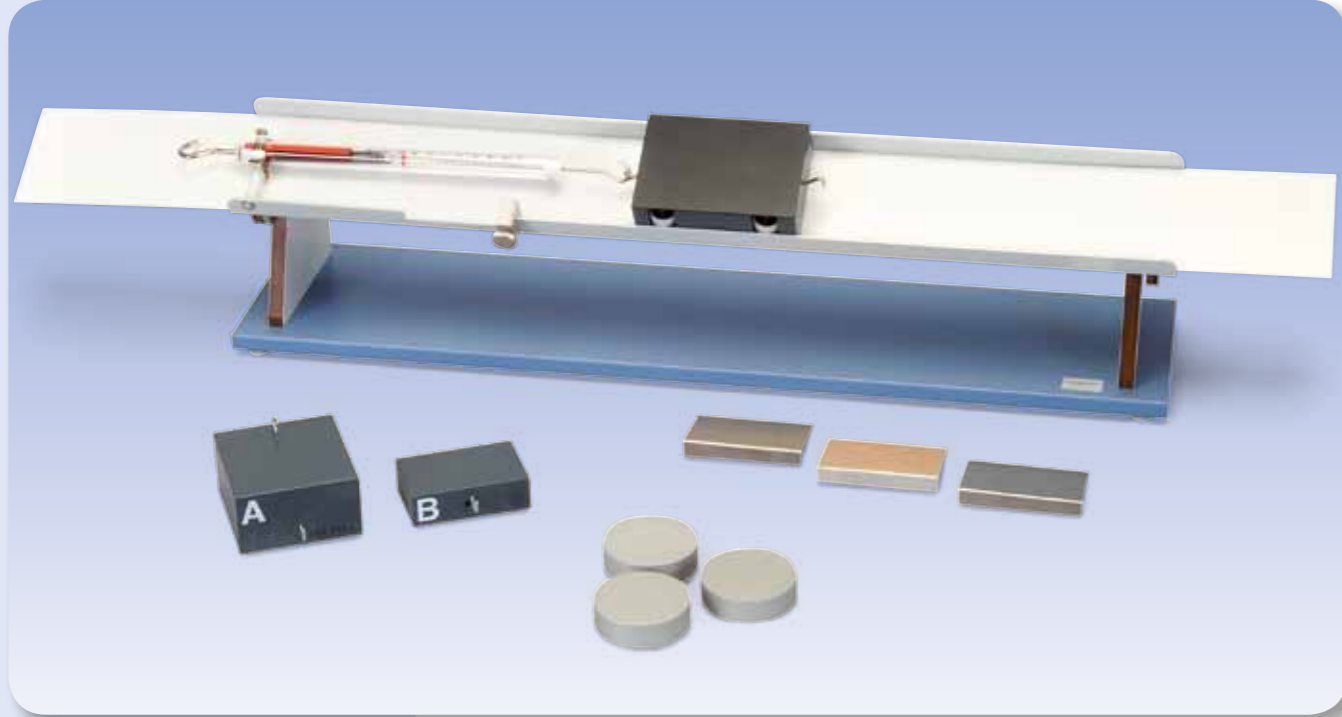

Fig. 2: The ratio between the parallel component F_1 and the weight G as a function of $\sin \alpha$.



EXPERIMENT PROCEDURE

- Comparison of static and dynamic friction.
- Measurement of how dynamic friction depends on the area in contact.
- Measurement of how dynamic friction depends on the combination of materials.
- Measurement of how dynamic friction depends on the perpendicular force between the two surfaces (normal force).

OBJECTIVE

Measurement of friction forces

SUMMARY

In order to measure dynamic friction, a friction measuring apparatus is used. It is composed of movable friction strips, which are pulled from under a stationary rough body connected to a dynamometer at constant speed. In order to vary the effective weight (and therefore the normal force) of the stationary body, the angle of the track can be set to any angle.

REQUIRED APPARATUS

Quantity	Description	Number
1	Friction Measuring Apparatus	1009942



BASIC PRINCIPLES

In order to move an object from rest along a level surface, a force of inertia needs to be overcome. This results from static friction between the body and the surface on which it rests. If, once moving the body is to continue sliding along the surface, a force of F_{Dyn} needs to be applied to overcome the dynamic friction. This force is smaller than the initial force needed to overcome the inertia caused by static friction F_{Stat} , as the degree of contact between the sliding body and the surface beneath is less.

Neither of these forces are dependent on the area in contact, instead being determined primarily by the types of materials and the roughness of the surfaces in contact. They are also proportional to the force that is pushing the surfaces together in a plane perpendicular to that of the surfaces themselves. This is called the normal force F_N (it acts normally, i.e. perpendicular to the surface). The coefficients of static friction μ_{Stat} and dynamic friction μ_{Dyn} are thereby defined as in the following two equations:

$$(1) \quad F_{Stat} = \mu_{Stat} \cdot F_N \quad \text{and} \quad F_{Dyn} = \mu_{Dyn} \cdot F_N$$

In order to measure dynamic friction, an apparatus for measuring such friction is used, in which rough strips are pulled out at constant speed from under a body that remains stationary and is also connected to a dynamometer. Measurements are made for various combinations of materials and contact areas. To alter the normal force the track can be tipped up so that the component of the stationary body's weight that acts normally to the plane of the surface changes.

EVALUATION

If the track is tilted by an angle α , the normal force exerted by a body of mass m in the direction perpendicular to the inclined plane is as follows:

$$F_N = m \cdot g \cdot \cos \alpha$$

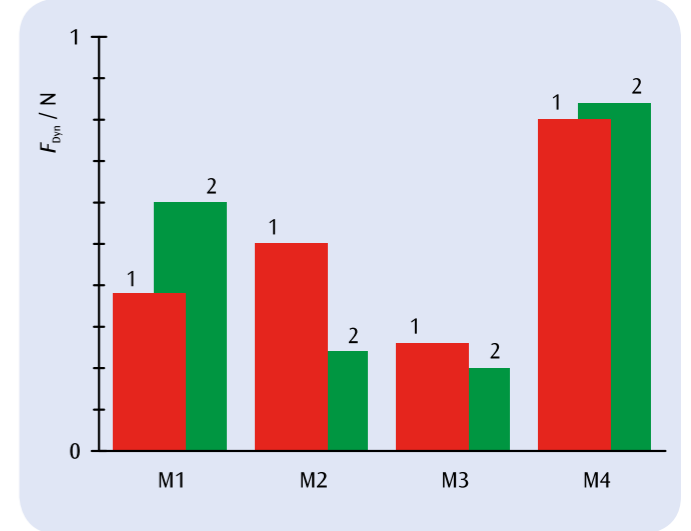

Fig. 1: Dynamic friction F_{Dyn} for four different materials on a smooth surface (1) and a rough surface (2)

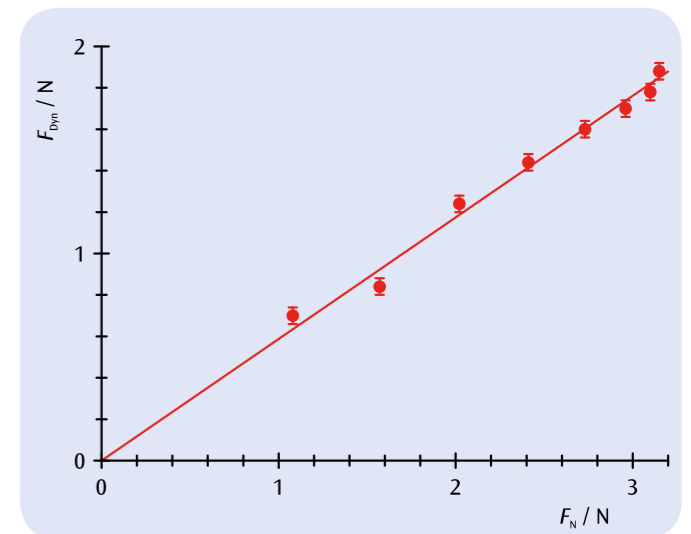

Fig. 2: Dynamic friction F_{Dyn} depending on normal force between the two surfaces F_N

OBJECTIVE

Determining buoyant updraught as a function of immersion depth

SUMMARY

Archimedes' principle states that a body immersed in a fluid experiences an upward force (updraught or force of buoyancy) F_G . The magnitude of this force is equal to the weight of the displaced fluid. For a regularly shaped immersed body, the updraught is proportional to the depth h to which the body is immersed as long as this is smaller than the height H of the body itself.

BASIC PRINCIPLES

Archimedes' principle states that a body immersed in a fluid experiences an upward force (updraught or force of buoyancy) F_G . The magnitude of this force is equal to the weight of the displaced fluid.

For a regularly shaped immersed body with a surface area A and height H , immersed to a depth h , the following applies:

$$(1) \quad F_G = \rho \cdot g \cdot A \cdot h, \text{ where } h < H$$

and

$$(2) \quad F_G = \rho \cdot g \cdot A \cdot H, \text{ where } h > H$$

This experiment uses a block of weight F_0 . This weight acts on a dynamometer at the same time as the block is immersed in water to a depth h , so that the total force present is given by the following:

$$(3) \quad F(h) = F_0 - F_G(h)$$

EVALUATION

The values measured for the updraught F_G as a function of the relative immersion depth h/H all lie on a straight line through the origin with the following gradient: $a = \rho \cdot g \cdot A \cdot H$

The density of water can be calculated from this gradient.

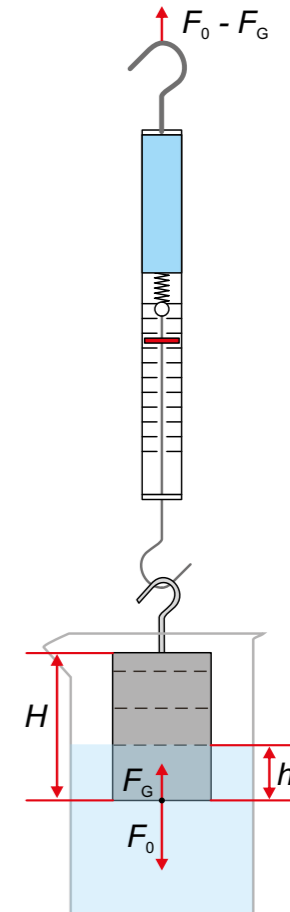

Fig. 2: Schematic representation

EXPERIMENT PROCEDURE

- Measure the force on a body immersed in water.
- Determine the updraught and confirm that it is proportional to the depth to which the body is immersed.
- Determine the density of water.

1
REQUIRED APPARATUS

Quantity	Description	Number
1	Immersion Block Al 100 cm ³	1002953
1	Precision Dynamometer 5 N	1003106
1	Callipers, 150 mm	1002601
1	Set of 10 Beakers, Tall Form	1002873
1	Laboratory Jack II	1002941
1	Tripod Stand 150 mm	1002835
1	Stainless Steel Rod 750 mm	1002935
1	Clamp with Hook	1002828

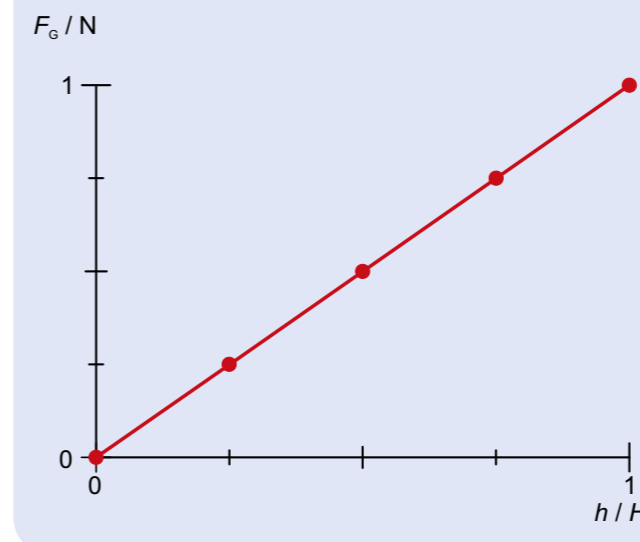
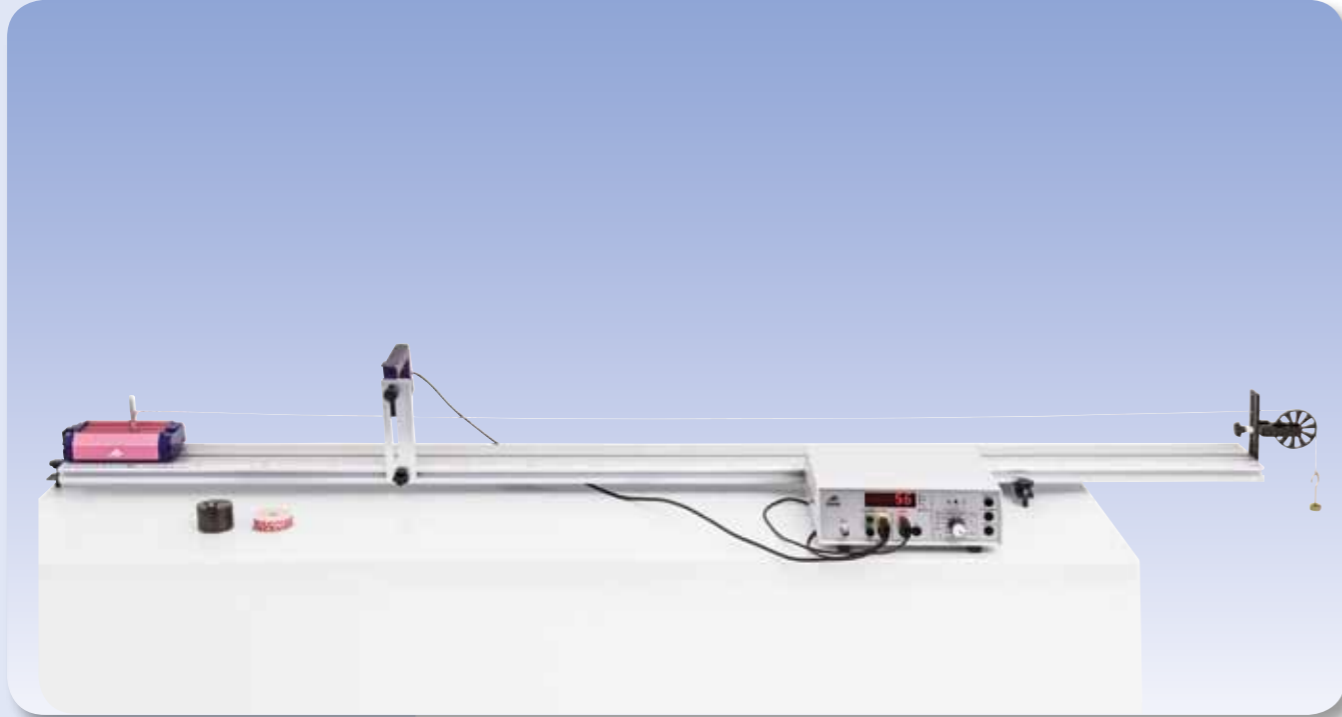

Fig. 1: Updraught F_G as a function of relative immersion depth h/H





EXPERIMENT PROCEDURE

- Investigate uniformly accelerated motion as a function of the accelerating mass.
- Investigate uniformly accelerated motion as a function of the accelerated mass.

OBJECTIVE

Measurement of instantaneous velocity as a function of distance covered

SUMMARY

In the case of uniform acceleration, the instantaneous velocity increases as the distance covered becomes greater. The constant of proportionality between the square of the velocity and the distance covered can be used to calculate the acceleration. This will be investigated in an experiment involving a carriage rolling along a track. In order to measure the instantaneous velocity, a flag of known width attached to the wagon breaks the beam of a photoelectric sensor. The time for which the beam is broken is then measured by means of a digital counter.

REQUIRED APPARATUS

Quantity	Description	Number
1	Trolley Track	1003318
1	Photo Gate	1000563
1	Digital Counter (230 V, 50/60 Hz)	1001033 or
	Digital Counter (115 V, 50/60 Hz)	1001032
1	Set of Slotted Weights, 10 x 10 g	1003227
1	Pair of Safety Experiment Leads, 75 cm	1002849
1	Cord for Experiments	1001055

1

BASIC PRINCIPLES

In the case of uniform acceleration, the velocity v and the distance covered s increase over the course of time t . Thus the velocity increases as the distance becomes greater.

The instantaneous velocity after a period of time t is as follows:

$$(1) \quad v(t) = a \cdot t$$

The distance covered is given by

$$(2) \quad s(t) = \frac{1}{2} \cdot a \cdot t^2$$

This leads to the following conclusions:

$$(3) \quad v(s) = \sqrt{2 \cdot a \cdot s}$$

and

$$(4) \quad v^2(s) = 2 \cdot a \cdot s$$

The instantaneous velocity is given by the following:

$$(5) \quad v = \frac{\Delta s}{\Delta t}$$

In order to measure the instantaneous velocity in this experiment, an interrupter flag of known width Δs is attached to the carriage and breaks the beam of a photoelectric sensor as the carriage passes by it. The time the beam is broken Δt is measured by means of a digital counter.

EVALUATION

Plotting the squares of the instantaneous acceleration for each run, calculated from the times for which the beam is broken, against the distances covered, it is to be expected that there would be a linear relationship in the case of uniform acceleration as described by Equation 4. The gradient of the straight line through the origin plotted is equal to twice the acceleration.



Fig. 1: Schematic representation

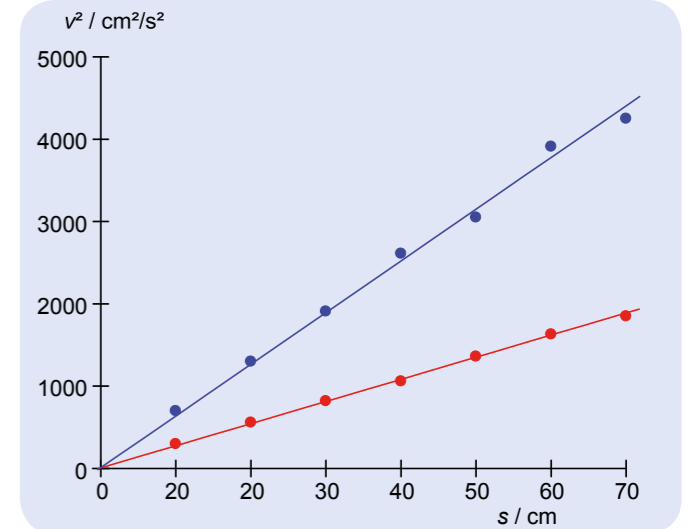

Fig. 2: v^2 - s plot for $m_2 = 500$ g, $m_1 = 10$ g (red), 20 g (blue)

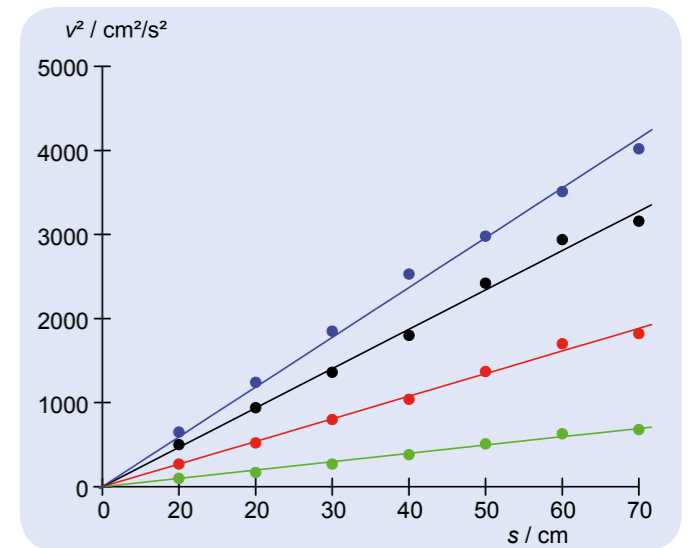

Fig. 3: v^2 - s plot for $m_2 = 1000$ g, $m_1 = 10$ g (green), 20 g (red), 30 g (black), 40 g (blue)



EXPERIMENT PROCEDURE

- Record distance as a function of time.
- Determine the speed at any given point as a function of time.
- Determine the acceleration at any given point as a function of time.
- Determine the average acceleration as a fit to the data and compare with the quotient of force and mass.

OBJECTIVE

Record and evaluate motion with uniform acceleration on a roller track

SUMMARY

When uniformly accelerated motion takes place the velocity at any instant is linearly proportional to the time, while the relationship between distance and time is quadratic. These relationships are to be recorded in an experiment using a roller track with the combination of a spoked wheel employed as a pulley and a photoelectric light barrier.

REQUIRED APPARATUS

Quantity	Description	Number
1	Trolley Track	1003318
1	3B NETlog™ (230 V, 50/60 Hz)	1000540 or
	3B NETlog™ (115 V, 50/60 Hz)	1000539
1	3B NETlab™	1000544
1	Photo Gate	1000563
1	Cord, 100 m	1007112
1	Set of Slotted Weights, 10 x 10 g	1003227

1

BASIC PRINCIPLES

The velocity v and acceleration a at any given point in time are defined as first and second-order differentials of the distance s covered after a time t . This definition can be verified experimentally by using differential quotients instead of the actual differentials on a plot with the distance sampled at close intervals where the displacement points s are matched with measurements of time t_n . This provides a framework for experimentally investigating, for example, uniformly accelerated motion.

For constant acceleration a , the instantaneous velocity v increases in proportion to the time t , assuming the centre of gravity was initially at rest:

$$(1) \quad v = a \cdot t$$

The distance covered s increases in proportion to the square of the time:

$$(2) \quad s = \frac{1}{2} \cdot a \cdot t^2$$

Constant acceleration results from a constant accelerating force F , as long as the mass m being accelerated does not change:

$$(3) \quad a = \frac{F}{m}$$

These relationships are to be investigated in an experiment using a carriage on a roller track. The carriage is accelerated uniformly because it is pulled by a thread subjected to a constant force, which is provided by a weight of known mass attached to the other end of the thread, see Fig. 1. The pulley for the thread takes the form of a spoked wheel and the spokes periodically interrupt a photoelectric light barrier. A measuring interface is attached which measures the times t_n when the spokes break the beam and sends that data to a computer for evaluation. The evaluation software calculates the distance covered at times t_n , along with the corresponding values for the time and acceleration at that instant.

$$(4a) \quad s_n = n \cdot \Delta$$

$$(4b) \quad v_n = \frac{\Delta}{t_{n+1} - t_{n-1}}$$

$$(4c) \quad a_n = \frac{\frac{\Delta}{t_{n+1} - t_n} - \frac{\Delta}{t_n - t_{n-1}}}{\frac{t_{n+1} - t_{n-1}}{2}}$$

$\Delta = 20$ mm: distance between spokes

Measurements are made for various combinations of accelerating force F and accelerated mass m .

EVALUATION

The evaluation software can display the values s , v and a as a function of time t . Applicability of equations (1) and (2) is checked by matching the results with various expressions using the acceleration a as a parameter. If m_1 is the mass of the carriage and m_2 is the mass of the weight hanging from the thread. Since the mass m_2 also undergoes acceleration, then the values to be used in equation (3) are:

$$F = m_2 \cdot g \quad \text{and} \quad m = m_1 + m_2$$

This implies:

$$a = \frac{m_2}{m_1 + m_2} \cdot g$$

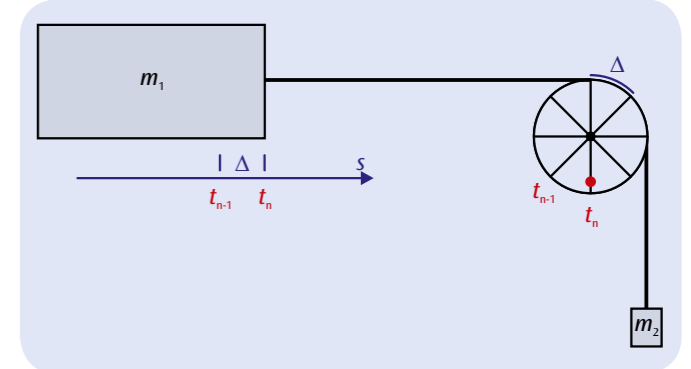

Fig. 1: Schematic illustration of measuring principle

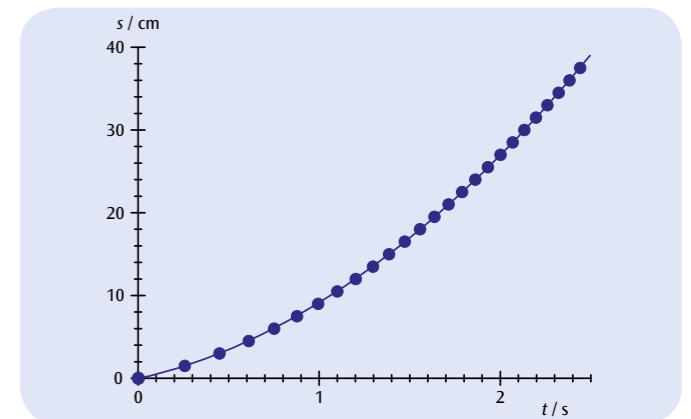

Fig. 2: Distance as a function of time

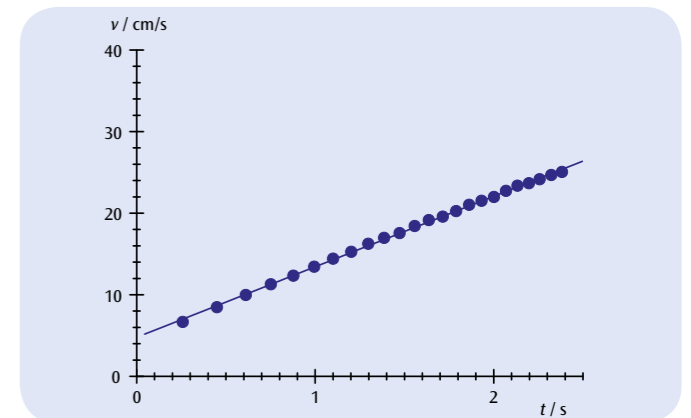

Fig. 3: Velocity as a function of time

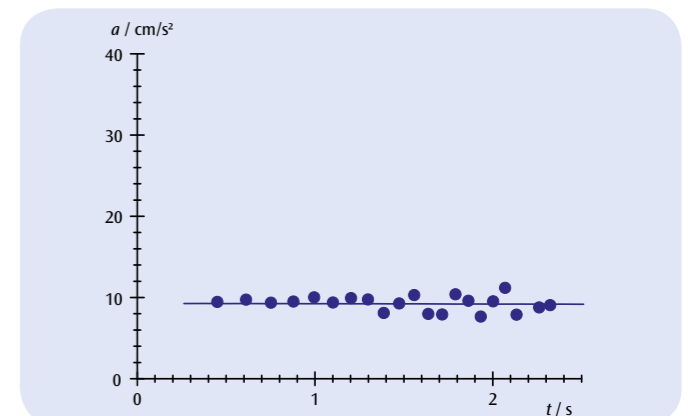
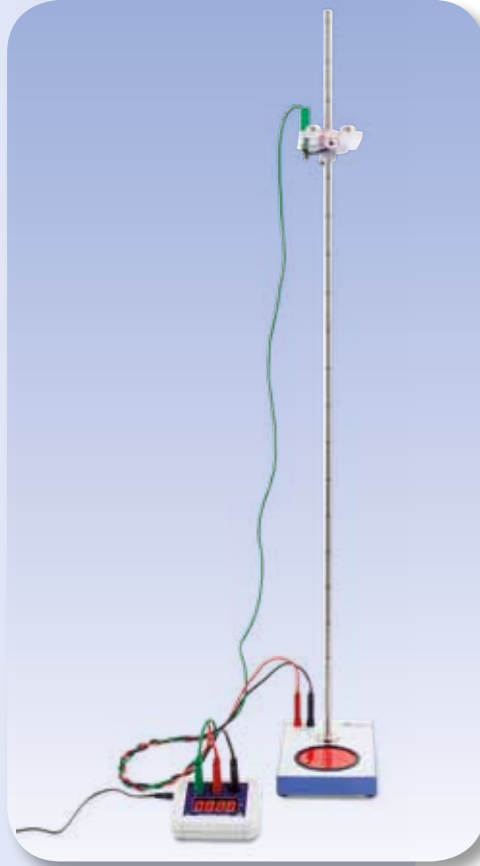

Fig. 4: Acceleration as a function of time



EXPERIMENT PROCEDURE

- Measure the time t that a ball takes to fall a distance h between a release mechanism and a target plate at the bottom.
- Draw points for a displacement/time graph for a uniformly accelerating motion.
- Verify that the distance fallen is proportional to the square of the time.
- Calculate the acceleration due to gravity g .

OBJECTIVE

Determine the gravitational acceleration

SUMMARY

In free fall the distance fallen h is proportional to the square of the time t taken to fall that distance. The coefficient of that proportionality can be used to calculate the gravitational acceleration g .

REQUIRED APPARATUS

Quantity	Description	Number
1	Free-fall Apparatus	1000738
1	Millisecond Counter (230 V, 50/60 Hz)	1012833 or
	Millisecond Counter (115 V, 50/60 Hz)	1012832
1	Set of 3 Safety Experiment Leads	1002848

1

BASIC PRINCIPLES

If a body falls to the ground in the Earth's gravitational field from a height h , it undergoes a constant acceleration g , as long as the speed of the fall is slow so that friction can be ignored. Such a falling motion is called free fall.

In this experiment a steel ball is suspended from a release mechanism. As soon as it is released into free fall, an electronic timer is started. After it has fallen a distance h the ball hits a target plate at the bottom which stops the time measurement at a time t .

Since the ball is not moving before it starts to fall at time $t_0 = 0$ its initial velocity is zero, i.e. $v_0 = 0$. Therefore the distance covered in time t is given as follows

$$(1) \quad h = \frac{1}{2} \cdot g \cdot t^2$$

EVALUATION

First variant:

Fall times change in the ratio 2:1 if the height of the fall changes in the ratio 4:1. This confirms that the height is proportional to the square of the time.

Second variant:

Measurements for various heights of fall should be plotted on a displacement/time graph. The height h is not linearly proportional to the time t , as can be confirmed by attempting to match the curve to a line then to a parabola. To obtain a straight line, the height should be plotted against the square of the time. The straight-line relationship found in this way confirms equation (1). The gradient of such a line corresponds to the acceleration due to gravity.

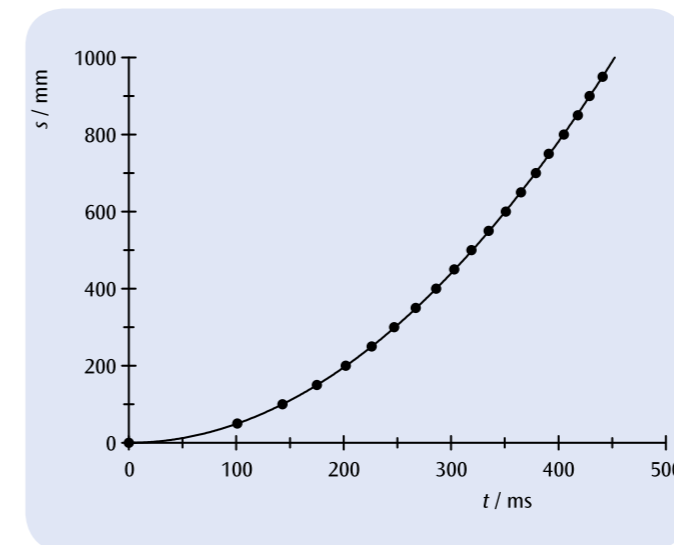

Fig. 1: Time-displacement diagram for free fall

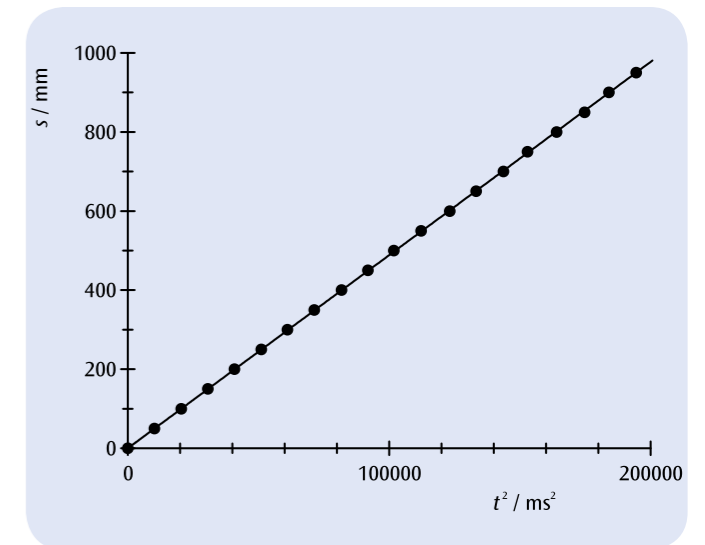
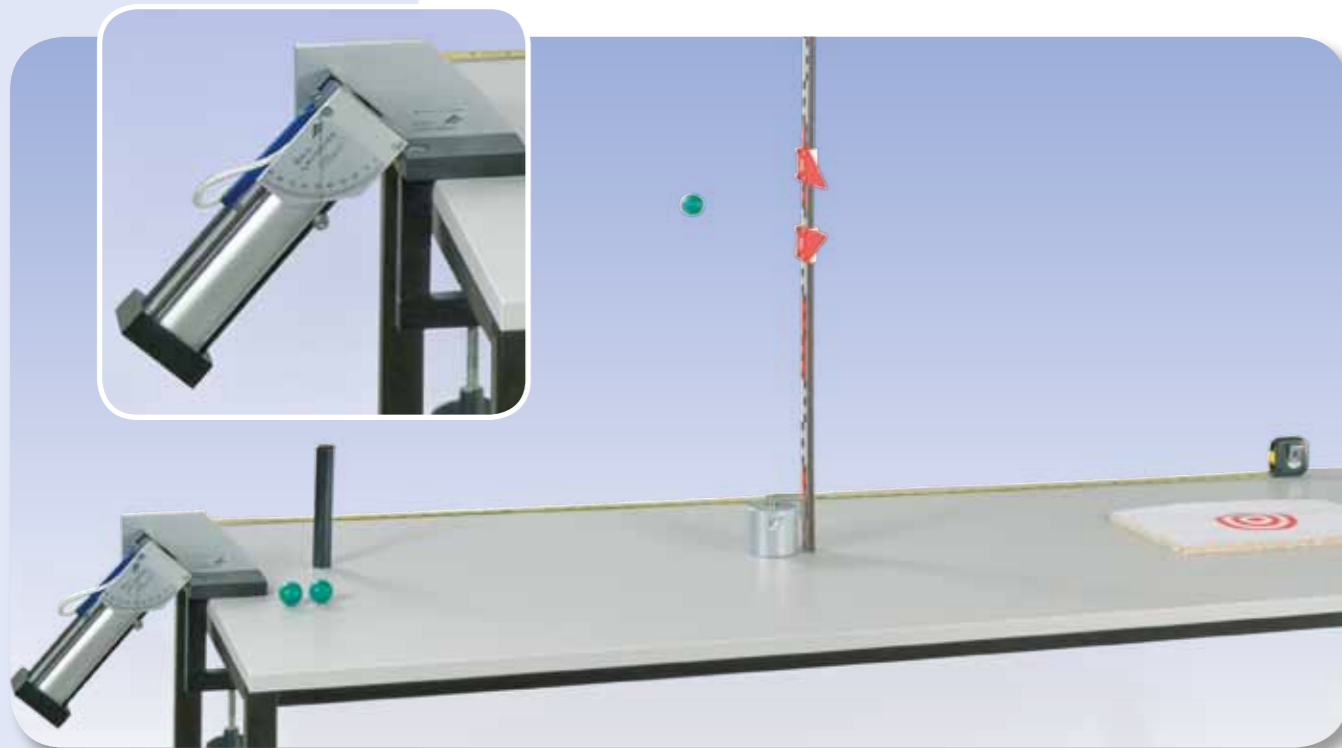

Fig. 2: Height plotted against the square of time



EXPERIMENT PROCEDURE

- Measuring the width of the trajectory as a function of the throwing angle and the initial velocity.
- Calculating the initial velocity from the maximum width of the trajectory.
- Point-by-point plotting of the “parabolic” trajectory as a function of the throwing angle and the initial velocity.
- Verification of the principle of superposition.

OBJECTIVE

Plotting the “parabolic” trajectories point by point

SUMMARY

The motion of a ball that is thrown upward at an angle to the horizontal in the earth’s gravitational field follows a parabolic curve whose height and width depend on the throwing angle and the initial velocity. The curve is measured point by point using a height scale with two pointers.

REQUIRED APPARATUS

Quantity	Description	Number
1	Projectile Launcher	1002654
1	Clamp for Projectile Launcher	1002655
1	Vertical Ruler, 1 m	1000743
1	Set of Riders for Rulers	1006494
1	Barrel Foot, 900 g	1002834
1	Pocket Measuring Tape, 2 m	1002603

1

BASIC PRINCIPLES

According to the principle of superposition, the motion of a ball that is thrown upward at an angle to the horizontal in the earth’s gravitational field is the combination of a motion at a constant speed in the direction of throwing and a gravitational falling motion. This results in a parabolic flight curve, whose height and width depend on the throwing angle α and the initial velocity v_0 .

To calculate the theoretical flight curve, for simplicity we take the centre of the spherical ball as the origin of the co-ordinate system, and we neglect the frictional drag of the air on the ball. Thus the ball retains its initial velocity in the horizontal direction

$$(1) \quad v_x(0) = v_0 \cdot \cos \alpha$$

and therefore at time t the horizontal distance travelled is

$$(2) \quad x(t) = v_0 \cdot \cos \alpha \cdot t$$

In the vertical direction, under the influence of the gravitational field the ball is subjected to gravitational acceleration g . Therefore, at time t its vertical velocity is

$$(3) \quad v_y(t) = v_0 \cdot \sin \alpha - g \cdot t$$

and the vertical distance travelled is

$$(4) \quad y(t) = v_0 \cdot \sin \alpha \cdot t - \frac{1}{2} \cdot g \cdot t^2$$

The flight curve of the ball has the form of a parabola, as it conforms to the equation

$$(5) \quad y(x) = \tan \alpha \cdot x - \frac{1}{2} \cdot \frac{g}{(v_0 \cdot \cos \alpha)^2} \cdot x^2$$

At time t_1 given by

$$(6) \quad t_1 = \frac{v_0 \cdot \sin \alpha}{g}$$

the ball reaches the highest point of the parabola, and at time t_2 given by

$$(7) \quad t_2 = 2 \cdot \frac{v_0 \cdot \sin \alpha}{g}$$

it is again at the initial height 0. Thus, the height of the parabola is

$$(8) \quad h = y(t_1) = \frac{v_0^2}{2 \cdot g} \cdot \sin^2 \alpha$$

and the width is

$$(9) \quad s = x(t_2) = 2 \cdot \frac{v_0^2}{g} \cdot \sin \alpha \cdot \cos \alpha$$

In the experiment, the flight curves of a ball are measured point by point as a function of the throwing angle and the initial velocity, using a height scale with two pointers.

EVALUATION

The maximum width of all the flight curves, s_{\max} , is reached when the throwing angle α is 45° . From this maximum width, it is possible to calculate the initial velocity. By using Equation 9, we get

$$v_0 = \sqrt{g \cdot s_{\max}}$$

An exact analysis of the experimental data shows that the frictional drag of the air on the ball must be taken into account, and that the flight curves actually depart slightly from the parabolic shape.

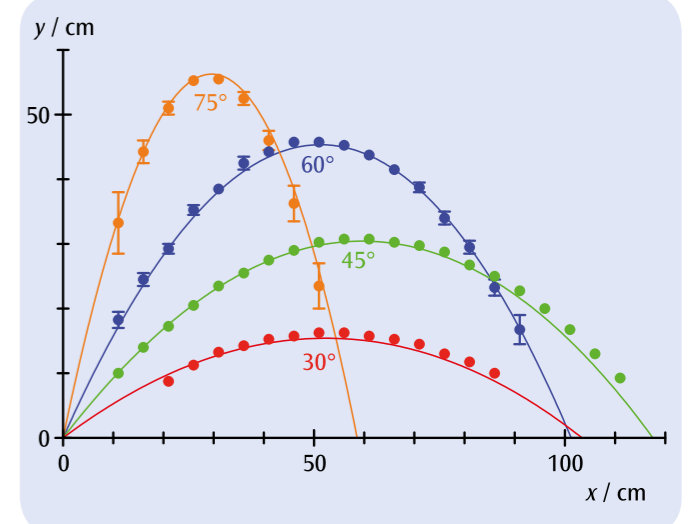
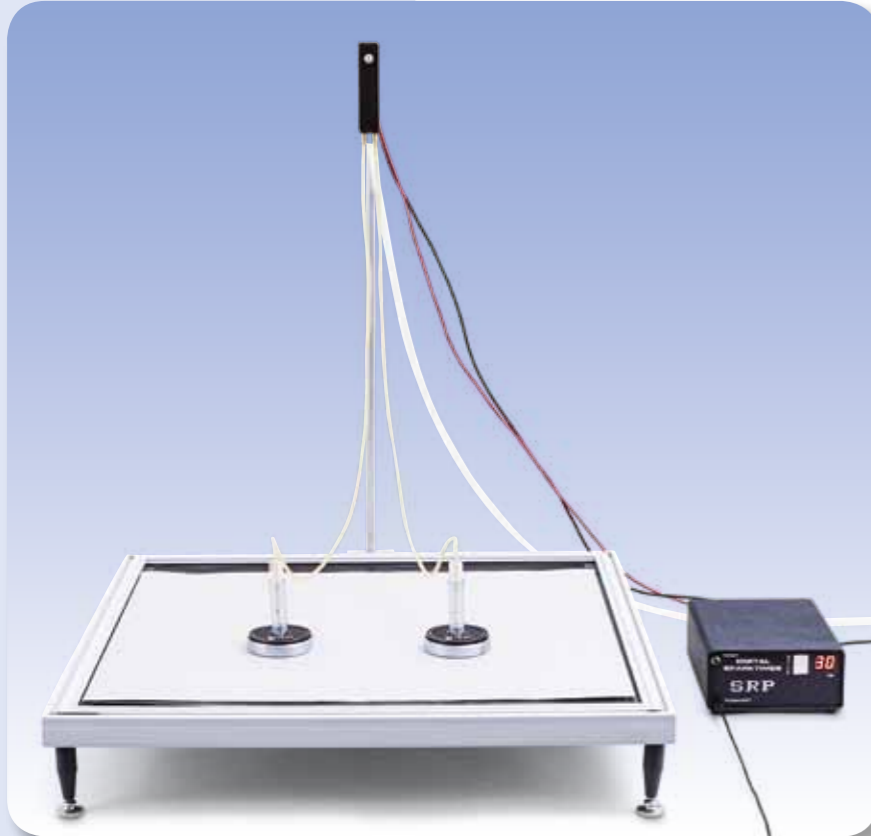

Fig. 1: Flight curves for the smallest initial velocity and different throwing angles, measured experimentally, and calculated theoretically with air friction taken into account

OBJECTIVE

Investigate elastic and inelastic collisions between two objects on a plane

SUMMARY

In any collision between two bodies, the colliding objects must obey the laws of conservation of energy and conservation of momentum. With the help of these two conserved quantities it is possible to describe how the bodies will behave after the collision. In the case of a flat plane, the velocity and momentum need to be expressed as vectors. A particularly simple description can be obtained by switching to a system which focuses on the mutual centre of gravity of the two bodies. In this experiment, two discs of specific mass are allowed to collide on an air cushion table and the velocities are then recorded with the aid of a spark generator.

EXPERIMENT PROCEDURE

- Determine the velocities before and after a collision.
- Verify the conservation of momentum for elastic and inelastic collisions.
- Verify the conservation of energy for elastic and inelastic collisions.
- Investigate the motion of the centres of gravity in the system.

REQUIRED APPARATUS

Quantity	Description	Number
1	Air Cushion Table (230 V, 50/60 Hz)	1013210 or
	Air Cushion Table (115 V, 50/60 Hz)	1012569
1	Pair of Magnetic Pucks	1003364
Additionally recommended		
1	Mechanical Balance 610	1003419
1	Ruler, 50 cm	
1	Goniometer	

BASIC PRINCIPLES

A collision refers to a brief interaction between two bodies. It is assumed that this interaction takes place in the space of a certain, short length of time and that the bodies do not affect one another in any other way. If no other forces are present, the two bodies will move at constant velocities both before and after the collision. Since the two bodies may be regarded as a closed system, the interaction must obey the laws of conservation of momentum and conservation of energy.

The velocities of bodies 1 and 2 before the collision are represented by the vectors v_1 and v_2 . Those after the collision are represented by v'_1 and v'_2 . The corresponding momentum is represented by p_i and p'_i ($i = 1, 2$). The masses of both bodies remain constant over time and are labelled m_1 and m_2 . Due to conservation of momentum, the following must be true:

$$(1) \quad m_1 \cdot v_1 + m_2 \cdot v_2 = m_1 \cdot v'_1 + m_2 \cdot v'_2$$

In addition, when the collisions are elastic, the overall kinetic energy in the system is also conserved:

$$(2) \quad \frac{1}{2} \cdot m_1 \cdot v_1^2 + \frac{1}{2} \cdot m_2 \cdot v_2^2 = \frac{1}{2} \cdot m_1 \cdot v'^2_1 + \frac{1}{2} \cdot m_2 \cdot v'^2_2$$

If body 2 is at rest before the collision, it is possible to select a coordinate system in which the motion of body 1 is along the x-axis ($v_{1y} = 0$). This does not in any way affect the generality of the description.

First let us consider a collision in line with the centres of gravity of both objects, where $d = 0$, see Fig. 1. The bodies will then move along the x-axis and the velocities after the collision are given by:

$$(3) \quad v'_1 = \frac{m_1 - m_2}{m_1 + m_2} \cdot v_1$$

and

$$(4) \quad v'_2 = \frac{2m_1}{m_1 + m_2} \cdot v_1$$

For identical masses, $m_1 = m_2$, the following conditions are true:

$$(5) \quad v'_1 = 0$$

and

$$(6) \quad v'_2 = v_1$$

If collisions are off-centre but the masses are the same, the bodies will separate from one another at an angle of 90° , i.e.

$$(7) \quad \theta_1 + \theta_2 = 90^\circ$$

Additionally, if $v_{1y} = 0$ and $m_1 = m_2$, then equation (1) provides the following result:

$$(8) \quad v'_{1y} = -v'_{2y}$$

The position vector for the centre of gravity is as follows:

$$(9) \quad r_s = \frac{m_1 \cdot r_1 + m_2 \cdot r_2}{m_1 + m_2}$$

Since the total momentum is conserved, the velocity of the centre of gravity is constant and is given by the following equation:

$$(10) \quad v_s = \frac{m_1 \cdot v_1 + m_2 \cdot v_2}{m_1 + m_2}$$

The total momentum corresponds to the momentum of a single mass $m_s = m_1 + m_2$, which moves at the same velocity as the centre of gravity. It often makes sense to transform the frame of reference to a system centred on the combined centre of gravity of the two bodies. Then, before the collision, the two bodies will converge towards one another in such a way that the overall momentum is zero. After an elastic collision, they then separate in such a way that the total momentum continues to be zero. After a completely inelastic collision, they stick together and rotate about their mutual centre of gravity. The kinetic energy of the system is also conserved in this case. In this experiment, two discs of known mass are allowed to collide on a cushion of air. The motion they undergo is recorded with the help of a spark generator.

EVALUATION

Calculation of the kinetic energy indicates that some energy is lost. This is due to the sound made upon collision, the slight deformation of the bodies when they collide, any intrinsic rotation of the discs which has not been taken into account and movement of the hoses feeding the cushion of air.

The magnitude of the velocities can be calculated using the following relationship:

$$v = \Delta \cdot f$$

Δ : Distance between two points,

f : Frequency of spark generator

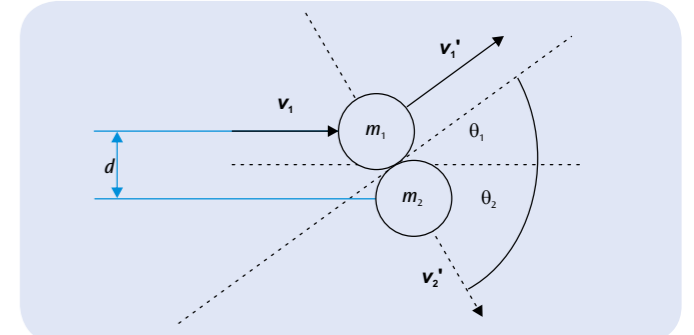

Fig. 1: Schematic representation of an off-centre collision between two bodies

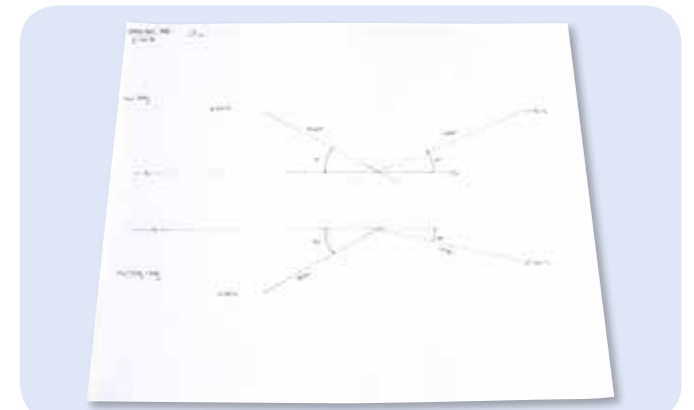

Fig. 2: Recording and evaluation of an off-centre collision between two bodies of unequal mass and initial velocities $v_1 \neq 0$ and $v_2 \neq 0$

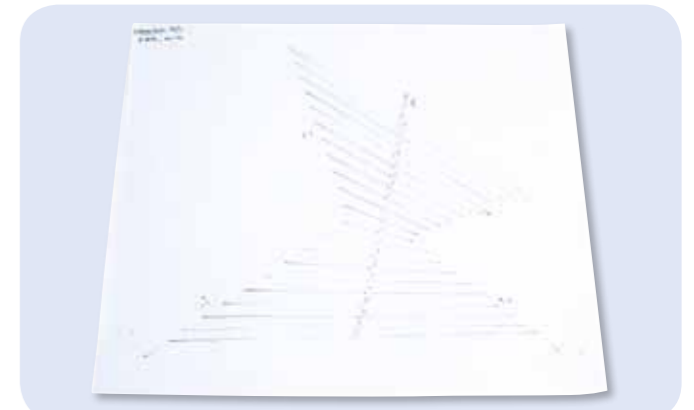

Fig. 3: Position of centre of gravity S

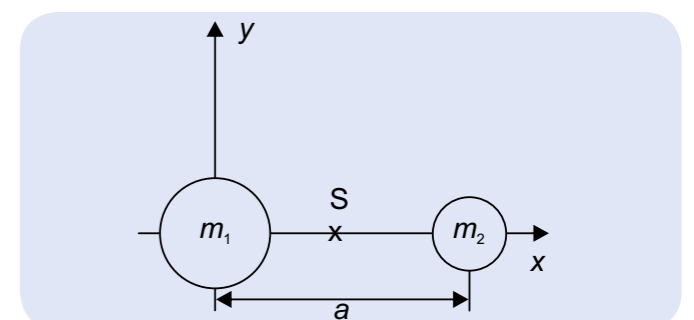

Fig. 4: Motion of centre of gravity S before and after collision

OBJECTIVE

Confirm the law of equal areas for central force motions (Kepler's Second Law)

SUMMARY

As an example of motion under the influence of a central force, the elliptical motion of a pendulum bob is recorded by the dust-marking method. This produces a trace with time-interval marks, and from the distances between these one can directly measure the velocity of the pendulum bob. Furthermore, it can be shown by a simple graphical analysis that the area swept by the radius vector of the pendulum in each time interval is constant, and is thus independent of the length of the radius vector.

EXPERIMENT PROCEDURE

- Recording the elliptical oscillations of a pendulum by the dust-marking method.
- Comparing the velocities of the pendulum bob at the minimum and maximum distances from its rest position.
- Measuring the areas swept by the radius vector of the pendulum in each time interval at the minimum and maximum distances from the rest position.

REQUIRED APPARATUS

Quantity	Description	Number
1	Equipment Set for Powder Tracing	1000739
1	Pendulum with Plotting Electrode	1000780
2	Tripod Stands 150 mm	1002835
2	Stainless Steel Rods 1000 mm	1002936
1	Stainless Steel Rod 750 mm	1002935
3	Multiclamps	1002830

1
BASIC PRINCIPLES

In the motion of a planet around the sun, the angular momentum remains constant, because the force acting on the planet is always directed towards the centre. From this it can be directly concluded that the planet's orbit must lie in a fixed plane. From it one can also derive Kepler's Second Law, the law of equal areas, which states that the light-beam from the sun to the planet sweeps equal areas in equal time intervals.

The validity of the law of equal areas is not affected by the exact form of the dependence of the central force on the distance from the force centre. This dependence only determines the shape of the orbit around the force centre. Thus, the equal areas law is also valid for the elliptical oscillations of a pendulum around the rest position, provided that the deflection angle from the vertical is not too great. The movement of the pendulum bob is almost exactly confined to a horizontal plane (see Fig. 1), and at any point on its path defined by the radius vector r there is a horizontal restraining force F directed towards the rest position, given by:

$$(1) \quad F = -\frac{m \cdot g}{d} \cdot r$$

g : gravitational acceleration,
 d : length of pendulum,
 m : mass of pendulum bob.

The angular momentum, which is

$$(2) \quad L = m \cdot r(t) \times \frac{\Delta r(t)}{\Delta t}$$

remains unaffected by force F . Therefore, the area ΔA swept by the radius vector $r(t)$ in each time interval Δt also remains constant:

$$(3) \quad \Delta A = \frac{1}{2} |r(t) \times \Delta r(t)| = \frac{1}{2} \cdot r(t) \cdot \Delta r(t) \cdot \sin \alpha$$

(see Fig. 2).

In the experiment the motion of the pendulum bob is recorded by the dust-marking method. In this method, the recording electrode attached to the pendulum bob is allowed to glide above an insulated tracking plate covered with fine sulphur powder. An alternating voltage at the mains frequency is applied between the electrode and the tracking plate, so that the sulphur powder is alternately attracted and repelled according to the changing polarity. This draws a trace consisting of time marks, and from the distances between these one can directly determine the velocity of the pendulum bob.

EVALUATION

At first, plot a graphical representation and determine the centre of the recorded path and the points on the orbit that correspond to the maximum and minimum distances from the centre.

At each of these points on the orbit, it is possible to determine the area swept by the radius vector in 10 cycles of the alternating voltage. For purposes of simplicity, the areas are calculated by treating them approximately as triangles.

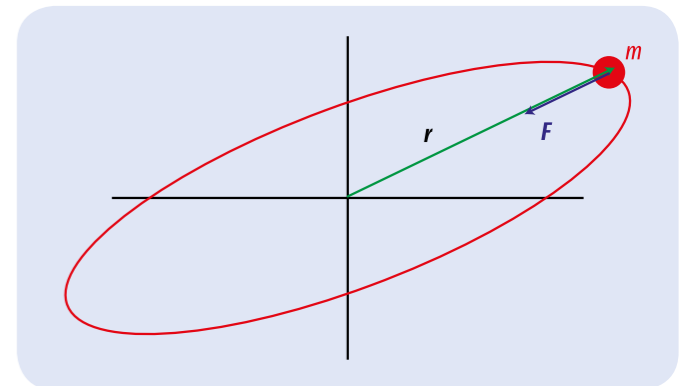

Fig. 1: Elliptical oscillation of the pendulum bob viewed from above

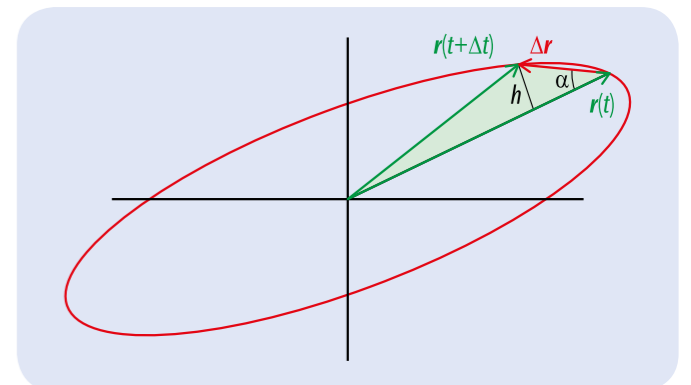
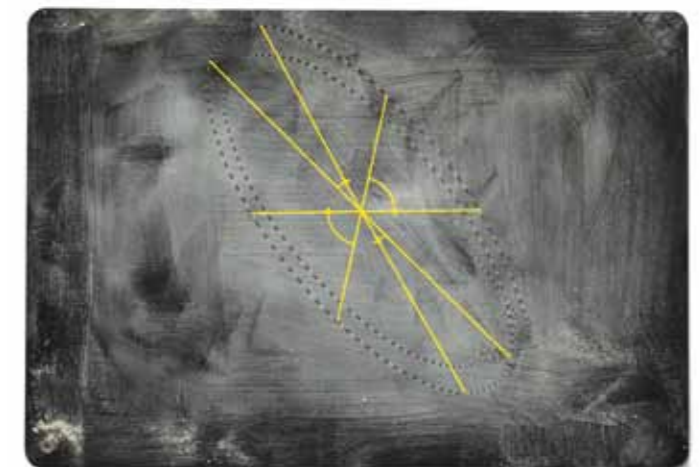

 Fig. 2: The area swept by the radius vector of the pendulum bob in the time interval Δt

Fig. 3: Example of experimentally measured data with calculation



EXPERIMENT PROCEDURE

- Plot the angle of rotation point by point as a function of time for a uniformly accelerated rotational motion.
- Confirm the proportionality between the angle of rotation and the square of the time.
- Determine the angular acceleration as a function of the torque and confirm agreement with Newton's equation of motion.
- Determine the angular acceleration as a function of the moment of inertia and confirm agreement with Newton's equation of motion.

OBJECTIVE

Confirm Newton's equation of motion

SUMMARY

For a body that rotates about a fixed axis with uniform acceleration, the angle of rotation φ increases in proportion to the square of the time t . From this proportionality factor it is possible to calculate the angular acceleration α , which in turn depends, according to Newton's equation of motion, on the accelerating torque (turning moment) and the moment of inertia of the rigid body.

REQUIRED APPARATUS

Quantity	Description	Number
1	Rotating System on Air Bed (230 V, 50/60 Hz)	1000782 or
	Rotating System on Air Bed (115 V, 50/60 Hz)	1000781
1	Laser Reflection Sensor	1001034
1	Digital Counter (230 V, 50/60 Hz)	1001033 or
	Digital Counter (115 V, 50/60 Hz)	1001032

BASIC PRINCIPLES

The rotation of a rigid body about a fixed axis can be described in a way that is analogous to a one-dimensional translational motion. The distance s is replaced by the angle of rotation φ , the linear velocity v by the angular velocity ω , the acceleration a by the angular acceleration α , the accelerating force F by the torque M acting on the rigid body, and the inertial mass m by the rigid body's moment of inertia J about the axis of rotation.



In analogy to Newton's law of motion for translational motion, the relationship between the torque (turning moment) M that is applied to a rigid body with a moment of inertia J , supported so that it can rotate, and the angular acceleration α is:

$$(1) \quad M = J \cdot \alpha$$

If the applied torque is constant, the body undergoes a rotational motion with a constant rate of angular acceleration.

In the experiment, this behaviour is investigated by means of a rotating system that rests on an air-bearing and therefore has very little friction. The motion is started at the time $t_0 = 0$ with zero initial angular velocity $\omega = 0$, and in the time t it rotates through the angle

$$(2) \quad \varphi = \frac{1}{2} \cdot \alpha \cdot t^2$$

The torque M results from the weight of an accelerating mass m_M acting at the distance r_M from the axis of rotation of the body, and is therefore:

$$(3) \quad M = r_M \cdot m_M \cdot g$$

the gravitational acceleration constant.

$$g = 9.81 \frac{\text{m}}{\text{s}^2}$$

If two additional weights of mass m_J are attached to the horizontal rod of the rotating system at the same fixed distance r_J from the axis of rotation, the moment of inertia is increased to:

$$(4) \quad J = J_0 + 2 \cdot m_J \cdot r_J^2$$

J_0 : moment of inertia without additional weights.

A number of weights are provided, both for producing the accelerating force and for increasing the moment of inertia. The distances r_M and r_J can also be varied. Thus, it is possible to investigate how the angular acceleration depends on the torque and the moment of inertia in order to confirm the relationship (1).

EVALUATION

The proportionality of the angle of rotation to the square of the time is demonstrated by measuring the times for the angles of rotation 10° , 40° , 90° , 160° and 250° .

To determine the angular acceleration α as a function of the variables M and J , measure the time $t(90^\circ)$ needed for an angle of rotation of 90° with different values of the variable in both cases. For this special case the angular acceleration is

$$\alpha = \frac{\pi}{t(90^\circ)^2}$$

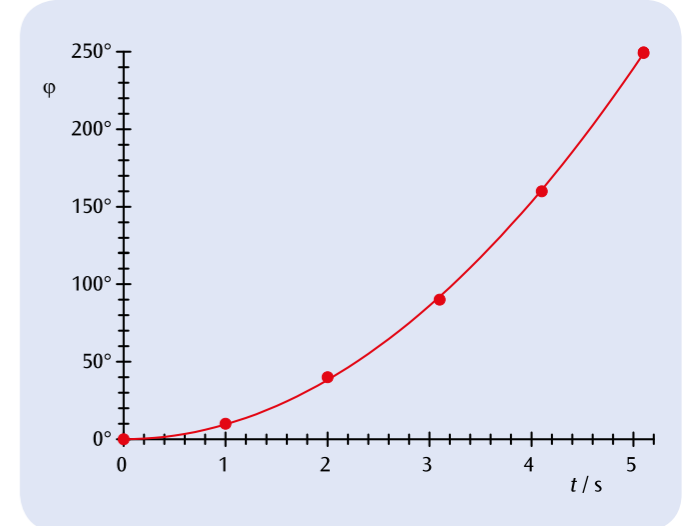

Fig. 1: Angle of rotation as a function of time for a uniformly accelerated rotational motion

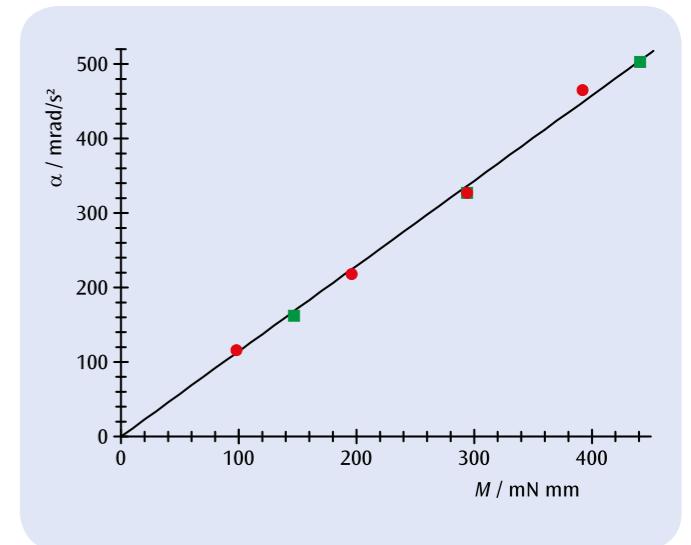

Fig. 2: Angular acceleration α as a function of the torque M

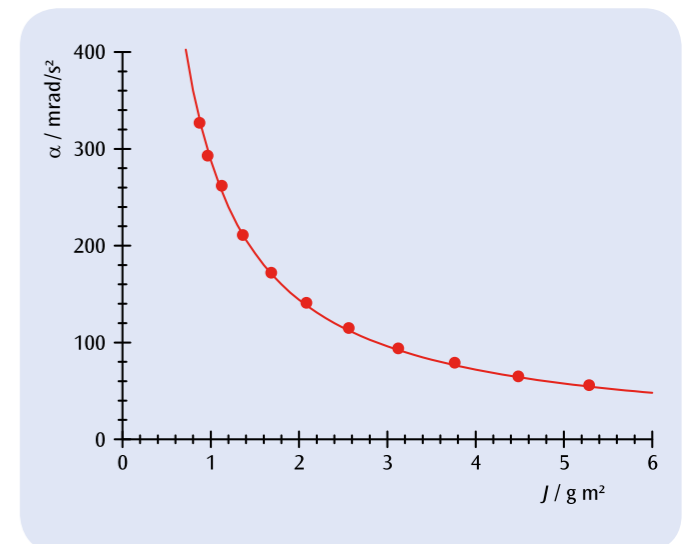

Fig. 3: Angular acceleration α as a function of the moment of inertia J



EXPERIMENT PROCEDURE

- Determine the torsional coefficient D_r of the coupled spring.
- Determine the moment of inertia J as a function of the distance r of the added weights from the axis of rotation.
- Determine the moment of inertia J as a function of the value m of the added weights.

OBJECTIVE

Determine the moment of inertia of a horizontal rod with additional weights attached

SUMMARY

The moment of inertia of a body about its axis of rotation depends on the distribution of its weight in relation to the axis. This is to be investigated for the case of a horizontal rod to which two additional weights are attached symmetrically about the axis of rotation. The rod is coupled to a torsion spring, and its period of oscillation increases as its moment of inertia, which is determined by the additional weights and their distance from the axis, is raised.

REQUIRED APPARATUS

Quantity	Description	Number
1	Rotating System on Air Bed (230 V, 50/60 Hz)	1000782 or
	Rotating System on Air Bed (115 V, 50/60 Hz)	1000781
1	Supplementary Kit for Rotating System on Air Bed	1000783
1	Laser Reflection Sensor	1001034
1	Digital Counter (230 V, 50/60 Hz)	1001033 or
	Digital Counter (115 V, 50/60 Hz)	1001032

1

BASIC PRINCIPLES

The inertia of a rigid body that acts against a change of its rotational motion about a fixed axis is described by the moment of inertia J . It depends on the distribution of weight in relation to the axis of rotation. The greater the distance of a weight from the axis of rotation the greater also is the moment of inertia it causes.

In the experiment, this is investigated using the example of a rotating disc carrying a horizontal rod, to which two additional weights of mass m are attached symmetrically at a distance r from the axis of rotation. For this system the moment of inertia is:

$$(1) \quad J = J_0 + 2 \cdot m \cdot r^2$$

J_0 : moment of inertia without the additional weights.

If the rotating disc is coupled elastically by a coil spring to a rigid stand, the moment of inertia can be determined from the period of torsional oscillation of the disc about its rest position. The relationship is as follows:

$$(2) \quad T = 2\pi \cdot \sqrt{\frac{J}{D_r}}$$

D_r : torsional coefficient of the coil spring.

Thus, the greater the moment of inertia J of the disc with the attached horizontal rod, as dependent on the mass m and the distance r , the longer the period of oscillation T .

EVALUATION

From (2) the following equation is derived to determine the moment of inertia:

$$J = D_r \cdot \frac{T^2}{4\pi^2}$$

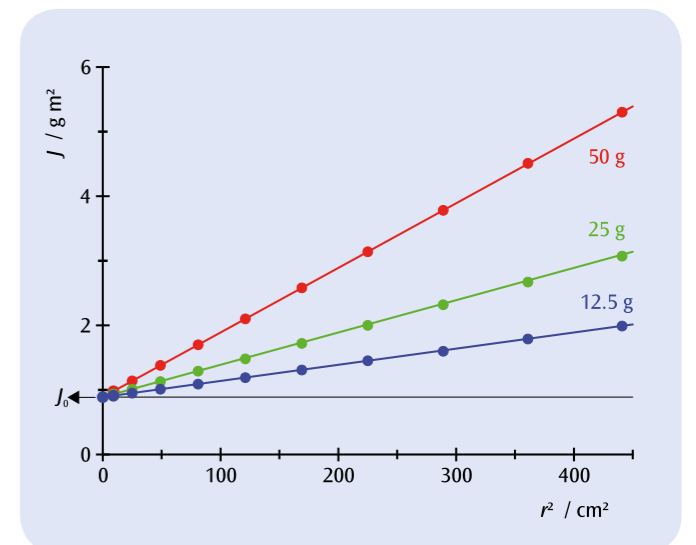

Fig. 1: Moment of inertia J of rotating disc with horizontal rod as a function of the square of the distance r from the axis of rotation for three different additional weights of mass m



EXPERIMENT PROCEDURE

- Determine the torsional coefficient D_r between for the springs used to couple the objects.
- Determine the moment of inertia J for a dumbbell bar without any added weights
- Determine the moment of inertia J as a function of distance r of a weight from its axis of rotation.
- Determine the moment of inertia J for a circular wooden disc, a wooden sphere and both solid and hollow cylinders

OBJECTIVE

Determine the moment of inertia for various test bodies

SUMMARY

A body's moment of inertia around an axis of rotation depends on how the mass of the object is distributed with respect to the axis. This will be investigated for a dumbbell, which has two weights symmetrically aligned either side of the axis, for a circular wooden disc, a wooden sphere and both solid and hollow cylinders. The period of oscillation of the test bodies is dependent on the mass distribution and the effective radius of the object.

REQUIRED APPARATUS

Quantity	Description	Number
1	Torsion Axle	1008662
1	Photo Gate	1000563
1	Digital Counter (230 V, 50/60 Hz)	1001033 or
	Digital Counter (115 V, 50/60 Hz)	1001032
1	Barrel Foot, 1000 g	1002834
1	Tripod Stand 185 mm	1002836
1	Precision Dynamometer 1 N	1003104
1	Set of Test Bodies for Torsion Axle	1008663

1

BASIC PRINCIPLES

The inertia of a rigid body with respect to a change in its rotational motion around a fixed axis is given by its moment of inertia J . This is dependent on the distribution of mass in the body relative to the axis of rotation and increases at greater distance from the axis of rotation itself.

In general, moment of inertia is defined by means of a volume integral:

$$(1) \quad J = \int r_{\perp}^2 \cdot \rho(r) \cdot dV$$

r_{\perp} : component of r perpendicular to the axis of rotation
 $\rho(r)$: Distribution of mass in the body

Using as an example a dumbbell set, which has two weights of mass m symmetrically arranged at a distance r from the axis of rotation, then the moment of inertia is as follows:

$$(2) \quad J = J_0 + 2 \cdot m \cdot r^2$$

J_0 : Moment of inertia of dumbbell bar without weights

Now we can attach various test bodies to a twisting axis so that they can oscillate. If the period of oscillation is T , then the following is true:

$$(3) \quad T = 2\pi \cdot \sqrt{\frac{J}{D_r}}$$

D_r : Torsional coefficient of coil springs

The means that the period of oscillation T will be greater when the moment of inertia J is larger.

The torsional coefficient of the coil springs can be determined with the help of a spring dynamometer:

$$(4) \quad D_r = \frac{F \cdot r}{\alpha}$$

α : Deflection from equilibrium state

EVALUATION

From equation (3) it is possible to obtain a formula for determining the moment of inertia:

$$J = D_r \cdot \frac{T^2}{4\pi^2}$$

For the set-up involving the dumbbell, it is then necessary to subtract the moment of inertia of the bar itself: $J(\text{weights}) = J(\text{bar} + \text{weights}) - J(\text{bar})$.

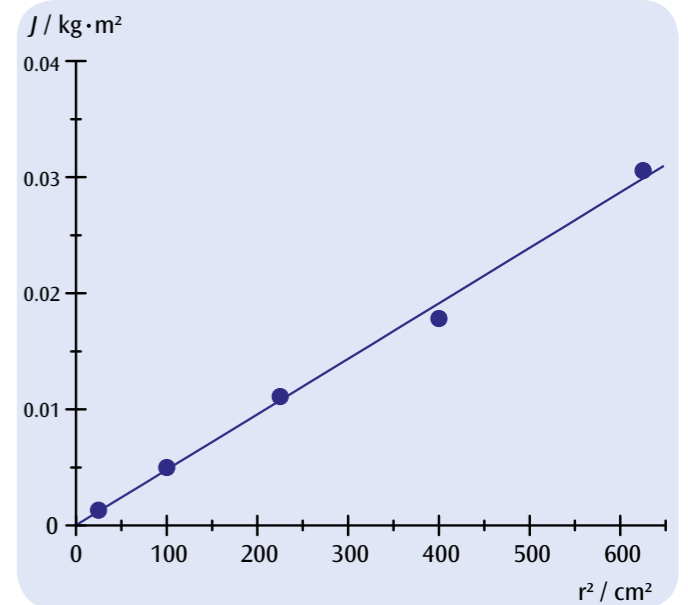

Fig. 1: Moment of inertia J of weights as a function of their radius r from the axis of rotation



EXPERIMENT PROCEDURE

- Verify that the frequency of rotation f_R of a rotating disc is proportional to the period of precession of a gyroscope T_P and determine the moment of inertia by plotting $f_R(T_P)$.
- Verify that the frequency of rotation f_R of a rotating disc is proportional to the frequency of nutation f_N by plotting $f_N(f_R)$ or the corresponding periods $T_R(T_N)$.

OBJECTIVE

Experimental investigation of precession and nutation of a gyroscope and determination of moment of inertia

SUMMARY

A spinning disc exhibits motions known as precession and nutation in addition to its rotational motion, depending on whether there is an external force, and thereby an additional torque, acting upon its axle or if the axle of a disc spinning in an equilibrium state is then deflected from its equilibrium position. The period of precession is inversely proportional to the period of rotation while the period of nutation is directly proportional to the period of rotation. The way the period of precession depends on the period of rotation makes it possible to determine the moment of inertia of the rotating disc.

REQUIRED APPARATUS

Quantity	Description	Number
1	Gyroscope	1000695
2	Photo Gate	1000563
1	Laser Diode, Red	1003201
1	3B NETlog™ (230 V, 50/60 Hz)	1000540 or
	3B NETlog™ (115 V, 50/60 Hz)	1000539
1	3B NETlab™	1000544
3	Tripod Stand 150 mm	1002835
3	Universal Clamp	1002830
3	Stainless Steel Rod 750 mm	1002935

BASIC PRINCIPLES

A spinning top is a rigid body which spins around an axis fixed at a given point. If an external force acts upon the axis, its torque causes a change in the angular momentum. The top then moves in a direction perpendicular to the axis and the force acting upon it. Such a motion is called precession. If a top is pushed away from its axis of rotation it starts to undergo a tipping

motion. This motion is called nutation. In general, both these motions occur superimposed on one another.

In this experiment, a gyroscope is used rather than a top. Its large rotating disc rotates with low friction about an axis which is fixed at a certain bearing point. A counterweight is adjusted in such a way that the bearing point coincides with the centre of gravity. If the gyroscope is in equilibrium and the disc is set spinning, the momentum L will be constant:

$$(1) \quad L = I \cdot \omega_R$$

I : moment of inertia, ω_R : angular velocity

The moment of inertia of the rotating disc of the gyroscope is given by:

$$(2) \quad I = \frac{1}{2} \cdot M \cdot R^2$$

M : mass of disc, R : radius of disc

If extra weight is put on the axis of rotation by addition of a mass m , the additional weight causes a torque τ which changes the angular momentum:

$$(3) \quad \tau = m \cdot g \cdot r = \frac{dL}{dt}$$

r : distance from bearing point of axis of rotation to where the weight of the additional mass acts.

The axis of rotation then moves as shown in Fig. 2 by the following angle:

$$(4) \quad d\varphi = \frac{dL}{L} = \frac{m \cdot g \cdot r \cdot dt}{L}$$

It also starts to precess. The angular velocity of the precession motion can then be derived:

$$(5) \quad \omega_P = \frac{d\varphi}{dt} = \frac{m \cdot g \cdot r}{L} = \frac{m \cdot g \cdot r}{I \cdot \omega_R}$$

where $\omega = 2\pi/T = 2\pi f$:

$$(6) \quad \frac{1}{T_R} = f_R = \frac{m \cdot g \cdot r}{I} \cdot T_P$$

If the disc is set spinning in the absence of any extra external torque and the axis of rotation is slightly deflected to one side, the gyroscope will exhibit nutation. The angular velocity of the nutation is then directly proportional to the angular velocity of the rotation:

$$(7) \quad \omega_N = C \cdot \omega_R \quad \text{and} \quad T_R = C \cdot T_N$$

C : constant

This experiment involves racing the rotational, precessive and nutative motions with the help of photoelectric light barriers, whereby the way the pulses change over time is recorded and displayed by 3B NETlog™ and 3B NETlab™ units.

EVALUATION

The periods of rotation, precession and nutation are determined from the recordings of how the pulses change over time. According to equation (6), the period of precession is inversely proportional to that of the rotation, while (7) says that the period of nutation is directly proportional to that of the rotation. On the respective graphs, the measured values will therefore lie along a straight line through the origin. From the slope of a line matched to these values $f_R(T_P)$ it is possible to obtain the moment of inertia of the gyroscope's rotating disc by experiment and then compare it with the theoretical value calculated using equation (2).

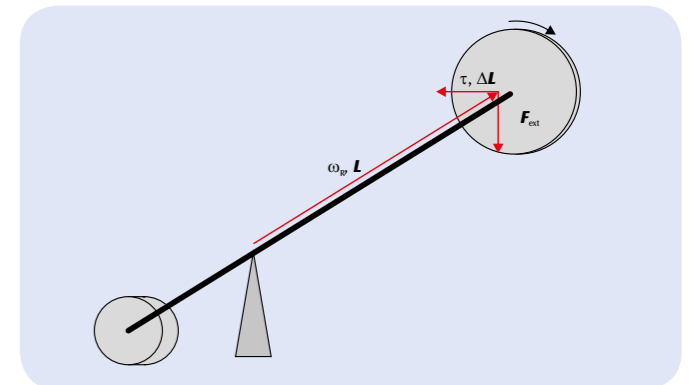

Fig. 1: Schematic of a gyroscope illustrating precession

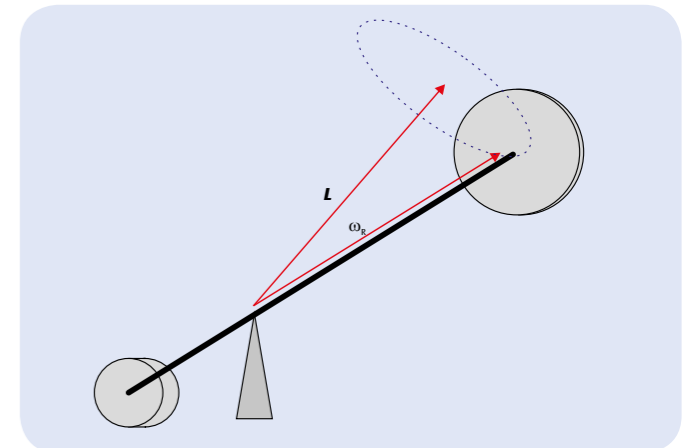

Fig. 2: Schematic of a gyroscope illustrating nutation

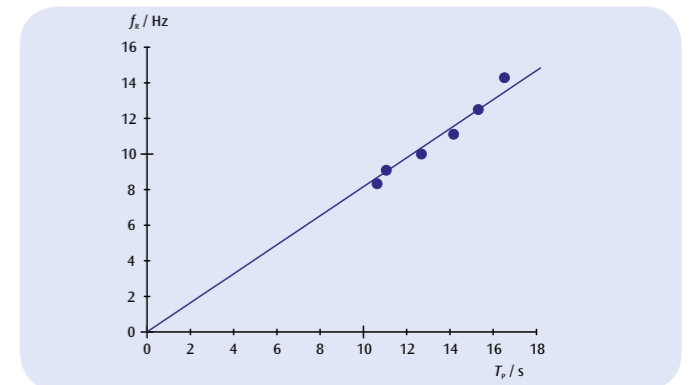

Fig. 3: Frequency of rotation f_R of a rotating disc as a function of the period of precession T_P

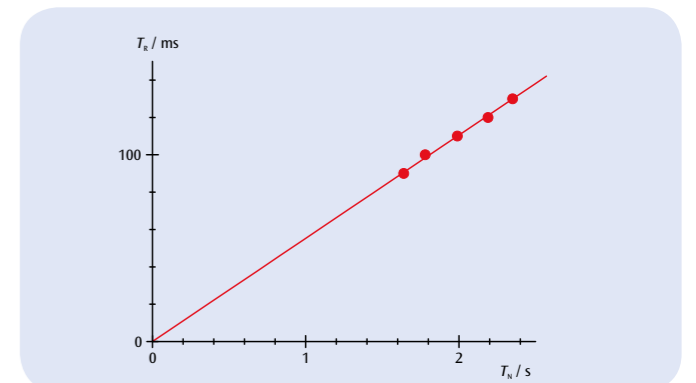
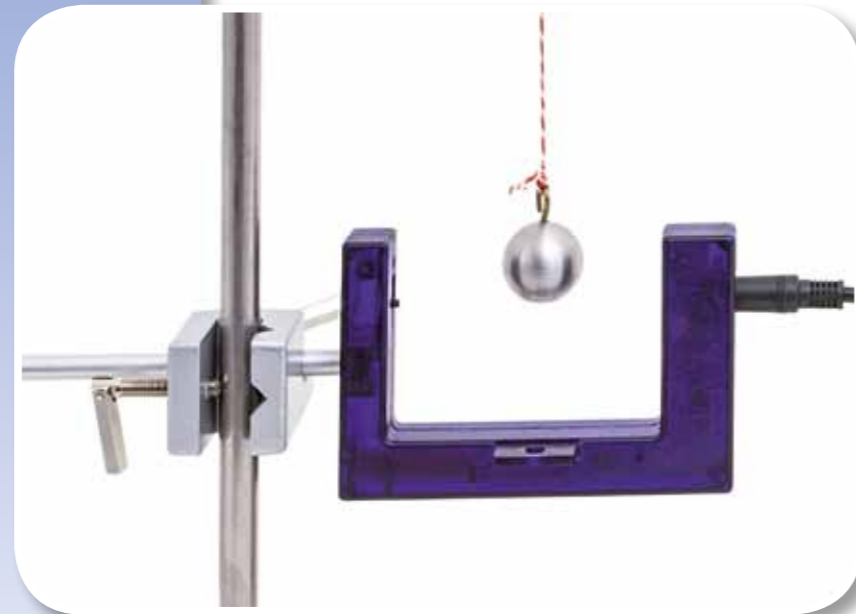

Fig. 4: Period of rotation T_R as a function of period of nutation T_N

OBJECTIVE

Measuring the period of oscillation of a string pendulum with bobs of various masses

EXPERIMENT PROCEDURE

- Measure the period of oscillation T of a string pendulum as a function of the length of the pendulum L .
- Measure the period of oscillation T of a string pendulum as a function of the mass of the pendulum bob m .
- Determine the acceleration due to gravity g .

SUMMARY

The period of oscillation T for a string pendulum is dependent on the length of the pendulum L , but does not depend on the mass of the bob m . This is to be verified by a series of measurements in which the period of oscillation of such a pendulum is measured by means of a photoelectric sensor connected to a digital counter.

REQUIRED APPARATUS

Quantity	Description	Number
1	Set of 4 Pendulum Bobs	1003230
1	Cord for Experiments	1001055
1	Tripod Stand 185 mm	1002836
1	Stainless Steel Rod 1500 mm	1002937
1	Stainless Steel Rod 100 mm	1002932
1	Clamp with Hook	1002828
2	Universal Clamp	1002830
1	Photo Gate	1000563
1	Digital Counter (230 V, 50/60 Hz)	1001033 or
	Digital Counter (115 V, 50/60 Hz)	1001032
1	Pocket Measuring Tape, 2 m	1002603
1	Electronic Scale 200 g	1003433

1
BASIC PRINCIPLES

A string pendulum with a bob of mass m and a length L will exhibit simple harmonic oscillation about its rest point as long as the angle of deflection is not too great. The period T , i.e. the time it takes for the pendulum to swing from one end of its motion to the other end and back, is dependent solely on the length of the pendulum L and not on the mass m .

If the pendulum is deflected from its rest position by an angle φ , the restoring force is as follows:

$$(1a) \quad F_1 = -m \cdot g \cdot \sin \varphi.$$

For small angles φ , this closely approximates to the following:

$$(1b) \quad F_1 = -m \cdot g \cdot \varphi$$

The moment of inertia of the accelerated mass is given by

$$(2) \quad F_2 = m \cdot L \cdot \ddot{\varphi}$$

Both these forces are equal, thus the result is equivalent for the equation of motion for simple harmonic oscillation:

$$(3) \quad \ddot{\varphi} + \frac{g}{L} \cdot \varphi = 0$$

For the period of oscillation T the following applies:

$$(4) \quad T = 2\pi \cdot \sqrt{\frac{L}{g}}$$

In this experiment the period of oscillation will be measured for various lengths of pendulum and masses of bob with the help of a photoelectric sensor connected to a digital counter. The digital counter's internal programming is such that it halts the time measurement after each complete swing of the pendulum.

EVALUATION

The measurements are plotted on a graph of T against L and another one of T against m . These graphs will show that the period of oscillation depends on the pendulum's length and not on the mass of the bob, as expected.

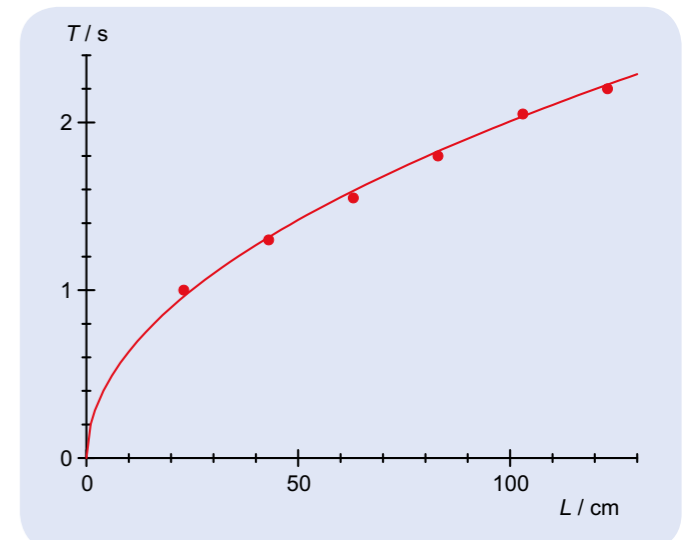
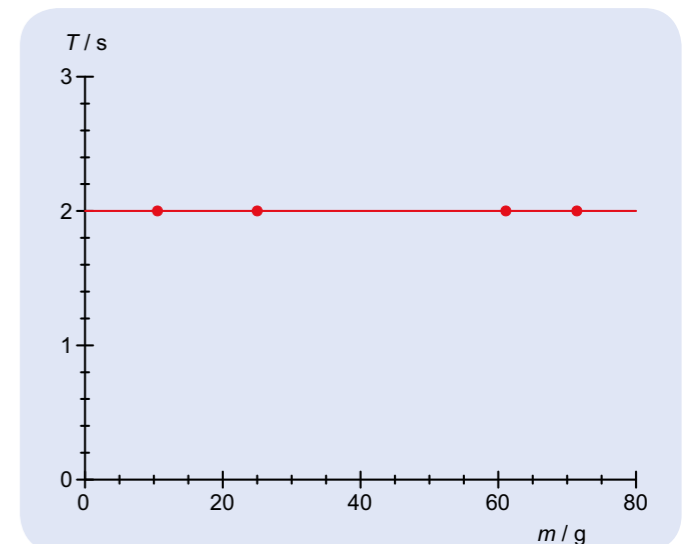
 Fig. 1: Period of oscillation T as a function of the pendulum length L

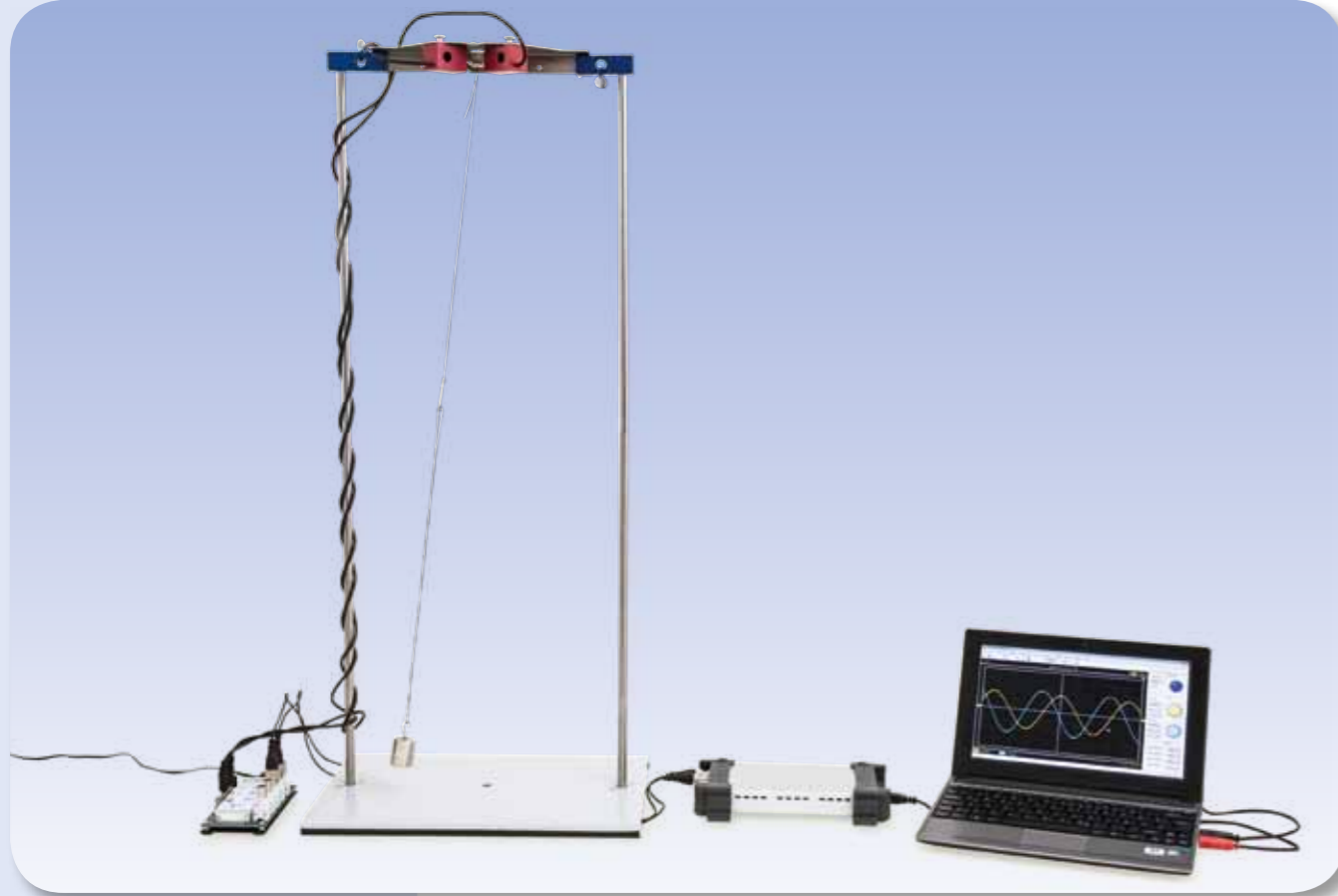
 Fig. 2: Period of oscillation T as a function of the pendulum mass m



EXPERIMENT PROCEDURE

- Plot the elliptical oscillation of a string pendulum in the form of two perpendicular components for a variety of initial conditions.

OBJECTIVE

Description of elliptical oscillations of a string pendulum as the superimposition of two components perpendicular to one another

SUMMARY

Depending on the initial conditions, a suitable suspended string pendulum will oscillate in such a way that the bob's motion describes an ellipse for small pendulum deflections. If the motion is resolved into two perpendicular components, there will be a phase difference between those components. This experiment will investigate the relationship by measuring the oscillations with the help of two perpendicularly mounted dynamic force sensors. The amplitude of the components and their phase difference will then be evaluated.

REQUIRED APPARATUS

Quantity	Description	Number
1	SW String Pendulum Set	1012854
1	SW Stand Equipment Set	1012849
1	SW Sensors Set (230 V, 50/60 Hz)	1012850 or
	SW Sensors Set (115 V, 50/60 Hz)	1012851
1	USB Oscilloscope 2x50 MHz	1017264

1

BASIC PRINCIPLES

Depending on the initial conditions, a suitable suspended string pendulum will oscillate in such a way that the bob's motion describes an ellipse for small pendulum deflections. If the motion is resolved into two perpendicular components, there will be a phase difference between those components.

This experiment will investigate the relationship by measuring the oscillations with the help of two perpendicularly mounted dynamic force sensors. The amplitude of the components and their phase difference will then be evaluated. The phase shift between the oscillations will be shown directly by displaying the oscillations on a dual-channel oscilloscope.

Three special cases shed light on the situation:

- If the pendulum swings along the line bisecting the two force sensors, the phase shift $\varphi = 0^\circ$.
- If the pendulum swings along a line perpendicular to that bisecting the two force sensors, the phase shift $\varphi = 180^\circ$.
- If the pendulum bob moves in a circle, the phase shift $\varphi = 90^\circ$.

EVALUATION

The oscillations are recorded by means of a storage oscilloscope and frozen on screen. The amplitude of the components and their phase difference will then be evaluated.

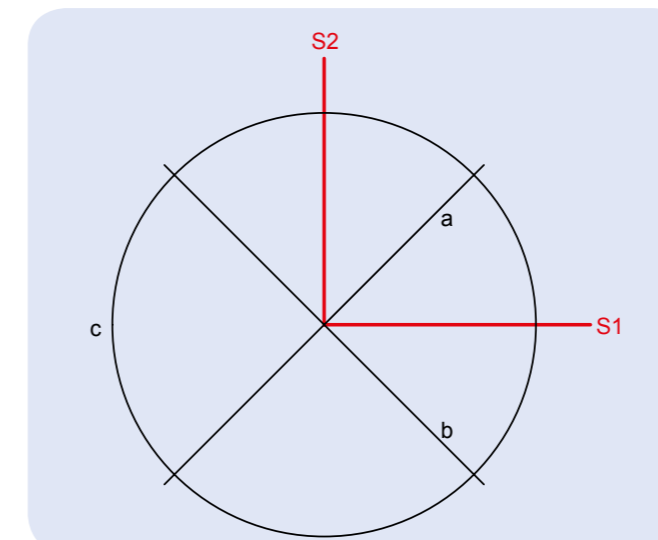

Fig. 1: The alignment of sensors S1 and S2, including the oscillation directions of the string pendulum under investigation

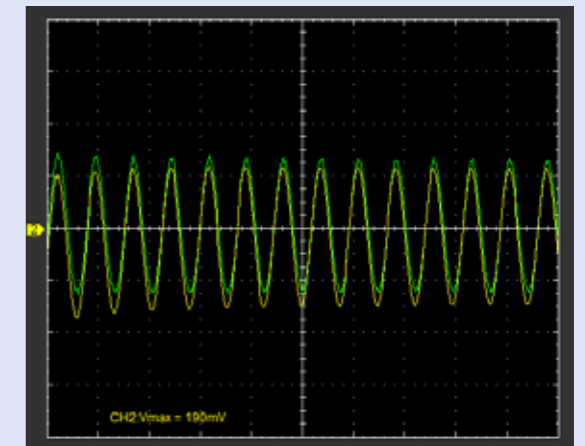

Fig. 2: Oscillation components for a string pendulum swinging along the line bisecting the two force sensors

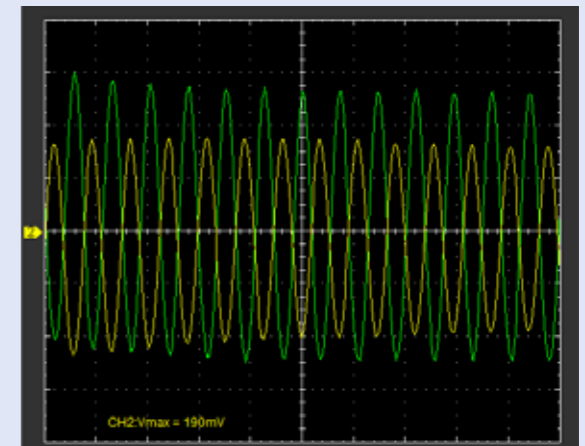

Fig. 3: Oscillation components for a string pendulum swinging along the line perpendicular to that bisecting the two force sensors

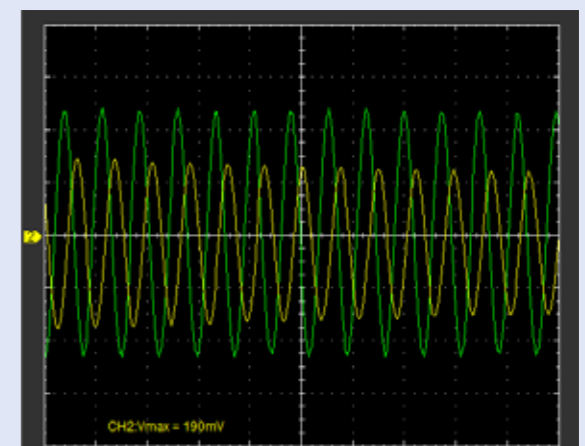

Fig. 4: Oscillation components for a string pendulum describing a circle



EXPERIMENT PROCEDURE

- Measure the period T as a function of the effective component of the gravitational acceleration g_{eff} .
- Measure the period T for various pendulum lengths L .

OBJECTIVE

Measure the period of an oscillating pendulum as a function of the effective component of the gravitational acceleration

SUMMARY

The period of a pendulum is lengthened by tilting its axis away from the horizontal, since the effective component of the gravitational acceleration is reduced.

REQUIRED APPARATUS

Quantity	Description	Number
1	Variable g Pendulum	1000755
1	Support for Photogate	1000756
1	Photo Gate	1000563
1	Digital Counter (230 V, 50/60 Hz)	1001033 or
	Digital Counter (115 V, 50/60 Hz)	1001032
1	Tripod Stand 150 mm	1002835
1	Stainless Steel Rod 470 mm	1002934

2

BASIC PRINCIPLES

The period of a pendulum is determined mathematically by the length of the pendulum L and the acceleration due to gravity g . The effect of the gravitational acceleration can be demonstrated by tilting the axis of the pendulum so that it is no longer horizontal.

When the axis is tilted, the component of the gravitational acceleration g that is parallel to the axis g_{par} is rendered ineffective by the fact that axis is fixed (see Fig.1). The remaining component that is effective g_{eff} is given by the following equation:

$$(1) \quad g_{\text{eff}} = g \cdot \cos \alpha$$

α : is the inclination of the axis to the horizontal

When the pendulum is deflected by an angle φ from its rest position a suspended weight of a mass m experiences a returning force of the following magnitude:

$$(2) \quad F = -m \cdot g_{\text{eff}} \cdot \sin \varphi$$

For small angles the equation of motion of the pendulum comes out as the following:

$$(3) \quad m \cdot L \cdot \ddot{\varphi} + m \cdot g_{\text{eff}} \cdot \varphi = 0$$

The pendulum's angular frequency of oscillation is therefore:

$$(4) \quad \omega = \sqrt{\frac{g_{\text{eff}}}{L}}$$

EVALUATION

Equation (4) implies that the period of the pendulum is as follows:

$$T = 2\pi \sqrt{\frac{L}{g_{\text{eff}}}}$$

Thus, shortening the pendulum causes the period to be shorter and reducing the effective component of the gravitational acceleration makes the period longer.

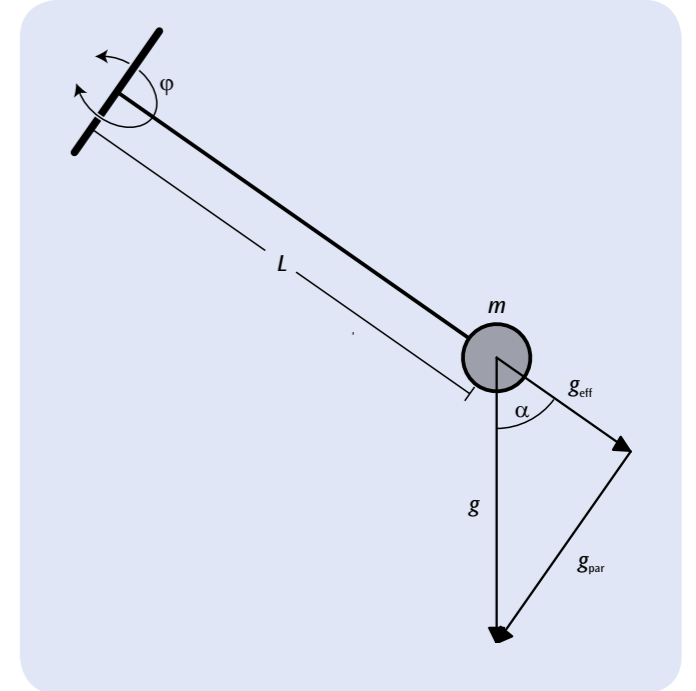

Fig. 1: Variable g pendulum (schematic)

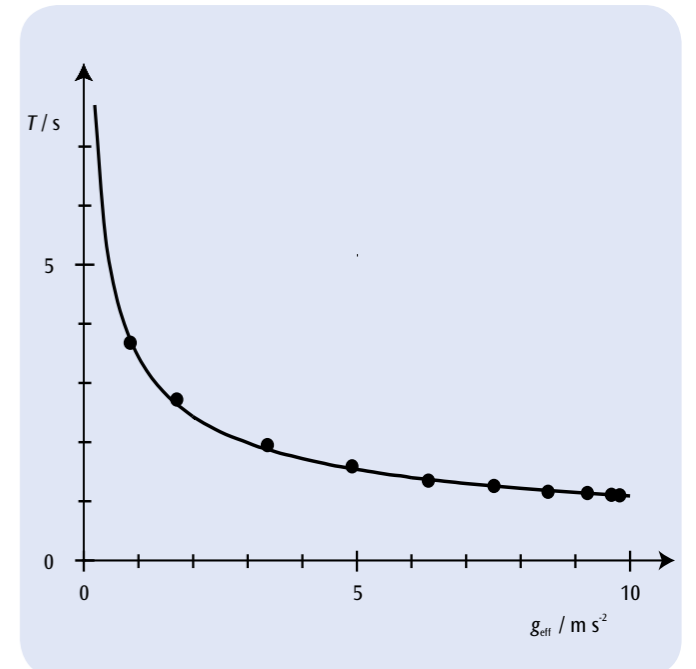

Fig. 2: Period of the pendulum as a function of the effective component of the gravitational acceleration
Line calculated for pendulum length $L = 30 \text{ cm}$

EXPERIMENT PROCEDURE

- Measure the direction of the oscillation as a function of time.
- Determine the speed of the rotation.
- Determine the latitude where the experiment is taking place.

OBJECTIVE

Demonstrate the rotation of the earth with a Foucault pendulum

SUMMARY

A Foucault pendulum is a long string pendulum with a heavy bob, which can be used to demonstrate the rotation of the earth. In this experiment, a pendulum 1.2 metres in length is used. The direction of its oscillations can be very accurately determined by projecting the pendulum's shadow. For long periods of observation, any damping of the oscillation can be compensated for with the aid of an adjustable electromagnetic system to provide additional momentum.



REQUIRED APPARATUS

Quantity	Description	Number
1	Foucault Pendulum (230 V, 50/60 Hz)	1000748 or
	Foucault Pendulum (115 V, 50/60 Hz)	1000747
1	Digital Stopwatch	1002811

2

BASIC PRINCIPLES

A Foucault pendulum is a long string pendulum with a heavy bob, which can be used to demonstrate the rotation of the earth. It is named after Jean Foucault, who in 1851 discovered that the direction of the oscillation of a pendulum 2 m in length would change over the course of time. This experiment was later repeated with ever longer and heavier pendulums.

Since the earth rotates on its axis, when using an earth-based coordinate system, a force called the Coriolis force arises, which then acts on the moving pendulum in a direction perpendicular to the direction of the oscillation:

$$(1) \quad F = 2 \cdot m \cdot \Omega_0 \times v$$

m : mass of pendulum bob
 Ω_0 : vector describing angular velocity of earth
 v : velocity vector of oscillating pendulum

This causes the plane of the oscillation to turn with an angular frequency dependent on the angle of latitude φ of the point from which the pendulum is suspended:

Because the Foucault pendulum is only deflected by a small angle α , the pendulum bob can be assumed to move exclusively in the horizontal plane, which can be seen in Fig. 1, and moves between an axis N aligned with north and an axis E aligned with east. The observation is concerned only with horizontal deflections since the pendulum bob is hanging from a thread. For this reason, only the vertical component of the vector Ω_0 is relevant:

$$(2) \quad \Omega(\varphi) = \Omega_0 \cdot \sin\varphi$$

The equation of motion for an oscillating Foucault pendulum is therefore as follows:

$$(3) \quad \frac{d^2\alpha}{dt^2} \cdot e_p + 2 \cdot \Omega_0 \cdot \sin\varphi \cdot \frac{d\alpha}{dt} \cdot e_v + \frac{g}{L} \cdot \alpha \cdot e_p = 0$$

L : length of pendulum, g : acceleration due to gravity

e_p : horizontal unit vector parallel to the current direction of oscillation

e_v : horizontal unit vector perpendicular to current direction of oscillation

The solution to this can be separated into a solution for the angle of deflection α and a solution for the turning unit vector e_p parallel to the current direction of oscillation:

$$(4a) \quad \alpha(t) = \cos(\omega \cdot t + \beta) \quad \text{where } \omega = \sqrt{\frac{g}{L}}$$

$$(4b) \quad e_p(t) = e_E \cdot \cos(\psi(t)) + e_N \cdot \sin(\psi(t))$$

where $\psi(t) = \Omega_0 \cdot \sin\varphi \cdot t + \psi_0$: direction of oscillation
 e_E : horizontal unit vector aligned with east
 e_N : horizontal unit vector aligned with north

The plane of the oscillation therefore rotates over the course of time with a frequency as given by equation (2). In the northern hemisphere the rotation is clockwise and in the southern hemisphere it is anti-clockwise. The speed of the rotation is at its highest at the poles, whereas at the equator there is no rotation at all.

In this experiment, a pendulum 1.2 metres in length is used. In order to avoid the oscillations becoming elliptical, the pendulum thread is allowed

to collide with a so-called Charon ring every time it swings. The direction of oscillation can be seen by projecting the shadow of the thread onto an angle scale whereby the angle can be read off with great accuracy. It is possible to observe the rotation of the plane of oscillation after only a few minutes. For long periods of observation, any damping of the oscillation can be compensated for with the aid of an adjustable electromagnetic system to provide additional momentum.

EVALUATION

The angle of the oscillation plane ψ is in linear proportion to the time, see Fig. 2. The value we are seeking $\Omega(\varphi)$ is the gradient of the straight lines through the measurements.

The latitude in degrees can be calculated by rearranging equation (2):

$$\varphi = \frac{180^\circ}{\pi} \cdot \arcsin\left(\frac{86400 \text{ s}}{360 \text{ grd}} \cdot \Omega(\varphi)\right)$$

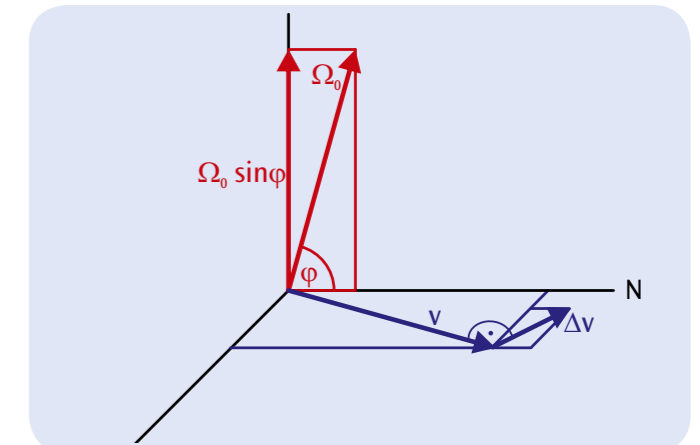

Fig. 1: Illustration of Foucault pendulum in fixed earth-based coordinate system

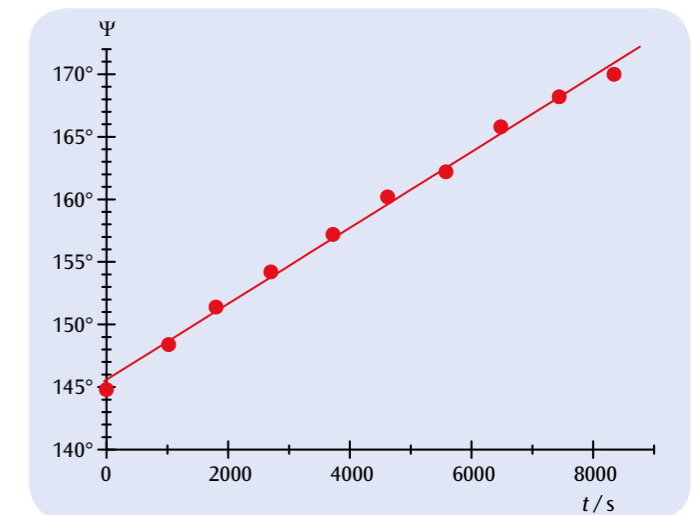
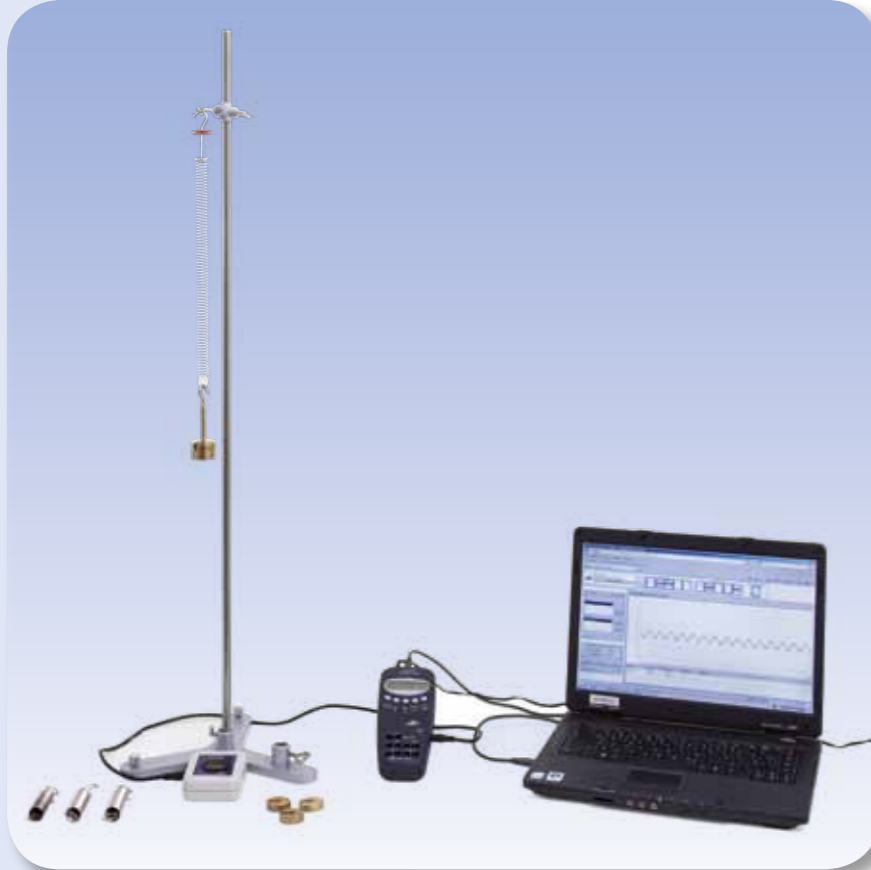

Fig. 2: Measured curve recorded at latitude $\varphi = 50^\circ$

**OBJECTIVE**

Measure the oscillations of a coil spring pendulum using an ultrasonic motion sensor

SUMMARY

The oscillations of a coil spring pendulum are a classic example of simple harmonic oscillation. In this experiment, those oscillations are recorded by an ultrasonic motion sensor, which detects the distance to the weight suspended from the spring pendulum.

EXPERIMENT PROCEDURE

- Record the harmonic oscillation of a coil spring pendulum as a function of time using an ultrasonic motion sensor.
- Determine the period of oscillation T for various combinations of spring constant k and mass m .

REQUIRED APPARATUS

Quantity	Description	Number
1	Set of Helical Springs for Hooke's Law	1003376
1	Set of Slotted Weights, 10 x 10 g	1003227
1	Set of Slotted Weights, 5 x 100 g	1003229
1	Tripod Stand 150 mm	1002835
1	Stainless Steel Rod 1000 mm	1002936
1	Clamp with Hook	1002828
1	Ultrasonic Motion Sensor	1000559
1	3B NET/ab™	1000544
1	3B NET/log™ (230 V, 50/60 Hz)	1000540 or
	3B NET/log™ (115 V, 50/60 Hz)	1000539
1	Pocket Measuring Tape, 2 m	1002603

BASIC PRINCIPLES

Oscillations occur when a system disturbed from its equilibrium position is affected by a force which acts to restore it to equilibrium. This is known as simple harmonic oscillation if the restoring force is proportional to the deviation from the equilibrium position at all times. The oscillations of a coil spring pendulum are one classic example of this. The proportionality between the deviation and the restoring force is described by Hooke's law.

1

The law states that the relationship between the deviation x and the restoring force F is given by

$$(1) \quad F = -k \cdot x$$

where k = spring constant

For a weight of mass m suspended from the spring, the following therefore holds:

$$(2) \quad m \cdot \frac{d^2x}{dt^2} + k \cdot x = 0,$$

This applies as long as the mass of the spring itself and any friction that might arise can be neglected.

In general, solutions to this equation of motion take the following form:

$$(3) \quad x(t) = A \cdot \sin\left(\sqrt{\frac{k}{m}} \cdot t + \varphi\right),$$

This will be verified by experiment by recording the harmonic oscillations of a coil spring pendulum as a function of time with the help of an ultrasonic motion sensor and matching the measured data to a sine function.

The ultrasonic motion sensor detects the distance between itself and the weight suspended from the spring. Other than an offset for the zero point, which can be compensated for by calibration, the measurement corresponds directly to the variable $x(t)$ included in equation 3.

The period of oscillation T is defined as the interval between two points where a sine wave crosses the zero axis in the same direction. From equation (3) it can therefore be seen to be equal to:

$$(4) \quad T = 2\pi \cdot \sqrt{\frac{m}{k}}$$

In order to verify equation (4), the measurements are made for various combinations of mass m and spring constant k , whereby the period of oscillation is determined from where a curve matching the data crosses the zero axis.

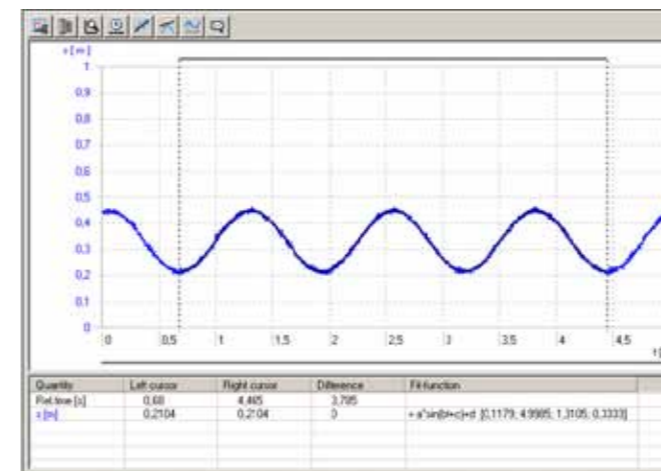

Fig. 1: Recorded oscillation data after matching to a sine function

EVALUATION

The following can be deduced from equation 4:

$$T^2 = \frac{4\pi^2}{k} \cdot m$$

Measurements are therefore plotted using various spring constants k as parameters in a graph of T^2 against m . Within measurement tolerances, they lie on a straight line through the origin, the gradient of which can be calculated using a second graph

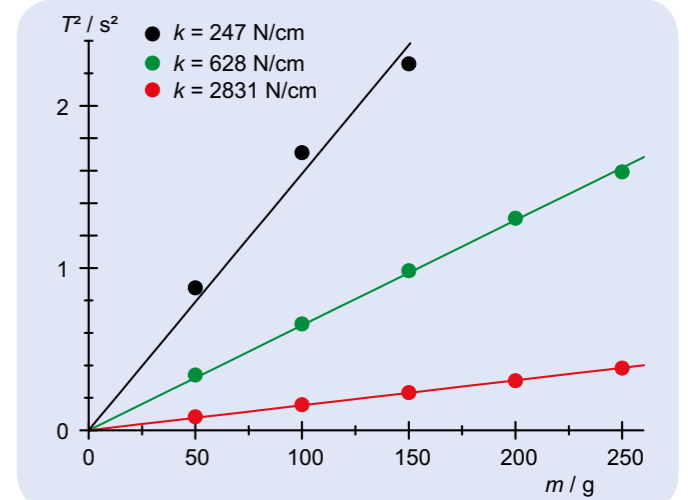

Fig. 2: T^2 as a function of m

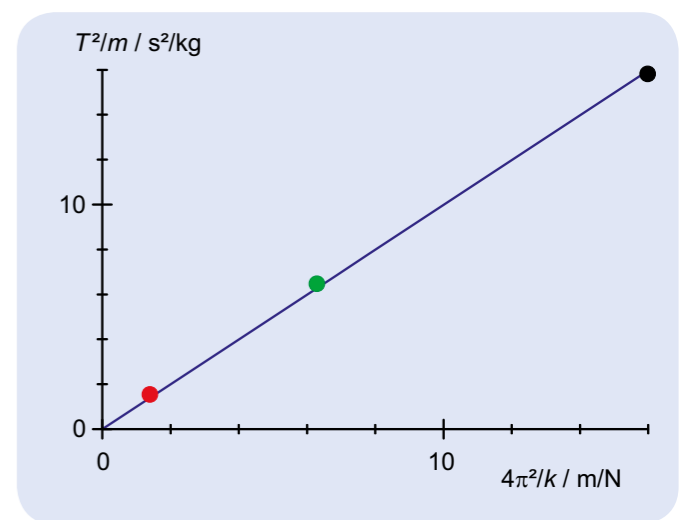
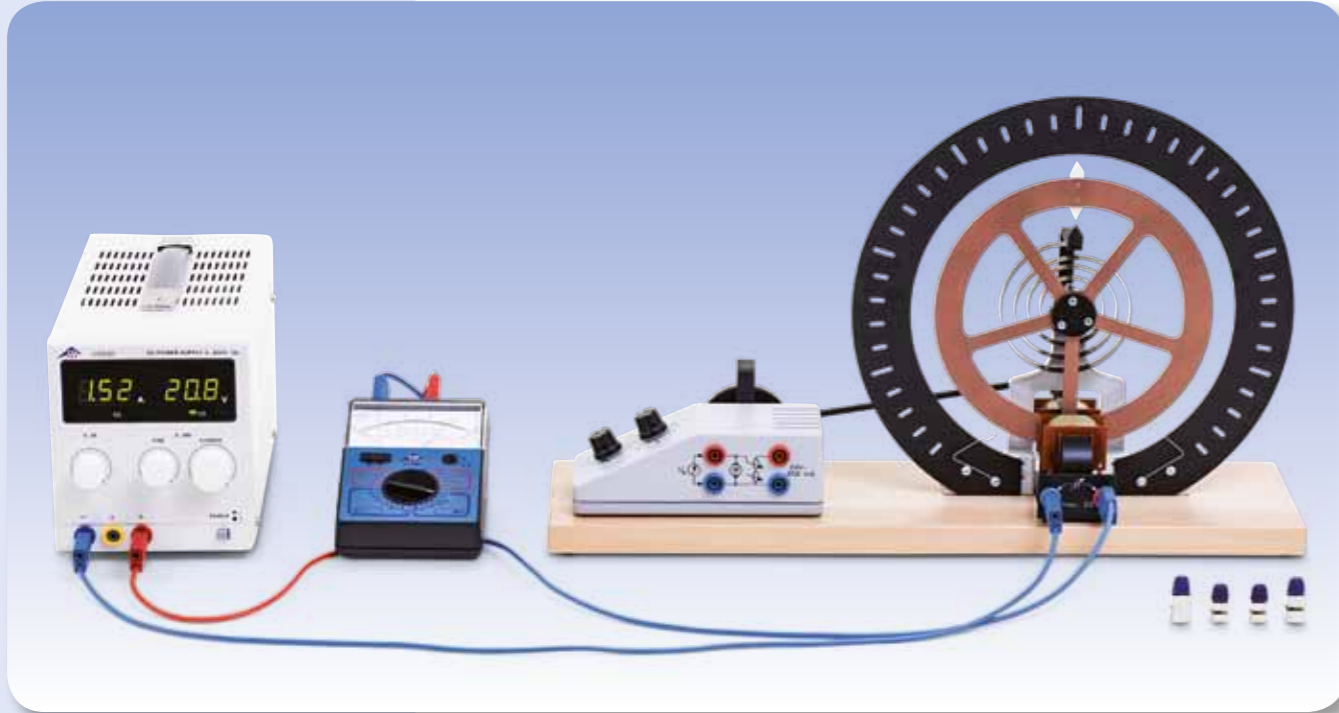

Fig. 3: $\frac{T^2}{m}$ as a function of $\frac{4\pi^2}{k}$



EXPERIMENT PROCEDURE

- Measure period of oscillation T for various initial deflections and velocities.
- Determine the damping constant δ when the rotating pendulum is damped.

OBJECTIVE

Measurement and analysis of simple harmonic rotary oscillation

SUMMARY

Pohl's wheel or rotating (torsional) pendulum allows for the investigation of simple harmonic rotary oscillation. The only forces acting on the wheel are the restoring torque provided by a spiral spring and damping torque supplied by means of an eddy current brake with an adjustable current. This experiment demonstrates how the period of oscillation is not dependent on the initial deflection or the initial velocity, and analyses the amplitudes of the oscillations.

REQUIRED APPARATUS

Quantity	Description	Number
1	Pohl's Torsion Pendulum	1002956
1	Mechanical Stopwatch, 15 min	1003369
1	DC Power Supply 0 – 20 V, 0 – 5 A (230 V, 50/60 Hz)	1003312 or
	DC Power Supply 0 – 20 V, 0 – 5 A (115 V, 50/60 Hz)	1003311
1	Analogue Multimeter AM50	1003073
1	Set of 15 Safety Experiment Leads, 75 cm	1002843

1

BASIC PRINCIPLES

Pohl's wheel or rotating (torsional) pendulum allows for the investigation of simple harmonic rotary oscillation. The only forces acting on the wheel are the restoring torque provided by a spiral spring and damping torque supplied by means of an eddy current brake with an adjustable current.

The equation of motion for the angle of deflection φ of a freely oscillating, but damped torsional pendulum is as follows:

$$(1) \quad \frac{d^2\varphi}{dt^2} + 2 \cdot \delta \cdot \frac{d\varphi}{dt} + \omega_0^2 \cdot \varphi = 0$$

where $\delta = \frac{k}{2J}$ $\omega_0^2 = \frac{D}{J}$

J : moment of inertia
 D : spring constant
 k : damping coefficient

As long as the damping is not excessive and the condition $\delta < \omega_0$ is fulfilled, the equation of motion has the following solution:

$$(2) \quad \varphi(t) = \varphi_0 \cdot e^{-\delta t} \cdot \cos(\omega \cdot t + \psi)$$

where $\omega = \sqrt{\omega_0^2 - \delta^2}$

The initial amplitude φ_0 and the phase angle ψ are arbitrary parameters which are dependent on the deflection and speed of the rotary pendulum at a time $t = 0$. The pendulum will therefore move back and forth with the following period of oscillation:

$$(3) \quad T = \frac{2\pi}{\omega}$$

The amplitude of the oscillations decreases over time according to the following equation:

$$(4) \quad \hat{\varphi}(t) = \varphi_0 \cdot e^{-\delta t}$$

In this experiment oscillations are investigated with various levels of damping, which can be set up by varying the current to the eddy current brake. The period of oscillation is measured with the aid of a stopwatch. It will be shown that the period of oscillation is not dependent on the initial deflection or velocity.

In order to determine the degree of damping the limits of each oscillation to the left and right are taken down. This simplifies the analysis since if such points are taken as the time zero, then the initial velocity will be zero.

EVALUATION

In equation (4) the amplitude of the oscillation is defined as a positive value. This implies that the absolute values for the limits of the motion to the left and right should be considered. If the natural logarithms of these values are plotted against time, a straight line with a gradient $-\delta$ should be obtained. In fact certain deviations from such linear behaviour will be observed, since the force of friction is not exactly proportional to the speed as assumed here.

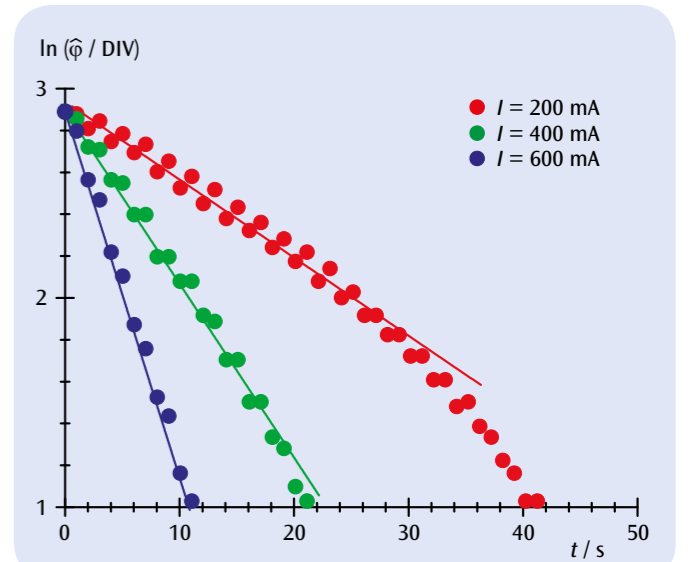
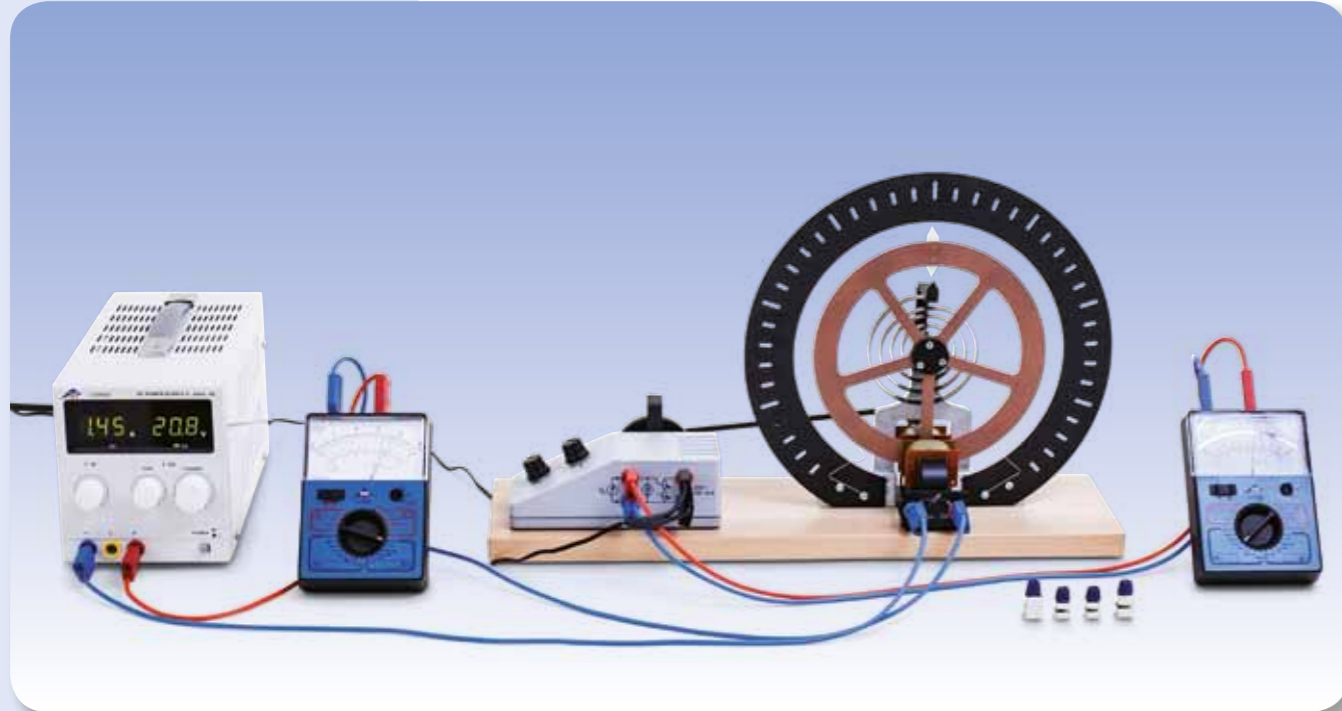

Fig. 1: $\ln(\hat{\varphi})$ as a function of time for various degrees of damping



EXPERIMENT PROCEDURE

- Measure the amplitude of forced oscillations as a function of the excitation frequency for various degrees of damping.
- Observe the phase shift between the excitation and the actual oscillation for excitation frequencies which are very small and other which are very large.

OBJECTIVE

Measurement and analysis of forced harmonic rotary oscillation

SUMMARY

Pohl's wheel or rotating (torsional) pendulum allows for the investigation of forced harmonic rotary oscillation. For this purpose, the oscillating system is connected to an excitation linkage which is driven by an adjustable-speed DC motor so that the restoring spring periodically extends and compresses. In this experiment the amplitude is measured as a function of the excitation frequency for various degrees of damping and the phase shift between the excitation and the actual oscillation is observed.

REQUIRED APPARATUS

Quantity	Description	Number
1	Pohl's Torsion Pendulum	1002956
1	Mechanical Stopwatch, 15 min	1003369
1	Plug In Power Supply 24 V, 0.7 A (230 V, 50/60 Hz)	1000681 or
	Plug In Power Supply 24 V, 0.7 A (115V, 50/60 Hz)	1000680
1	DC Power Supply 0 – 20 V, 0 – 5 A (230 V, 50/60 Hz)	1003312 or
	DC Power Supply 0 – 20 V, 0 – 5 A (115 V, 50/60 Hz)	1003311
2	Analogue Multimeter AM50	1003073
1	Set of 15 Safety Experiment Leads, 75 cm	1002843

2

BASIC PRINCIPLES

Pohl's wheel or rotating (torsional) pendulum allows for the investigation of forced harmonic rotary oscillation. For this purpose, the oscillating system is connected to an excitation linkage which is driven by an adjustable-speed DC motor so that the restoring spring periodically extends and compresses.

The equation of motion for this system is as follows

$$(1) \quad \frac{d^2\varphi}{dt^2} + 2 \cdot \delta \cdot \frac{d\varphi}{dt} + \omega_0^2 \cdot \varphi = A \cdot \cos(\omega_E \cdot t)$$

$$\text{where} \quad \delta = \frac{k}{2J}, \quad \omega_0^2 = \frac{D}{J}, \quad A = \frac{M_0}{J}$$

J : moment of inertia

D : spring constant

k : damping coefficient

M_0 : amplitude of external torque

ω_E : angular frequency of external torque

The solution to this equation is composed of a uniform and a non-uniform component. The uniform component is equivalent to damped simple harmonic motion, as investigated in experiment UE1050500. This decreases exponentially over time and can be neglected by comparison with the non-uniform component after a short period of settling.

The non-uniform component

$$(2) \quad \varphi(t) = \varphi_E \cdot \cos(\omega_E \cdot t - \psi_E)$$

is linked to the external torque, however, and remains non-negligible as long as that torque is present: Its amplitude is as follows:

$$(3) \quad \varphi_E = \frac{A_0}{\sqrt{(\omega_0^2 - \omega_E^2)^2 + 4 \cdot \delta^2 \cdot \omega_E^2}}$$

This becomes increasingly high the closer the excitation frequency ω_E is to the intrinsic resonant frequency ω_0 of the rotating pendulum. Resonance is said to occur when $\omega_E = \omega_0$.

The phase shift is shown below:

$$(4) \quad \psi_E = \arctan\left(\frac{2 \cdot \delta \cdot \omega_E}{\omega_0^2 - \omega_E^2}\right)$$

This indicates that the deflection of the pendulum lags behind the excitation. For low frequencies it is close to zero but as the frequency increases, it rises, reaching 90° at the resonant frequency. For very high excitation frequencies, the excitation and oscillation frequencies end up being 180° out of phase.

EVALUATION

The amplitudes of the damped oscillations are plotted against the excitation frequency. This results in a selection of curves which can be described by equation (4) as long as the appropriate damping parameter δ is chosen.

There will be slight deviations from the damping values measured in experiment UE1050500. This is mainly due to the fact that the force of friction is not exactly proportional to the speed as assumed here.

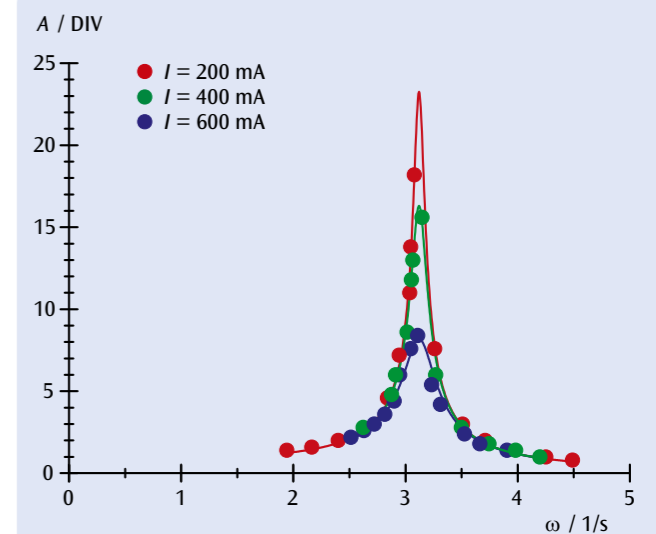

Fig. 1: Resonance curves for various degrees of damping



EXPERIMENT PROCEDURE

- Record the oscillations when they are in phase and determine the period T_+ .
- Record the oscillations when they are out of phase and determine the period T_- .
- Record a coupled oscillation and determine the oscillation period T and the beat period T_Δ .
- Compare the values obtained for those calculated for the natural periods T_+ and T_- .

OBJECTIVE

Record and evaluate oscillation of two identical coupled pendulums

SUMMARY

The oscillation of two identical, coupled pendulums is distinguished by the period of oscillation and the beat period. The beat period is the interval between two points in time when one pendulum is swinging at its minimum amplitude. Both values can be calculated from the natural periods of oscillation for the coupled pendulums when the oscillations are in phase and out of phase.

REQUIRED APPARATUS

Quantity	Description	Number
2	Pendulum Rods with Angle Sensor (230 V, 50/60 Hz)	1000763 or
	Pendulum Rods with Angle Sensor (115 V, 50/60 Hz)	1000762
1	Helical Springs 3,0 N/m	1002945
2	Table Clamps	1002832
2	Stainless Steel Rods 1000 mm	1002936
1	Stainless Steel Rod 470 mm	1002934
4	Multiclamps	1002830
2	HF Patch Cord, BNC/4mm plug	1002748
1	3B NETlog™ (230 V, 50/60 Hz)	1000540 or
	3B NETlog™ (115 V, 50/60 Hz)	1000539
1	3B NETlab™	1000544

2

BASIC PRINCIPLES

For oscillation of two coupled pendulums, the oscillation energy is transferred from one pendulum to the other and back again. If both pendulums are identical and oscillation is begun so that one pendulum is initially at rest while the other is swinging, the energy is actually transferred in its entirety, i.e. one pendulum always comes to rest while the other is swinging at its maximum amplitude. The time between two such occurrences of rest for one pendulum or, more generally, the time between any two instances of minimum amplitude is referred to as the beat period T_Δ .

The oscillation of two identical coupled ideal pendulums can be regarded as a superimposition of two natural oscillations. These natural oscillations can be observed when both pendulums are fully in phase or fully out of phase. In the first case, both pendulums vibrate at the frequency that they would if the coupling to the other pendulum were not present at all. In the second case, the effect of the coupling is at a maximum and the inherent frequency is greater. All other oscillations can be described by superimposing these two natural oscillations.

The equation of motion for the pendulums takes the form:

$$(1) \quad \begin{aligned} L \cdot \ddot{\varphi}_1 + g \cdot \varphi_1 + k \cdot (\varphi_1 - \varphi_2) &= 0 \\ L \cdot \ddot{\varphi}_2 + g \cdot \varphi_2 + k \cdot (\varphi_2 - \varphi_1) &= 0 \end{aligned}$$

g : Acceleration due to gravity, L : length of pendulum, k : coupling constant

For the motions $\varphi_- = \varphi_1 - \varphi_2$ and $\varphi_+ = \varphi_1 + \varphi_2$ (initially chosen arbitrarily) the equation of motion is as follows:

$$(2) \quad \begin{aligned} L \cdot \ddot{\varphi}_+ + g \cdot \varphi_+ &= 0 \\ L \cdot \ddot{\varphi}_- + (g + 2k) \cdot \varphi_- &= 0 \end{aligned}$$

The solutions

$$(3) \quad \begin{aligned} \varphi_+ &= a_+ \cdot \cos(\omega_+ t) + b_+ \cdot \sin(\omega_+ t) \\ \varphi_- &= a_- \cdot \cos(\omega_- t) + b_- \cdot \sin(\omega_- t) \end{aligned}$$

give rise to angular frequencies

$$(4) \quad \begin{aligned} \omega_+ &= \sqrt{\frac{g}{L}} \\ \omega_- &= \sqrt{\frac{g + 2k}{L}} \end{aligned}$$

corresponding to the natural frequencies for in phase or out of phase motion ($\varphi_+ = 0$ for out of phase motion and $\varphi_- = 0$ for in-phase motion).

The deflection of the pendulums can be calculated from the sum or the difference of the two motions, leading to the solutions

$$(5) \quad \begin{aligned} \varphi_1 &= \frac{1}{2} \cdot (a_+ \cdot \cos(\omega_+ t) + b_+ \cdot \sin(\omega_+ t) + a_- \cdot \cos(\omega_- t) + b_- \cdot \sin(\omega_- t)) \\ \varphi_2 &= \frac{1}{2} \cdot (a_+ \cdot \cos(\omega_+ t) + b_+ \cdot \sin(\omega_+ t) - a_- \cdot \cos(\omega_- t) - b_- \cdot \sin(\omega_- t)) \end{aligned}$$

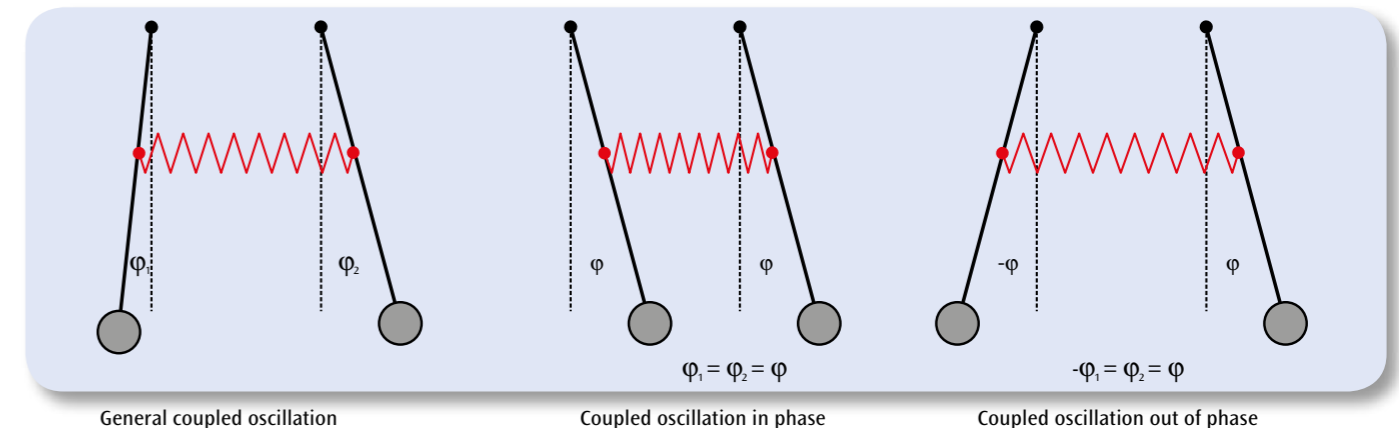

General coupled oscillation

Coupled oscillation in phase

Coupled oscillation out of phase

Parameters a_+ , a_- , b_+ and b_- are arbitrary coefficients that can be calculated from the initial conditions for the two pendulums at time $t = 0$. It is easiest to consider the following case where pendulum 1 is moved at time 0 from rest to an initial angular velocity ψ_0 while pendulum 2 remains at rest.

$$(6) \quad \begin{aligned} \varphi_1 &= \frac{1}{2} \cdot \left(\frac{\psi_0}{\omega_+} \cdot \sin(\omega_+ t) + \frac{\psi_0}{\omega_-} \cdot \sin(\omega_- t) \right) \\ \varphi_2 &= \frac{1}{2} \cdot \left(\frac{\psi_0}{\omega_+} \cdot \sin(\omega_+ t) - \frac{\psi_0}{\omega_-} \cdot \sin(\omega_- t) \right) \end{aligned}$$

The speed of both pendulums is then given by:

$$(7) \quad \begin{aligned} \dot{\varphi}_1 &= \frac{\psi_0}{2} \cdot (\cos(\omega_+ t) + \cos(\omega_- t)) \\ \dot{\varphi}_2 &= \frac{\psi_0}{2} \cdot (\cos(\omega_+ t) - \cos(\omega_- t)) \end{aligned}$$

which can be rearranged to give

$$(8) \quad \begin{aligned} \dot{\varphi}_1 &= \psi_0 \cdot \cos(\omega_\Delta t) \cdot \cos(\omega t) \\ \dot{\varphi}_2 &= \psi_0 \cdot \sin(\omega_\Delta t) \cdot \cos(\omega t) \end{aligned} \quad \text{where (9) } \quad \begin{aligned} \omega_\Delta &= \frac{\omega_- - \omega_+}{2} \\ \omega &= \frac{\omega_+ + \omega_-}{2} \end{aligned}$$

This corresponds to an oscillation of both pendulums at identical angular frequency ω , where the velocity amplitudes ψ_1 and ψ_2 are modulated at an angular frequency ω_Δ :

$$(10) \quad \begin{aligned} \psi_1(t) &= \psi_0 \cdot \cos(\omega_\Delta t) \\ \psi_2(t) &= \psi_0 \cdot \sin(\omega_\Delta t) \end{aligned}$$

EVALUATION

Equation (4) can be used to calculate the natural oscillation periods T_+ and T_- for in-phase and out-of-phase oscillation:

$$T_+ = \frac{2\pi}{\omega_+} = 2\pi \sqrt{\frac{L}{g}} \quad \text{and} \quad T_- = \frac{2\pi}{\omega_-} = 2\pi \sqrt{\frac{L}{g + 2k}}$$

For a period T for coupled oscillation, equation (9) implies the following:

$$\frac{2\pi}{T} = \omega = \frac{\pi}{T_+} + \frac{\pi}{T_-} \quad \text{and therefore} \quad T = 2 \cdot \frac{T_+ \cdot T_-}{T_+ + T_-}$$

The amplitude modulation given in equation (10) is usually stipulated in terms of its period T_Δ corresponding to the time between successive points where one pendulum stands still:

$$\frac{2\pi}{2T_\Delta} = \omega_\Delta = \frac{\pi}{T_-} - \frac{\pi}{T_+} \quad \text{and therefore} \quad T_\Delta = \frac{T_+ \cdot T_-}{T_+ - T_-}$$

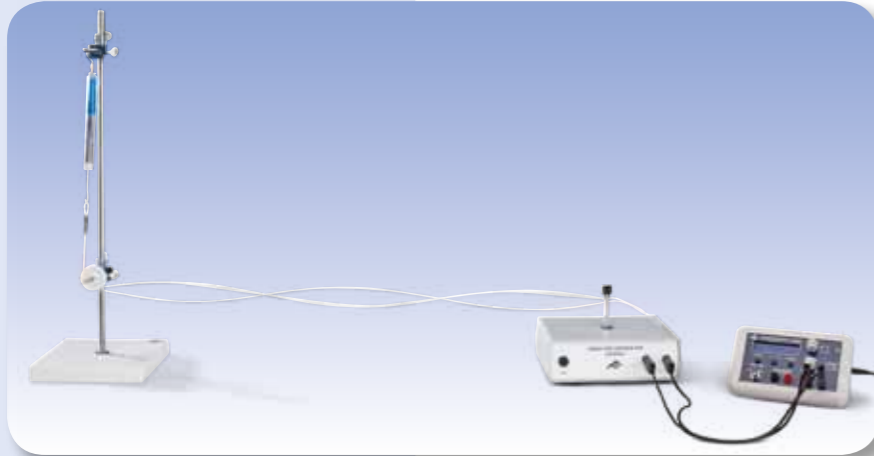

EXPERIMENT PROCEDURE

- Generate standing longitudinal waves in a coil spring and standing transverse waves along a rope.
- Measure the intrinsic frequency f_n as a function of number of nodes n .
- Determine the corresponding wavelength λ_n and speed of propagation of the waves c .

OBJECTIVE

Investigate standing waves along a stretched coil spring and a taut rope

SUMMARY

Some examples of where mechanical waves arise include a stretched coil spring, where the waves are longitudinal, or a taut rope where the waves are transverse. In either case, standing waves will be set up if one end of the carrier medium is fixed. This is because the incoming wave and the wave reflected at the fixed end have the same amplitude and are superimposed on one another. If the other end is also fixed, the only way that waves can propagate is if resonance conditions are met. In this experiment the coil spring and the rope are fixed at one end. The other end, a distance L from the fixed point, is fixed to a vibration generator, which uses a function generator to drive small-amplitude oscillations of variable frequency f . This end can also be regarded as a fixed point to a good approximation. The intrinsic frequency of the vibration will be measured as a function of the number of nodes in the standing wave. The speed of propagation of the wave can then be calculated from this data.

REQUIRED APPARATUS

Quantity	Description	Number
1	Accessories for Spring Oscillations	1000703
1	Accessories for Rope Waves	1008540
1	Vibration Generator	1000701
1	Function Generator FG 100 (230 V, 50/60 Hz)	1009957 or
1	Function Generator FG 100 (115 V, 50/60 Hz)	1009956
1	Precision Dynamometer, 2 N	1003105
1	Pocket Measuring Tape, 2 m	1002603
1	Pair of Safety Experimental Leads, 75 cm, red/blue	1017718

BASIC PRINCIPLES

Some examples of where mechanical waves arise include a stretched coil spring or a taut rope. The waves arising in the spring are longitudinal waves since the deflection of the coil is in the direction of propagation. The waves along a rope by contrast are transverse waves. This is because the incoming wave and the wave reflected at the fixed end have the same amplitude and are

superimposed on one another. If the other end is also fixed, the only way that waves can propagate is if resonance conditions are met.

Let $\xi(x,t)$ be the longitudinal or transverse deflection at a point x along the carrier medium at a point in time t . The following is then true:

$$(1) \quad \xi_1(x,t) = \xi_0 \cdot \cos(2\pi \cdot f \cdot t - \frac{2\pi}{\lambda} \cdot x)$$

This applies to a sinusoidal wave travelling from left to right along the carrier medium. The frequency f and wavelength λ are related in following way:

$$(2) \quad c = f \cdot \lambda$$

c : Propagation velocity of wave

If such a wave, travelling from left to right, should be reflected from a fixed point at $x = 0$, a wave travelling from right to left direction then arises.

$$(3) \quad \xi_2(x,t) = -\xi_0 \cdot \cos(2\pi \cdot f \cdot t + \frac{2\pi}{\lambda} \cdot x)$$

The two waves are then superimposed to create a standing wave.

$$(4) \quad \xi(x,t) = 2\xi_0 \cdot \sin(2\pi \cdot f \cdot t) \cdot \sin(\frac{2\pi}{\lambda} \cdot x)$$

These considerations are valid regardless of the nature of the wave or of the carrier medium.

If the other end is also fixed at a position $x = L$, then the following resonance condition needs to be fulfilled at all times t .

$$(5) \quad \xi(L,t) = 0 = \sin(\frac{2\pi}{\lambda} \cdot L)$$

This only applies if the wavelength meets the following conditions:

$$(6a) \quad \frac{2\pi}{\lambda_n} \cdot L = (n+1) \cdot \pi, \quad \lambda_n = 2 \cdot \frac{L}{n+1}$$

$$\text{or } L = (n+1) \cdot \frac{\lambda_n}{2}$$

According to equation (2), the frequency is then

$$(6b) \quad f_n = (n+1) \cdot \frac{c}{2 \cdot L}$$

This implies that the condition for resonance (5) is only fulfilled if the length L is an integer multiple of half the wavelength. The resonant frequency must correspond to this wavelength. In this case, n is the number of nodes in the oscillation. This is zero if there is only one anti-node in the fundamental oscillation (see Fig. 2).

In this experiment, the carrier medium is either a spring or a rope which is fixed at one end. The other end is connected to a vibration generator at a distance L from this fixed point. This uses a function generator to drive small-amplitude oscillations of variable frequency f . This end can also be regarded as a fixed point to a good approximation.

EVALUATION

If resonant frequency is plotted against the number of nodes, the points will all lie along a straight line of gradient

$$\alpha = \frac{c}{2 \cdot L}$$

Therefore, as long as the length L is known, it is possible to calculate the speed of propagation of the wave c . With all other parameters being equal it is dependent on the tensile force F , as Fig. 5 demonstrates for the waves along the rope.

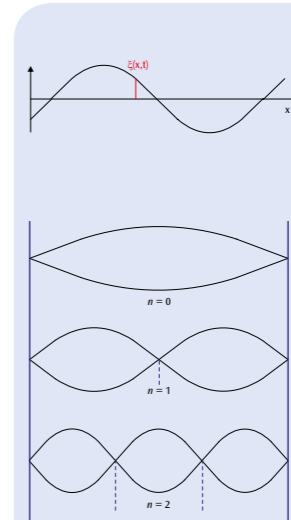

Fig. 1: Illustration of how the localised deflection $\xi(x,t)$ is defined

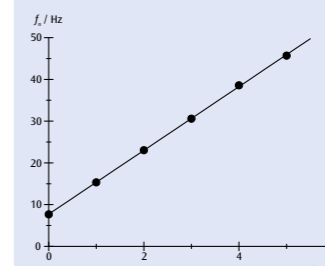

Fig. 3: Resonant frequency as a function of the number of nodes for waves along a coil spring

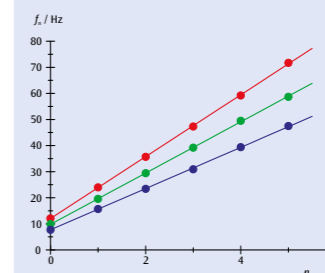

Fig. 4: Resonant frequency as a function of the number of nodes for waves along a rope

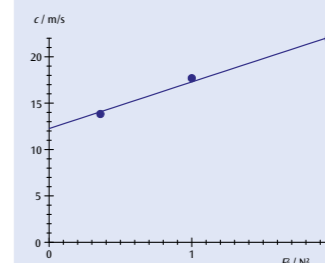
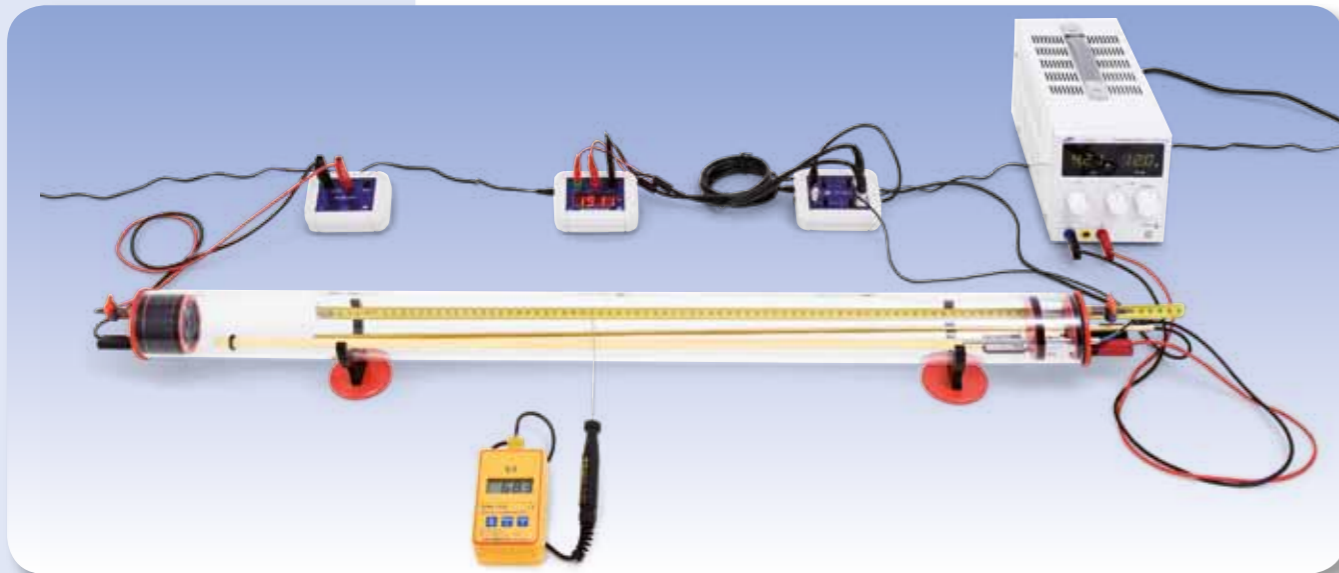

Fig. 5: Wave velocity c as a function of F^2 for the waves along a rope



EXPERIMENT PROCEDURE

- Measuring the propagation time t of a sound pulse in air at room temperature as a function of the distance s between two microphone probes.
- Confirming the linear relationship between s and t .
- Measuring the propagation time t of a sound pulse in air as a function of the temperature T over a fixed distance between two microphone probes.
- Determining the speed of sound (group velocity) as a function of temperature.
- Comparing the result with Laplace's derivation.



OBJECTIVE

Measuring the propagation time of sound pulses in Kundt's tube

SUMMARY

Sound waves propagate longitudinally in gases. The group velocity here is equal to the phase velocity. In this experiment, we will measure the propagation time of a sound pulse between two microphone probes in Kundt's tube, and use the result to calculate the speed of sound. The temperature dependence of the speed of sound is examined between room temperature and 50°C. The measurement result matches the result of Laplace's derivation.

REQUIRED APPARATUS

Quantity	Description	Number
1	Kundt's Tube E	1017339
1	Pulse Box K	1017341
1	Probe Microphone, long	1017342
1	Microphone Probe, short	4008308
1	Microphone Box (230 V, 50/60 Hz)	1014520 or
	Microphone Box (115 V, 50/60 Hz)	1014521
1	Microsecond Counter (230 V, 50/60 Hz)	1017333 or
	Microsecond Counter (115 V, 50/60 Hz)	1017334
1	Heating Rod K	1017340
2	HF Patch Cord, BNC/4 mm Plug	1002748
1	DC Power Supply 0 – 20 V, 0 – 5 A (230 V, 50/60 Hz)	1003312 or
	DC Power Supply 0 – 20 V, 0 – 5 A (115 V, 50/60 Hz)	1003311
1	Digital Quick Response Pocket Thermometer	1002803
1	K-Type NiCr-Ni Immersion Sensor, -65°C – 550°C	1002804
1	Pair of Safety Experiment Leads, 75 cm	1002849

Additionally recommended:

a variety of technical gases

BASIC PRINCIPLES

Sound waves are elastic waves within a deformable medium. The wave velocity depends on the medium's elastic properties. In simple gases, sound propagates exclusively as longitudinal waves, the group velocity being equal to the phase velocity.

In a derivation according to Laplace, sound waves in gases are considered as changes in adiabatic pressure or density. The speed of sound is determined as being:

$$(1) \quad c = \sqrt{\frac{C_p \cdot p}{C_v \cdot \rho}}$$

p : Pressure. ρ : Density.

C_p, C_v : Heat capacities of the gas

For an ideal gas at absolute temperature T :

$$(2) \quad \frac{p}{\rho} = \frac{R \cdot T}{M}$$

$R = 8,314 \frac{J}{Mol \cdot K}$: Universal gas constant.

M : Molar mass

The speed of sound in this gas is therefore:

$$(3) \quad c = \sqrt{\frac{C_p \cdot R \cdot T}{C_v \cdot M}}$$

For temperature differences ΔT which are not too large compared to a reference temperature T_0 , the speed of sound is a linear function of the temperature change ΔT :

$$(4) \quad c = \sqrt{\frac{C_p \cdot R \cdot T_0}{C_v \cdot M}} \cdot \left(1 + \frac{\Delta T}{2 \cdot T_0}\right)$$

For dry air as an ideal gas, the speed of sound is accordingly often expressed as follows:

$$(5) \quad c(T) = \left(331,3 + 0,6 \cdot \frac{\Delta T}{K}\right) \frac{m}{s}$$

$T_0 = 273,15 \text{ K} = 0^\circ\text{C}$

In the experiment, we will measure the propagation time t of a sound pulse between two microphone probes spaced at a distance s . The sound pulse is produced by a sudden movement of a loudspeaker diaphragm controlled by a voltage pulse with steep edge. High-resolution measurement of the propagation time using a microsecond counter starts when the sound pulse reaches the first microphone probe, and stops when the second microphone probe at a distance s is reached.

A heating element is used to heat the air in Kundt's tube to up to 50°C for measurements of propagation time as a function of temperature. The temperature distribution during the cooling process is sufficiently homogeneous. It is therefore sufficient to measure the temperature at one point in Kundt's tube.

A tube connector can be used to supply Kundt's tube with technical gases other than air.

EVALUATION

The speed of sound is calculated as the quotient of the travelled distance s and the propagation time t :

$$c = \frac{s}{t}$$

Figure 2 represents it as the reciprocal of the slope.

The temperature dependence of the speed of sound is described by equation 3 with the following parameters:

$$M = 28,97 \frac{g}{Mol}, \quad \frac{C_p}{C_v} = \frac{7}{5}$$

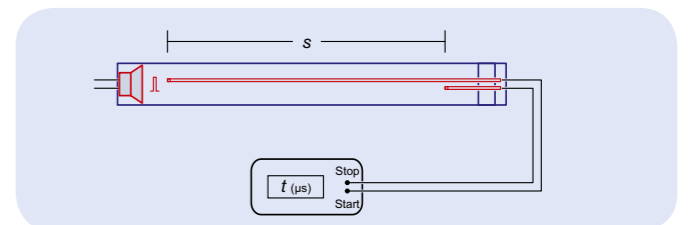

Fig. 1: Schematic of the experiment setup

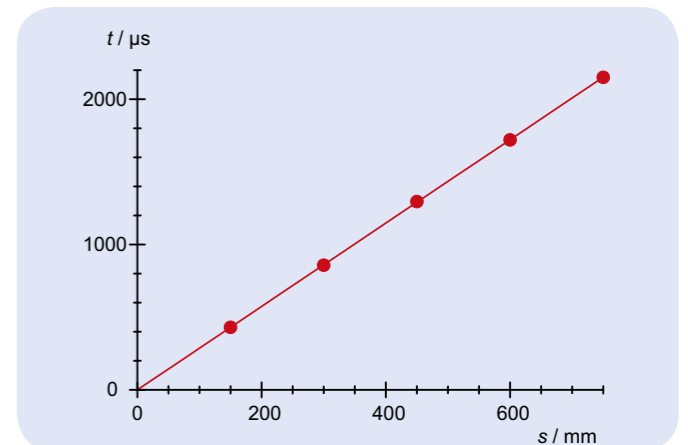

Fig. 2: Sound propagation time t in air as a function of the travelled distance s at room temperature

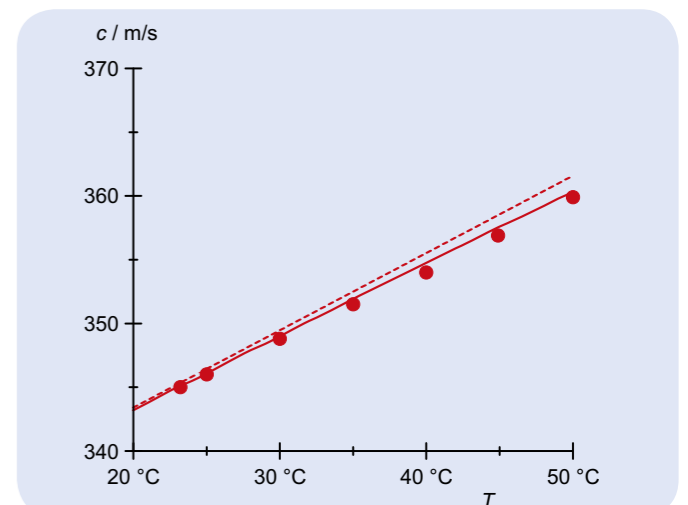
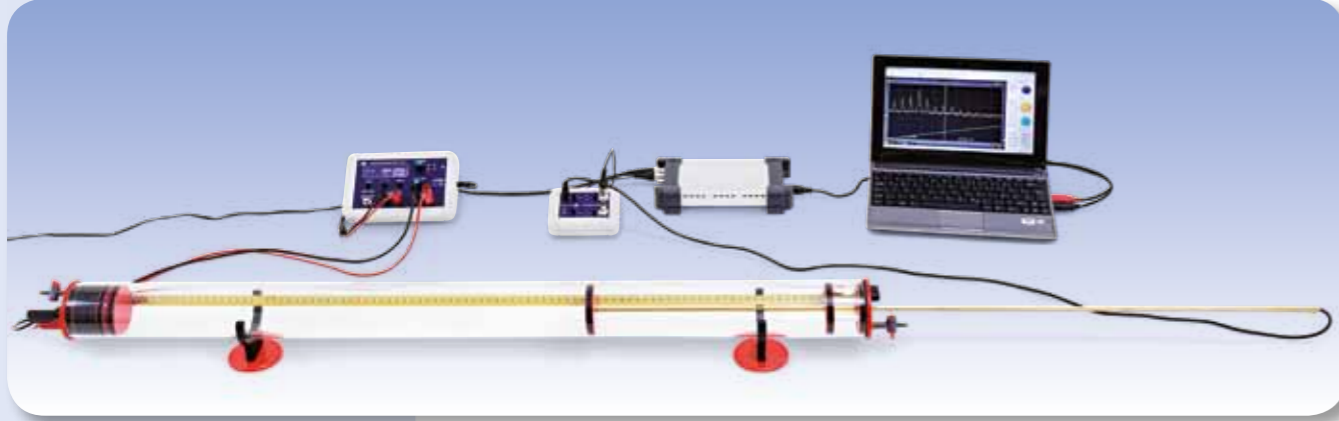

Fig. 3 Speed of sound c in air as a function of the temperature T
Solid line: Calculation according to equation 3
Dashed line: Calculation according to equation 5



EXPERIMENT PROCEDURE

- Generate standing waves in Kundt's tube with both ends closed off.
- Measure the fundamental frequency as a function of the length of the Kundt's tube.
- Measure the frequencies of the fundamental and overtones for a fixed length of tube.
- Determine the speed of propagation of the wave from the resonant frequencies.

OBJECTIVE

Generate and measure standing sound waves in Kundt's tube

SUMMARY

Sound waves propagate in gases in the form of longitudinal waves. The overall velocity is equivalent to the phase velocity. In this experiment a standing wave is generated inside Kundt's tube with both ends closed off. The fundamental frequency is measured as a function of the length of the tube, and the frequencies of the fundamental and overtones are also measured for a fixed length of tube.

REQUIRED APPARATUS

Quantity	Description	Number
1	Kundt's Tube E	1017339
1	Probe Microphone, long	1017342
1	Microphone Box (115 V, 50/60 Hz)	1014521 or
	Microphone Box (230 V, 50/60 Hz)	1014520
1	Function Generator FG 100 (230 V, 50/60 Hz)	1009957 or
	Function Generator FG 100 (115 V, 50/60 Hz)	1009956
1	USB Oscilloscope 2x50 MHz	1017264
1	Analogue Multimeter AM50	1003073
1	HF Patch Cord, BNC/4 mm Plug	1002748
1	Pair of Safety Experiment Leads, 75 cm	1002849
1	HF Patch Cord	1002746

BASIC PRINCIPLES

It is possible to generate standing waves in Kundt's tube by producing waves of a suitable resonant frequency from a loudspeaker at one end of the tube, which are then reflected by the cap at the other end. If the length of the tube is known, it is possible to determine the speed of propagation of the waves from the resonant frequency and the number of the harmonics.

Sound waves propagate in air and other gases by means of rapid changes in pressure and density. It is easiest to describe them on the basis of the sound pressure, which is superimposed on top of atmos-

pheric pressure. As an alternative to the sound pressure p , the sound velocity v can also be used to describe a sound wave. That is the average velocity of gas molecules at a given point x in the oscillating medium at a point in time t . Pressure and velocity of sound are linked, for example by an Euler equation of motion:

$$(1) \quad -\frac{\partial p}{\partial x} = \rho_0 \cdot \frac{\partial v}{\partial t}$$

ρ_0 : Density of gas

In Kundt's tube, sound waves propagate along the length of the tube, i.e. they can be described with the help of a one-dimensional wave equation, which applies to both sound pressure and velocity:

$$(2) \quad \text{or} \quad \begin{aligned} \frac{\partial^2 p(x,t)}{\partial t^2} &= c^2 \cdot \frac{\partial^2 p(x,t)}{\partial x^2} \\ \frac{\partial^2 v(x,t)}{\partial t^2} &= c^2 \cdot \frac{\partial^2 v(x,t)}{\partial x^2} \end{aligned}$$

c : speed of sound

This experiment studies harmonic waves, which are reflected at the end of the Kundt's tube. To find the solutions to the wave equation, the superposition of the outgoing and reflected waves needs to be taken into account:

$$(3) \quad p = p_{0>} \cdot e^{2\pi i \left(f t - \frac{x}{\lambda} \right)} + p_{0<} \cdot e^{2\pi i \left(f t + \frac{x}{\lambda} \right)}$$

$p_{0>}, v_{0>}$: Amplitudes of outgoing wave,
 $p_{0<}, v_{0<}$: Amplitudes of returning wave
 f : Frequency, λ : Wavelength

In this case

$$(4) \quad f \cdot \lambda = c$$

By substituting these solutions into equation (1) and considering the outgoing and returning waves separately, the following can be derived:

$$(5) \quad p_{0>} = v_{0>} \cdot Z \quad \text{and} \quad p_{0<} = v_{0<} \cdot Z$$

The quantity

$$(6) \quad Z = c \cdot \rho_0$$

is known as the sound impedance and corresponds to the resistance to the waves from the medium itself. It plays a key role in considerations of the reflection of a sound wave by walls with an impedance of W :

The following then applies:

$$(7) \quad r_v = \frac{v_{0<}}{v_{0>}} = \frac{Z - W}{Z + W} \quad \text{and} \quad r_p = \frac{p_{0<}}{p_{0>}} = \frac{1 - \frac{W}{Z}}{1 + \frac{W}{Z}}$$

In this experiment W is much higher than Z so that we may assume $r_v = 1$ and $r_p = -1$.

If the reflecting wall is selected, for simplicity's sake, to be at $x = 0$, the spatial component of the sound wave can be derived from equation (3) as follows:

$$(8) \quad p = p_{0>} \cdot \left(e^{-2\pi i \frac{x}{\lambda}} + e^{+2\pi i \frac{x}{\lambda}} \right) \cdot e^{-2\pi i f t}$$

$$= 2 \cdot p_{0>} \cdot \cos\left(\frac{2\pi}{\lambda} \cdot x\right) \cdot e^{-2\pi i f t}$$

and

$$v = v_{0>} \cdot \left(e^{-2\pi i \frac{x}{\lambda}} - e^{+2\pi i \frac{x}{\lambda}} \right) \cdot e^{-2\pi i f t}$$

$$= -2 \cdot i \cdot v_{0>} \cdot \sin\left(\frac{2\pi}{\lambda} \cdot x\right) \cdot e^{-2\pi i f t}$$

Only the real components of these terms have any actual physical relevance. They correspond to standing sound waves which have a pressure anti-node at the end wall (i.e. at $x = 0$), while the sound velocity at that

point has a node in its oscillation. The velocity is phase shifted ahead of the pressure by 90° .

Sound waves are generated by a loudspeaker at a distance L from the wall. These waves oscillate with frequency f . At this point, too, the pressure has an anti-node and the velocity has a node. Such boundary conditions are only fulfilled when L is an integer multiple of half the wavelength:

$$(9) \quad L = n \cdot \frac{\lambda_n}{2}$$

From equation (3) then, the frequencies must fulfil the following condition for resonance:

$$(10) \quad f_n = n \cdot \frac{c}{2 \cdot L}$$

During the experiment, the frequency f of the speaker is continuously varied while a microphone sensor measures the sound pressure at the reflecting wall. Resonance then occurs when the microphone signal is at its maximum amplitude.

EVALUATION

According to equation (9) the resonant frequencies determined f_n should have wavelengths

$$\lambda_n = \frac{2 \cdot L}{n}$$

In order to verify equation (3) and determine the wavelength, the wavelength values should be plotted on a graph of f against λ .

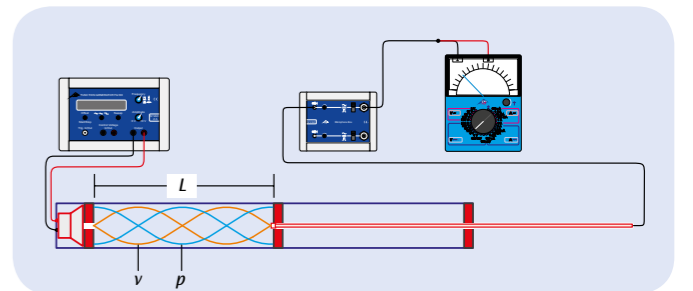

Fig. 1: Schematic of experiment set-up

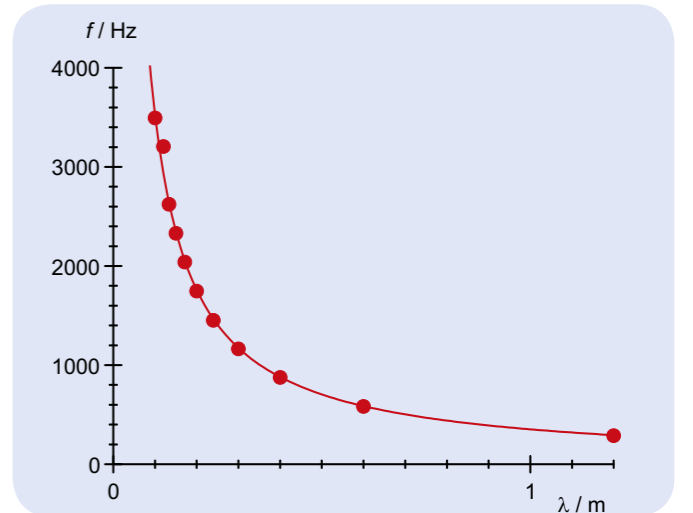
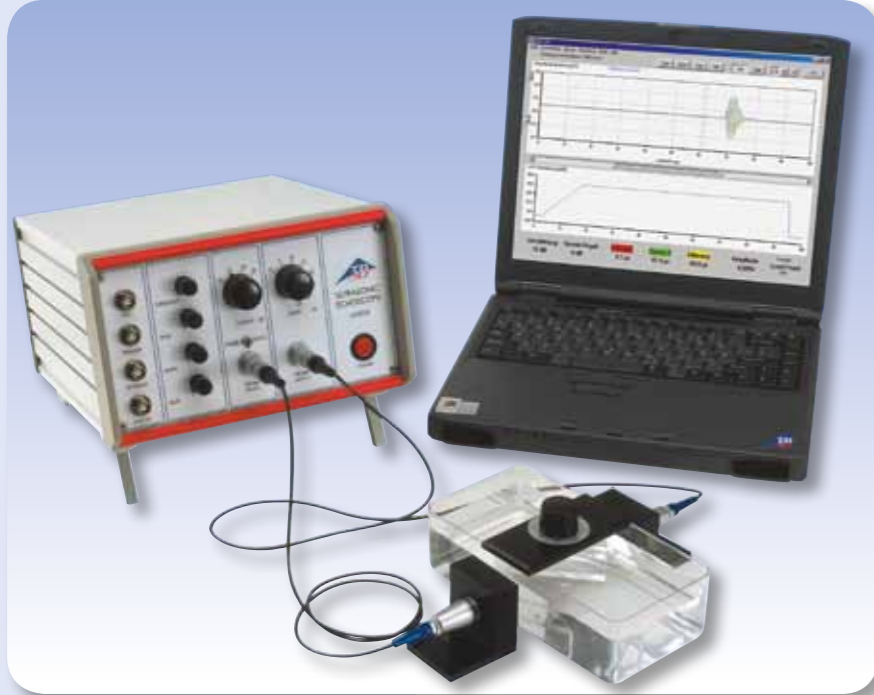

Fig. 2: Graph of frequency against wavelength

OBJECTIVE

Determine the speeds of sound propagated by longitudinal and transverse waves in solids

SUMMARY

In solids, sound is propagated in the form of longitudinal and transverse waves. However, there is a considerable difference in the speed of the two types of sound waves, since longitudinal sound waves are determined by the elastic modulus of the solid, whereas transverse sound waves are dependent on the shear modulus of the solid. By measuring the speed of the two wave types, it is possible to determine the elastic constant of the solid.

EXPERIMENT PROCEDURE

- To determine the speed of sound for longitudinal waves in polyacrylic from the propagation time of a 1-MHz ultrasound signal.
- To measure the transmission of longitudinal and transverse sound waves in solids through an inclined, plane-parallel plate.
- To determine the speed of sound for longitudinal and transverse waves from the critical angle of total reflection.
- To determine the elastic modulus E , the shear modulus G and Poisson's ratio of a solid μ from the two speeds.

REQUIRED APPARATUS

Quantity	Description	Number
1	Ultrasonic Echoscope	1002580
2	Ultrasonic Transducers, 1 MHz	1002581
1	Longitudinal and Transversal Wave Equipment Kit	1002584
1	Aluminum Test Block with Protractor Scale	1002585
1	Set of 3 Cylinders	1002588
1	Ultrasonic Coupling Gel	1008575

BASIC PRINCIPLES

In gases and liquids, sound is propagated exclusively in the form of longitudinal waves. In the process, the sound pressure oscillates around an equilibrium value and generates oscillating regions of compression and rarefaction. Sound also penetrates solids in the form of transverse waves in which the shear stress oscillates. Transverse waves can propagate through solids because solids possess the necessary shear force required for conducting sound.

Longitudinal and transverse waves possess different speeds which depend on the density ρ and the elastic constant of the solid. The speed of longitudinal waves, given by

$$(1) \quad c_L = \sqrt{\frac{E}{\rho} \cdot \frac{1-\mu}{(1+\mu)(1-2\mu)}}$$

E : elastic modulus, μ : Poisson's ratio

is greater than that of transverse waves

$$(2) \quad c_T = \sqrt{\frac{G}{\rho}}$$

G : shear modulus

2

The relation between the elastic modulus E , shear modulus G of a solid and Poisson's ratio is given by the following equation:

$$(3) \quad \frac{E}{G} = 2 \cdot (1 + \mu)$$

It is therefore possible to calculate all three magnitudes of elasticity, given that the two sound speeds c_L and c_T are known.

In the experiment, first measure the propagation time t of a 1-MHz ultrasound signal through three polyacrylic cylinders of different lengths s . Plot the values in an s - t graph (see Fig. 1). From the inclination of the best-fit line through the measured values, we get the longitudinal sound speed in polyacrylic.

Subsequently, fill a trough with water and place it in the path of the wave. Measure the transit time. The transit time is reduced by placing a thin plane-parallel plate made of polyacrylic or aluminium in the path of the wave. This is due to the fact that sound propagates faster in the plate material than in water. Take accurate readings behind the water trough for the two distinct ultrasound signals caused due to the different propagation times for longitudinal and transversal sound waves in solids (see Fig. 2). If the plate is inclined at an angle α to the incident wave, then, according to Snell's law, the wave is refracted and the two refracted waves are at angles β_L and β_T (see Fig. 3).

$$(4) \quad \frac{c}{\sin \alpha} = \frac{c_L}{\sin \beta_L} = \frac{c_T}{\sin \beta_T}$$

c : speed of sound in water

As the two sound speeds c_L and c_T through the solid are greater than the speed of sound c in water, we can eventually observe the phenomenon of total reflection – distinctly for longitudinal and transverse waves – in which the transmitted signals fully disappear. The corresponding speeds can be measured from the critical angles α_L for longitudinal waves and α_T for transverse waves:

$$(5) \quad c_L = \frac{c}{\sin \alpha_L} \quad \text{and} \quad c_T = \frac{c}{\sin \alpha_T}$$

EVALUATION

a) The readings from the first series of propagation time measurements are not on a straight line through the origin on the s - t graph. This is because the propagation time required by the signal to pass through the adaptation and protective layer of the ultrasonic transducer is also measured systematically.

b) From equations 1 to 3, we get the characteristic equation for Poisson's ratio μ

$$\mu = \frac{\frac{1}{2} \cdot \left(\frac{c_L}{c_T}\right)^2 - 1}{\left(\frac{c_L}{c_T}\right)^2 - 1}$$

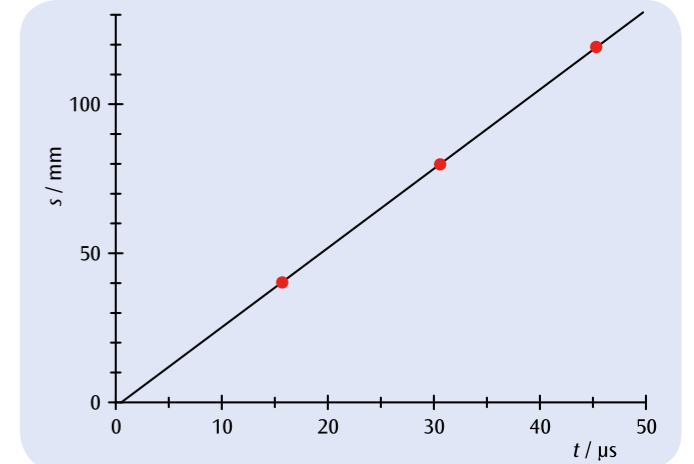

Fig. 1: s - t graph of an ultrasound signal in polyacrylic

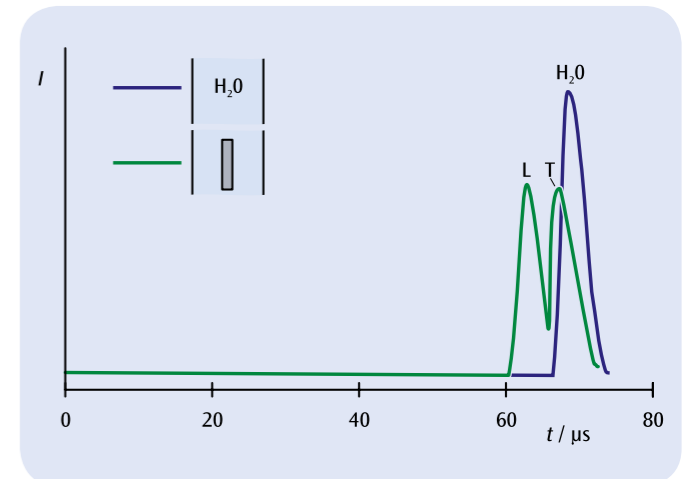

Fig. 2: Ultrasound signal after penetrating a water trough (blue: without plane-parallel plate, green: with plane-parallel plate)

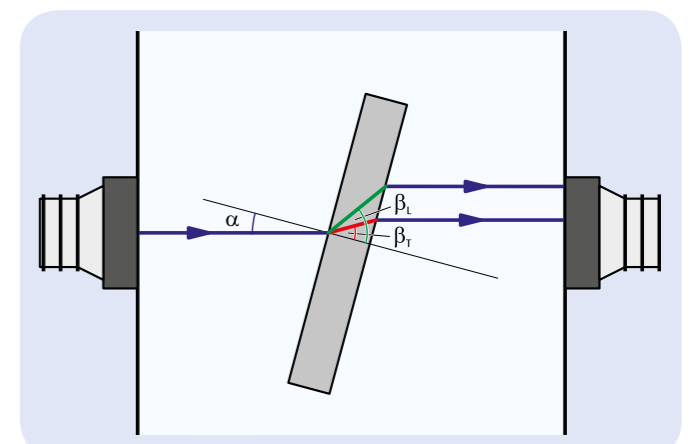

Fig. 3: Experimental set-up for determining the speed of sound for longitudinal and transverse waves from the critical angles of total reflection



EXPERIMENT PROCEDURE

- Observing the diffraction pattern at a fixed ultrasound frequency for two different light wavelengths.
- Observing the diffraction pattern for different ultrasound frequencies between 1 MHz and 12 MHz.
- Determining the corresponding sound wavelengths and the velocity of sound.

OBJECTIVE

Determine the velocity of ultrasonic waves in liquids

SUMMARY

The periodic variations of density caused by an ultrasonic standing wave pattern in a liquid act as an optical grating for the diffraction of a monochromatic parallel light beam that is transmitted in the direction perpendicular to the direction of the ultrasound wave. From the diffraction pattern and the known wavelength of the light, it is possible to determine the sound wavelength and use that to calculate the velocity of sound in the liquid.

REQUIRED APPARATUS

Quantity	Description	Number
1	Ultrasonic cw Generator	1002576
1	Test Vessel	1002578
1	Laser Diode for Debye-Sears Effect, Red	1002577
1	Laser Diode for Debye-Sears Effect, Green	1002579
1	Pocket Measuring Tape, 2 m	1002603
1	Ultrasonic Coupling Gel	1008575

3

BASIC PRINCIPLES

The diffraction of light by ultrasonic waves in liquids was predicted by Brillouin in 1922, and the effect was confirmed experimentally in 1932 by Debye and Sears and also by Lucas and Biquard. It is caused by the periodic variations in the refractive index of the liquid that are produced by ultrasonic waves. If a light beam is passed through the liquid perpendicular to the ultrasound direction, the arrangement acts as a phase grating, which moves depending on the velocity of sound. Its grating constant corresponds to the wavelength of the ultrasound, and thus depends on its frequency and the velocity of sound in the medium. The movement of the phase grating can be neglected if the effect is observed on a screen at a large distance.

In the experiment, a vertically orientated generator couples ultrasonic waves at frequencies between 1 MHz and 12 MHz into the test liquid. A monochromatic parallel light beam passes through the liquid in the horizontal direction and is diffracted by the phase grating. The diffraction pattern contains several diffraction maxima spaced at regular distances.

The k -th-order maximum of the diffraction pattern is found at the diffraction angle α_k , defined by

$$(1) \quad \tan \alpha_k = k \cdot \frac{\lambda_L}{\lambda_S}$$

λ_L : light wavelength, λ_S : ultrasound wavelength.

Thus, the ultrasound wavelength λ_S can be determined from the separation between the diffraction maxima. Furthermore, according to the relationship

$$(2) \quad c = f \cdot \lambda_S$$

it is possible to calculate the velocity of sound c in the liquid, since the frequency f of the ultrasonic waves is also known.

EVALUATION

It is necessary to measure the distance s between the ultrasound generator and the screen used to observe the diffraction pattern, and the distance x_{2k} between the $-k$ th and the $+k$ th diffraction maxima. From these two distances, it is possible to calculate the diffraction angle α_k for the k th-order maximum, given by:

$$\tan \alpha_k = \frac{x_{2k}}{2 \cdot s}$$

This leads to the following equation for determining the ultrasound wavelength λ_S :

$$\lambda_S = \frac{2 \cdot k \cdot s}{x_{2k}} \cdot \lambda_L$$

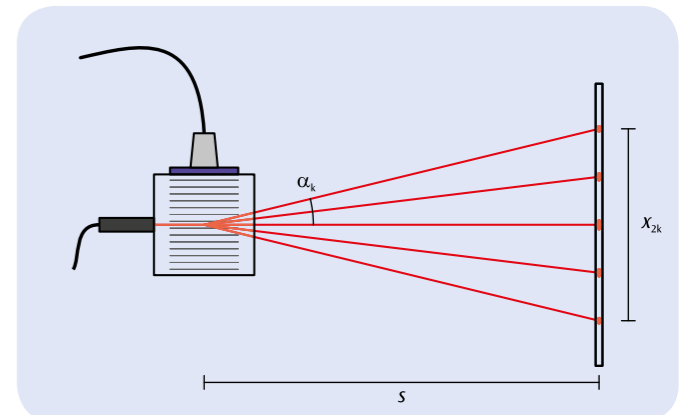

Fig. 1: Diagram showing the diffraction of light by a phase grating that is produced in a liquid by ultrasonic waves (Debye-Sears effect)

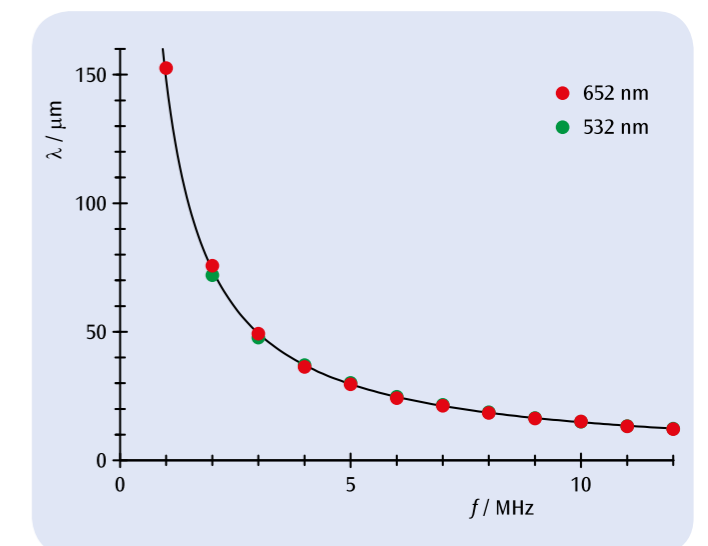

Fig. 2: Sound wavelength λ_S in water as a function of the frequency f



EXPERIMENT PROCEDURE

- Measure the time it takes a sphere to fall through an aqueous solution of glycerine as a function of temperature.
- Determine the dynamic viscosity and compare it with values quoted in literature.
- Compare the way the dynamic viscosity depends on temperature with the predictions of the Andrade equation and determine the activation energy.

OBJECTIVE

Determine the dynamic viscosity of an aqueous solution of glycerine

SUMMARY

Dynamic viscosity, the coefficient of proportionality between velocity gradient and shear stress in a liquid, characterises how difficult it is for an object to flow through the liquid. This can be measured using a falling sphere viscosimeter of a type designed by Höppler. It is also possible to make temperature-independent measurements in conjunction with a circulation thermostat. Measurements are made in an experiment involving an aqueous solution of glycerine. This allows the way that viscosity depends on temperature to be described by the Andrade equation.

REQUIRED APPARATUS

Quantity	Description	Number
1	Falling Sphere Viscometer	1012827
1	Digital Stopwatch	1002811
1	Immersion/Circulation Thermostat (230 V, 50/60 Hz)	1008654 or
	Immersion/Circulation Thermostat (115 V, 50/60 Hz)	1008653
2	Tubing, Silicone 6 mm	1002622
1	Glycerine, 85%, 250 ml	1007027
1	Funnel	1003568
Additionally recommended:		
1	Set of 10 Beakers, Low Form	1002872
2	Graduated Cylinder, 100 ml	1002870
	Distilled water, 5 l	

2

BASIC PRINCIPLES

The viscosity of a fluid results from the mutual bonding interaction between the fluid's atoms or molecules. The component particles are less mobile the stronger the bonding. It then requires a greater shear stress for a velocity gradient to form in a flow profile. The proportionality between the velocity gradient and the shear stress is a measure of how viscous the fluid is, in this case its dynamic or shear viscosity. Fluids in which the dynamic viscosity is not dependent on the shear stress are known as Newtonian fluids.

The dynamic viscosity η of most fluids decreases with increasing temperature. This decrease can often be described with the help of the Andrade equation.

$$(1) \quad \eta = \eta_0 \cdot \exp\left(\frac{E_A}{R \cdot T}\right)$$

E_A : activation energy of atoms/molecules in the fluid
 T : absolute temperature

$$R = 8,314 \frac{\text{J}}{\text{mol} \cdot \text{K}} : \text{universal gas constant}$$

Dynamic viscosity is often measured by observing how a sphere sinks through a fluid as a result of gravity. The sinking is slowed by so-called Stokes' drag

$$(2) \quad F_1 = \eta \cdot 6\pi \cdot r \cdot v$$

r : radius of sphere

This causes it to fall with a constant velocity v . The effect of gravity is lessened by the updraught of the fluid on the sphere:

$$(3) \quad F_2 = \frac{4\pi}{3} \cdot r^3 \cdot (\rho_0 - \rho) \cdot g$$

ρ_0 : density of sphere
 ρ : density of fluid being investigated
 g : acceleration due to gravity

This results in equilibrium between the forces F_1 and F_2 :

$$(4) \quad \eta = \frac{2}{9} \cdot r^2 \cdot g \cdot (\rho_0 - \rho) \cdot \frac{t}{s}$$

t : time taken to sink the above distance

In fact, equation (2) only describes the drag on the sphere in cases where the diameter of the measuring cylinder filled with the fluid is much greater than that of the sphere. This would necessitate using a large quantity of the test fluid. In practice therefore, it is common to use a Höppler falling sphere viscosimeter, which uses a cylinder inclined to the vertical, such that the sphere descends by rolling and slipping down the side of the tube. In this case, the equation for the dynamic viscosity is as follows:

$$(5) \quad \eta = t \cdot (\rho_0 - \rho) \cdot K$$

The calibration factor K is individually quoted for each sphere supplied by the manufacturer. In order to avoid any systematic errors, the measuring cylinder can be inverted, so that the time the sphere takes to sink back to where it started can be measured as well.

This experiment studies common or garden glycerine, which is actually made up of an aqueous solution of glycerine with a glycerine content of

roughly 85%. This dilution is intentional, since the viscosity of pure glycerine is too high for many applications. The viscosity is measured as a function of temperature. For this purpose, the viscosimeter is linked to a circulation thermostat. By diluting the glycerine solution to a specific extent with distilled water, it is also possible to measure how the viscosity depends on concentration.

EVALUATION

Comparing the measured viscosity with values quoted in literature confirms the values specified by the manufacturer. Equation (1) can be rearranged into the following form: $\ln \eta = \ln \eta_0 + E_A \cdot \frac{1}{R \cdot T}$

This means $y = \ln \eta$ can be plotted against $x = \frac{1}{R \cdot T}$ and the activation energy E_A can be determined from the gradient of the resulting straight lines.

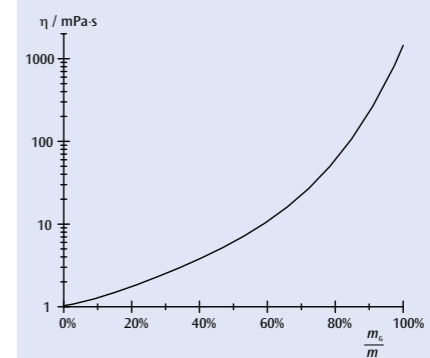

Fig. 1: Dynamic viscosity of an aqueous solution of glycerine at 20°C as a function of the concentration by mass (interpolation of quoted values)

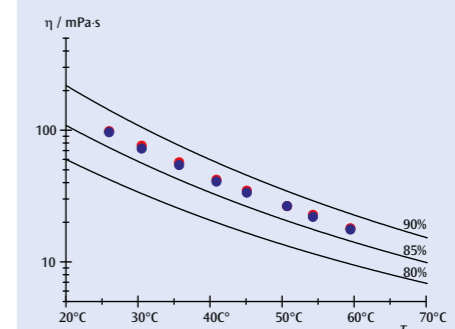

Fig. 2: Dynamic viscosity of an aqueous solution of glycerine as a function of temperature (comparison of measurement with an interpolation of quoted values)

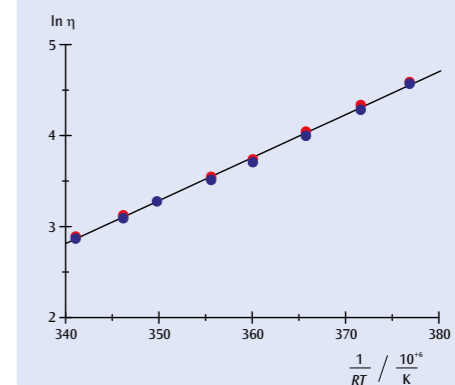

Fig. 3: Graph verifying the Andrade equation and allowing determination of activation energy ($E_A = 47 \text{ kJ/mol}$)

OBJECTIVE

Measure the surface tension by the “break-away” method

SUMMARY

To determine the surface tension of a liquid, a blade is immersed horizontally in the liquid and is slowly pulled out upwards while measuring the pulling force. The lamella of liquid that forms at the blade “breaks away” when the force exceeds a certain value. From this force and the length of the blade one can calculate the surface tension.

EXPERIMENT PROCEDURE

- Forming a lamella of liquid between a ring-shaped blade and the surface of the liquid by slowly lifting the ring out of the liquid.
- Measuring the pulling force shortly before the liquid lamella breaks away.
- Determining the surface tension from the measured pulling force.

2
REQUIRED APPARATUS

Quantity	Description	Number
1	Surface Tension Ring	1000797
1	Precision Dynamometer 0,1 N	1003102
1	Beaker	1002872
1	Laboratory Jack II	1002941
1	Tripod Stand 150 mm	1002835
1	Stainless Steel Rod 470 mm	1002934
1	Clamp with Hook	1002828
1	Callipers, 150 mm	1002601

BASIC PRINCIPLES

The surface tension of a liquid is a property of the interface between the liquid and the air in contact with it. It results from the fact that a molecule of the liquid at the surface only experiences the forces from its neighbouring molecules at one side, whereas a molecule within the liquid experiences forces from all sides (see Fig. 1). Consequently, the molecule at the surface experiences a net force perpendicular to the surface towards the interior of the liquid. Therefore, in order to increase the surface area by bringing more molecules to the surface, a supply of energy is required.

The quotient

$$(1) \quad \sigma = \frac{\Delta E}{\Delta A}$$

resulting from energy ΔE added at a constant temperature divided by the increase in the surface area ΔA , is called surface tension or surface energy density.

To illustrate the meaning of this definition, consider the example of the ring-shaped blade which is initially completely immersed in the liquid. If the ring is slowly pulled out of the liquid, a lamella of liquid is also drawn upwards at its bottom edge (see Fig. 2). When the ring is lifted by an additional distance Δx , the total surface area of the lamella at the outside and inside of the ring increases by

$$(2) \quad \Delta A = 4 \cdot \pi \cdot R \cdot \Delta x$$

where R : radius of the ring.

For this, a force

$$(3) \quad F_0 = \frac{\Delta E}{\Delta x}$$

must be applied. If the force applied while lifting the ring exceeds F_0 , the liquid lamella breaks away.

In the experiment, a metal ring with a sharp lower edge hangs in a horizontal position from a precision dynamometer. At first, the ring is completely immersed in the test liquid (e.g. water), then it is slowly pulled upwards out of the liquid. The lamella of liquid breaks away when the pulling force F exceeds the limiting value F_0 .

EVALUATION

From Equations (1), (2) and (3),

$$F_0 = \frac{\Delta E}{\Delta x} = 4 \cdot \pi \cdot R \cdot \sigma$$

Thus, the equation for determining surface tension is

$$\sigma = \frac{F_0}{4 \cdot \pi \cdot R}$$

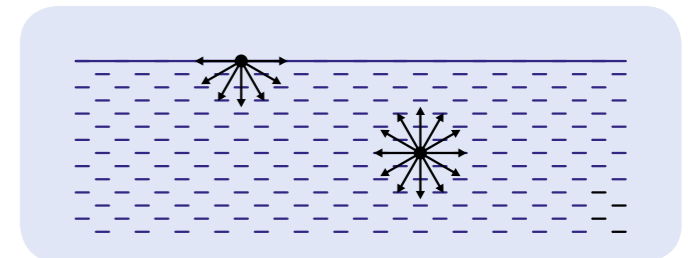

Fig. 1: Interaction forces exerted by neighbouring molecules on a liquid molecule at the surface and a molecule in the interior of the liquid

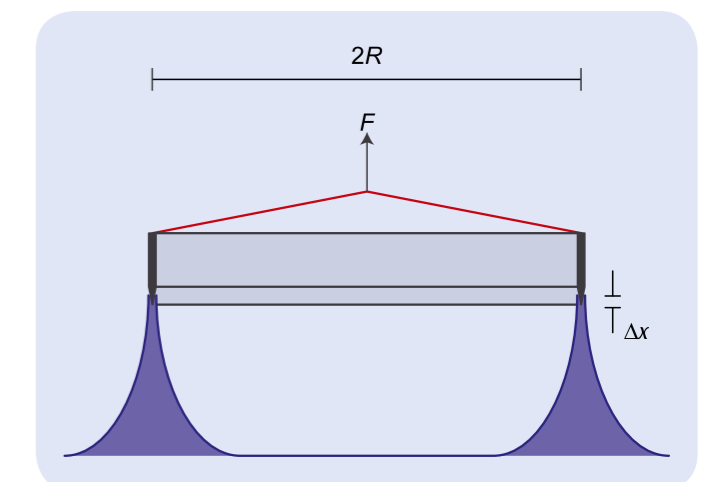

Fig. 2: Schematic diagram



EXPERIMENT PROCEDURE

- Measure thermal expansion in length for tubes made of brass, steel and glass.
- Determine linear expansion coefficients for these materials and compare them with values quoted in literature.

OBJECTIVE

Determine the coefficients of expansion for brass, steel and glass

SUMMARY

If solid bodies are heated up, they generally expand to a greater or lesser degree. In this experiment, hot water is allowed to flow through tubes made of brass, steel and glass. The expansion in their length is measured using a dial gauge. The linear expansion coefficients for the three materials are then calculated from the change in their length.

REQUIRED APPARATUS

Quantity	Description	Number
1	Linear Expansion Apparatus D	1002977
1	Immersion/Circulation Thermostat (230 V, 50/60 Hz)	1008654 or
	Immersion/Circulation Thermostat (115 V, 50/60 Hz)	1008653
1	Gauge with Adapter	1012862
2	Tubing, Silicone 6 mm	1002622

1

NOTE

If it is deemed sufficient to measure the difference in length between room temperature and the temperature of boiling water, a steam generator can be used instead of the circulation thermostat bath. The requisite list of accessories can be found under order number UE2010135 (see Fig. 3).

BASIC PRINCIPLES

In a solid body, each atom vibrates around its equilibrium position. The oscillation is not harmonic because the potential energy is greater when two atoms which have moved from their equilibrium positions happen to get close to one another as opposed to when they are further apart. At higher temperatures, where the oscillation energy is also greater, the atoms vibrate in such a way that the average distance between two neighbouring atoms is greater than the distance between their equilibrium positions. This effect becomes more predominant as the temperature increases, causing the solid body to expand ever more as the temperature rises. It is normal in these circumstances to observe relative changes in length and to calculate the change in volume from this.

The coefficient of linear expansion is defined as:

$$(1) \quad \alpha = \frac{1}{L(\vartheta)} \cdot \frac{dL}{d\vartheta}$$

L : length
 ϑ : temperature in °C

This coefficient depends strongly on the nature of the material and is usually less responsive to the temperature. This leads to the following conclusion:

$$(2) \quad L(\vartheta) = L_0 \cdot \exp(\alpha \cdot \vartheta)$$

$$L_0 = L(0 \text{ °C})$$

If the temperature is not very high:

$$(3) \quad L(\vartheta) = L_0 \cdot (1 + \alpha \cdot \vartheta)$$

In this experiment measurements are carried out on thin tubes made of brass, steel and glass, through which hot water is passed in order to increase their temperature. A circulation thermostat is used to ensure that the water temperature can be adjusted to a constant value. Since one end of the tubes will be fixed in the expansion apparatus, a dial gauge can be used to read off the increase in length at the other end, using room temperature as the reference temperature.

EVALUATION

In the temperature range under investigation $\alpha \cdot \vartheta \ll 1$. Equation (3) can therefore be modified

$$\Delta L = L(\vartheta_1) \cdot \alpha \cdot \Delta\vartheta \quad \text{where } \Delta\vartheta = \vartheta_2 - \vartheta_1, L(\vartheta_1) = 600 \text{ mm}$$

The linear expansion coefficients we are seeking can therefore be determined from the gradient of the straight lines through the origin, as shown in Fig. 1.

The derivation of equation (3) breaks down, though, when higher temperatures are observed, since α proves to be no longer constant, instead being dependent on the temperature. Indeed, strictly speaking that is also the case at the temperatures we are observing. Since the measurement of the linear expansion is measured to an accuracy of 0.01 mm, precise analysis shows that the measurements are not exactly linear, especially for brass, and that the linear expansion coefficients increase slightly with temperature.

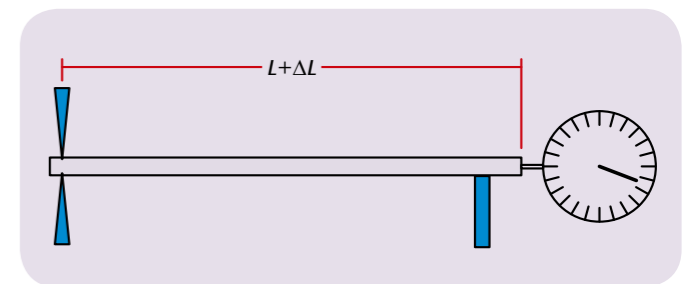

Fig. 1: Schematic of the set-up for the measurements

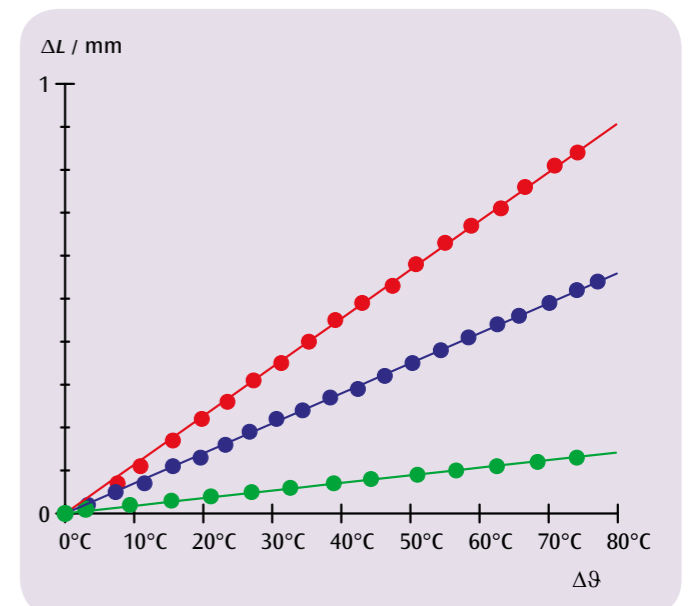
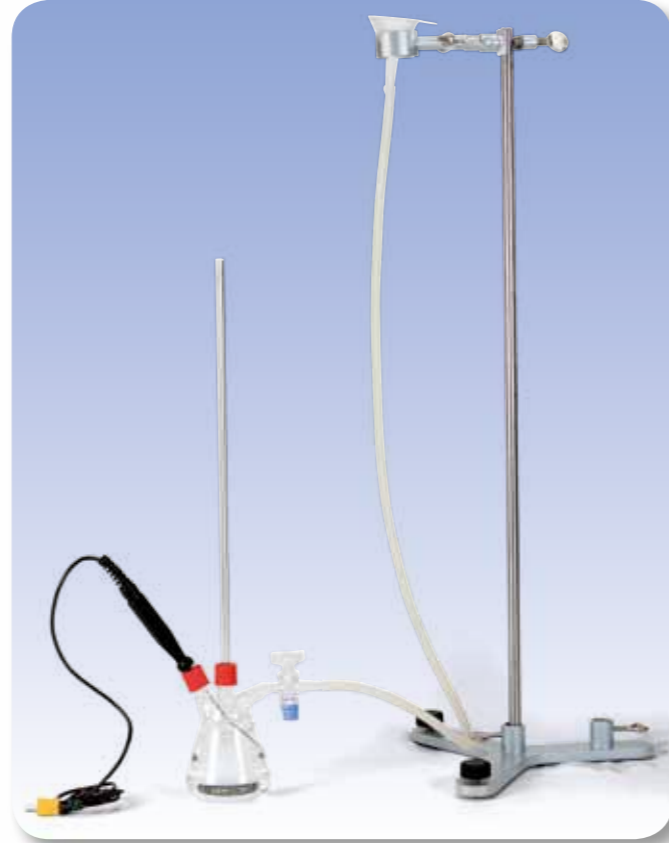

Fig. 2: Change in length of brass (red), steel (blue) and glass (green) as a function of the difference in temperature



Fig. 3: Set-up with steam generator



EXPERIMENT PROCEDURE

- Measure the thermal expansion of water over a temperature range between 0°C and 15°C.
- Demonstrate the thermal anomaly.
- Determine the temperature when the density is at a maximum.

OBJECTIVE

Determine the temperature where water reaches its maximum density

SUMMARY

When temperature is raised from 0°C to about 4°C the volume of a mass of water initially becomes smaller and only begins to expand thermally at higher temperatures. The density of water is therefore at its greatest at around 4°C.

REQUIRED APPARATUS

Quantity	Description	Number
1	Device for Demonstrating the Anomaly of Water	1002889
1	Plastic Trough	4000036
1	Magnetic Stirrer	1002808
1	Digital Thermometer, 1 Channel	1002793
1	K-Type NiCr-Ni Immersion Sensor, -65°C – 550°C	1002804
Additionally recommended:		
1	Funnel	1003568
1	Tubing, Silicone 6 mm	1002622
1	Stainless Steel Rod 470 mm	1002934
1	Clamp with Jaw Clamp	1002829
1	Tripod Stand 150 mm	1002835

1

BASIC PRINCIPLES

Water is unlike most other materials in that up to a temperature of about 4°C it initially contracts and only starts expanding at higher temperatures. Since the density is inversely related to the volume of a mass, water thus reaches its maximum density at about 4°C.

The experiment involves measuring the expansion of water in a vessel with a riser tube. The height h to which water rises up the tube is measured as a function of the water temperature ϑ . Neglecting the fact that the glass vessel also expands at higher temperatures, the total volume of the water in the vessel and in the tube is given by:

$$(1) \quad V(\vartheta) = V_0 + \pi \cdot \frac{d^2}{4} \cdot h(\vartheta)$$

d : Internal diameter of tube, V_0 : Volume of vessel

If the expansion of the vessel is taken into account, equation (1) becomes

$$(2) \quad V(\vartheta) = V_0 \cdot (1 + 3 \cdot \alpha \cdot \vartheta) + \pi \cdot \frac{d^2}{4} \cdot h(\vartheta)$$

$\alpha = 3.3 \cdot 10^{-6} \text{ K}^{-1}$: Linear expansion coefficient of glass

EVALUATION

Water density ρ is derived from equations (1) and (2) as follows:

$$\frac{\rho(\vartheta)}{\rho(0^\circ\text{C})} = \frac{V_0 + \pi \cdot \frac{d^2}{4} \cdot h(0^\circ\text{C})}{V_0 \cdot (1 + 3 \cdot \alpha \cdot \vartheta) + \pi \cdot \frac{d^2}{4} \cdot h(\vartheta)}$$

The maximum for this expression is at $\vartheta = 3.9^\circ\text{C}$.

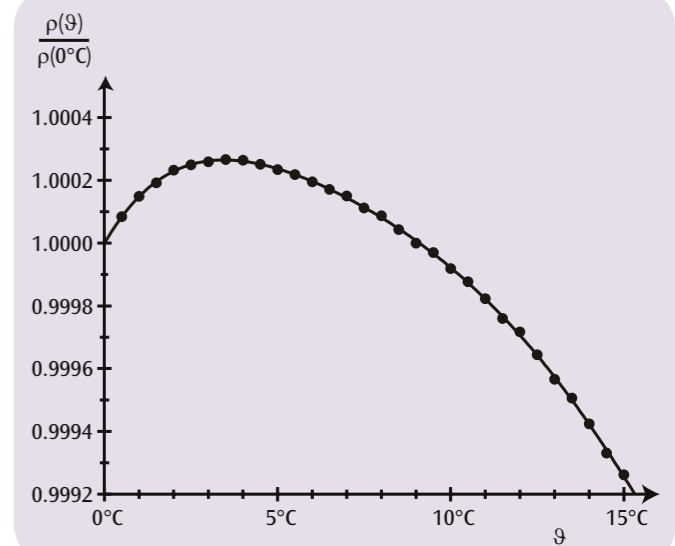

Fig. 1: Relative density of water as a function of temperature

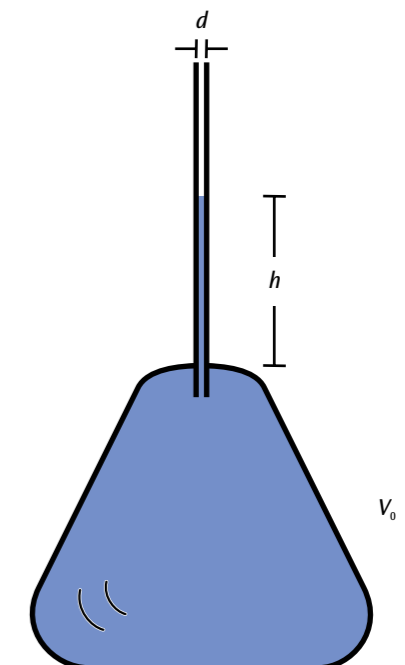

Fig. 2: Vessel with riser tube

OBJECTIVE

Measure conduction of heat in metal bars

EXPERIMENT PROCEDURE

- Measure how temperature changes with time along metal bars which are heated at one end but remain cool at the other in both dynamic and steady states.
- Measure the flow of heat in the steady state.
- Determine the heat conductivity of the material from which the bar is made.

SUMMARY

Conduction of heat involves heat being transferred from a hotter part of an object to a colder area by means of the interaction between neighbouring atoms or molecules, although the atoms themselves remain in place. In a cylindrical metal bar with ends maintained at different temperatures, a temperature gradient will emerge along the bar after a while. The temperature decreases uniformly from the warm end to the cold end and a constant flow of heat arises through the bar. The way the situation changes from a dynamic state to a steady state is observed by means of repeated measurements to determine the temperatures at various measurement points. The metal bars are electrically heated so that the flow of heat in the steady state can be determined from the electrical power supplied.

REQUIRED APPARATUS

Quantity	Description	Number
1	Heat Conduction Equipment Set	1017329
1	Heat Conducting Rod Al	1017331
1	Heat Conducting Rod Cu	1017330
1	DC Power Supply 0 – 20 V, 0 – 5 A (230 V, 50/60 Hz)	1003312 or
	DC Power Supply 0 – 20 V, 0 – 5 A (115 V, 50/60 Hz)	1003311
1	Digital Quick Response Pocket Thermometer	1002803
1	K-Type NiCr-Ni Immersion Sensor, -65°C – 550°C	1002804
1	Pair of Safety Experimental Leads, 75cm, red/blue	1017718
1	Set of 10 Beakers, Low Form	1002872

1

BASIC PRINCIPLES

Heat can be transported from a hotter area to a colder one by conduction, radiation or convection. Conduction of heat involves heat being transferred from a hotter part of an object to a colder area by means of the interaction between neighbouring atoms or molecules, although the atoms themselves remain in place. For instance, when a metal bar is heated, the atoms at the hotter end vibrate more vigorously than those at the cooler end, i.e. they vibrate with more energy. Energy is transferred due to collisions between neighbouring atoms, passing the energy from one atom to another and thereby conducting it along the bar. Metals are particularly good conductors of heat since collisions also occur between atoms and free electrons.

In a bar with a cross-sectional area of A , when the ends are maintained at different temperatures, after a while a temperature gradient emerges along the bar, whereby the temperature decreases uniformly along the length towards the cold end. In a time period dt a quantity of heat dQ flows through the cross-section of the bar and there arises a constant flow of heat P_Q :

$$(1) \quad P_Q = \frac{dQ}{dt} = \lambda \cdot A \cdot \frac{dT}{dx}$$

 P_Q : Flow of heat (measured in watts)

 A : Cross-sectional area of bar

 λ : Heat conductivity of material from which the bar is made

 T : Temperature, x : Coordinate of length along the bar

Before the constant temperature gradient arises, the temperature distribution at a specific time t is given by $T(x,t)$, which gradually becomes closer to the steady state. The following differential equation then applies

$$(2) \quad \lambda \cdot \frac{\partial^2 T}{\partial x^2}(x,t) - c \cdot \rho \cdot \frac{\partial T}{\partial t}(x,t) = 0$$

 c : Specific heat capacity

 ρ : Density of material from which bar is made

In the steady state the situation is in agreement with equation (1)

$$(3) \quad \frac{\partial T}{\partial t}(x,t) = 0 \quad \text{and} \quad \lambda \cdot \frac{\partial T}{\partial x}(x,t) = \text{const.} = \frac{P_Q}{A}$$

In this experiment the bar is heated at one end by electrical means. An electronically regulated source of heat provides the bar with an amount of heat which can be determined by measuring the heater voltage U and current I :

$$(4) \quad P_{el} = U \cdot I$$

Electronic regulation of the current ensures that this end of the bar rapidly reaches a temperature of about 90°C and this temperature is then maintained constant.

The other end of the bar is kept at the temperature of melting ice or simply water at room temperature via its cooling baffles. This allows the heating to be determined by calorimetry.

An insulating sleeve minimises the loss of heat from the bar to its surroundings and ensures the temperature profile is more linear in the steady state. Using an electronic thermometer that determines temperature within a second, temperatures are measured at pre-defined measurement points along the bar. Both a copper bar and an aluminium bar are provided.

EVALUATION

The flow of heat P_Q corresponds to the electrical power P_{el} minus a small quantity of power dissipated due to losses P_l : $P_Q = P_{el} - P_l$

$$\text{Therefore:} \quad \lambda = \frac{P_{el} - P_l}{A} \cdot \frac{L}{T(0) - T(L)}$$

(L : Distance between selected temperature measurement points)

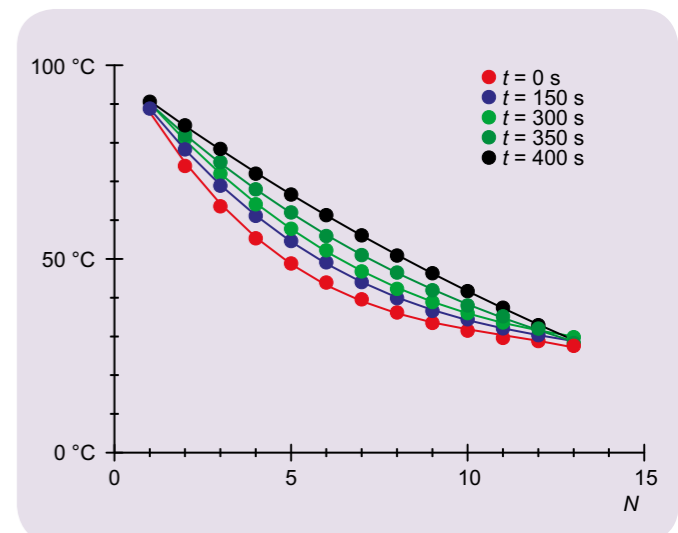

Fig. 1: Temperatures along the aluminium rod in five sets of measurements made at time intervals of 150 s



EXPERIMENT PROCEDURE

- Detect radiation from a Leslie cube with a Moll thermopile.
- Measure intensity of heat radiated by four different surfaces in relation to one another as a function of temperature.
- Confirm that the radiation intensities are proportional to T^4 .

OBJECTIVE

Measure the heat radiated by a Leslie cube

SUMMARY

The radiation emitted by a body depends on its temperature and the nature of its surface. More specifically, according to Kirchhoff's law, the ratio between emissivity and absorptivity is identical for all bodies at a given temperature and corresponds to emissivity of a black body E_{SB} at this temperature. In this experiment, we will heat a Leslie cube by filling it with water to a temperature of 100°C and ascertain the radiated intensity in a relative measurement using a Moll thermopile.

REQUIRED APPARATUS

Quantity	Description	Number
1	Leslie's Cube	1000835
1	Rotating base for Leslie cube	1017875
1	Moll-Type Thermopile	1000824
1	Measurement Amplifier (230 V, 50/60 Hz)	1001022 or
	Measurement Amplifier (115 V, 50/60 Hz)	1001021
1	Digital Multimeter P3340	1002785
1	Digital Quick Response Pocket Thermometer	1002803
1	K-Type NiCr-Ni Immersion Sensor, $-65^\circ\text{C} - 550^\circ\text{C}$	1002804
1	Pair of Safety Experiment Leads, 75 cm	1002849
1	HF Patch Cord, BNC/4 mm Plug	1002748
2	Barrel Foot, 500 g	1001046
1	Pocket Measuring Tape, 2 m	1002603

1

BASIC PRINCIPLES

Heat is exchanged between a body and its surroundings by the emission and absorption of heat radiation. The radiation depends on the body's temperature and the nature of its surface, as can be demonstrated by means of a Leslie cube.

The emitted intensity is described by the body's emissivity E . The absorptivity A is the ratio between absorbed and incident radiation intensity. It turns out that absorptivity increases with emissivity. More specifically, according to Kirchhoff's law, the ratio between emissivity and absorptivity is identical for all bodies at a given temperature, and corresponds to emissivity of a black body E_{SB} at this temperature:

$$(1) \quad \frac{E(T)}{A} = E_{SB}(T) = \sigma \cdot T^4$$

σ : Stefan-Boltzmann constant

T : Temperature in Kelvin

The degree to which absorptivity depends on temperature is generally negligible. Therefore the emissivity of a body can be described as follows:

$$(2) \quad E(T) = A \cdot \sigma \cdot T^4$$

If the body has the same temperature T_0 as its surroundings, the intensity of the heat radiated by the body into the surroundings is equal to that of the heat it absorbs from them:

$$(3) \quad E(T_0) = A \cdot \sigma \cdot T_0^4$$

If the body's temperature is higher, the intensity of the radiation absorbed from the surroundings does not change as long as the ambient temperature remains constant. Therefore, the energy radiated by a body per unit of surface and time and measurable by means of a radiation detector is as follows:

$$(4) \quad \Delta E(T) = A \cdot \sigma \cdot (T^4 - T_0^4)$$

In this experiment, a Leslie cube equipped with one white, one black, one matt and one shiny surface is heated by filling it with water boiled to a temperature of 100°C . The radiated intensity is then ascertained by means of a relative measurement using a Moll thermopile. The measured values for the four different surfaces are monitored during the entire process of cooling to room temperature.

EVALUATION

Plotting the readings against the quantity $x = T^4 - T_0^4$ results in four lines which pass through the origin and have slopes corresponding to the respective absorptivities of the surfaces.

In the investigated temperature range up to 100°C , there is no great difference between the black and white surfaces or between the matte and glossy surfaces, even though the visual distinction is clear. Obviously, the surfaces do not differ significantly in the infra-red wavelength range.

1: White surface. 2: Black surface. 3: Matt surface. 4: Shiny surface.

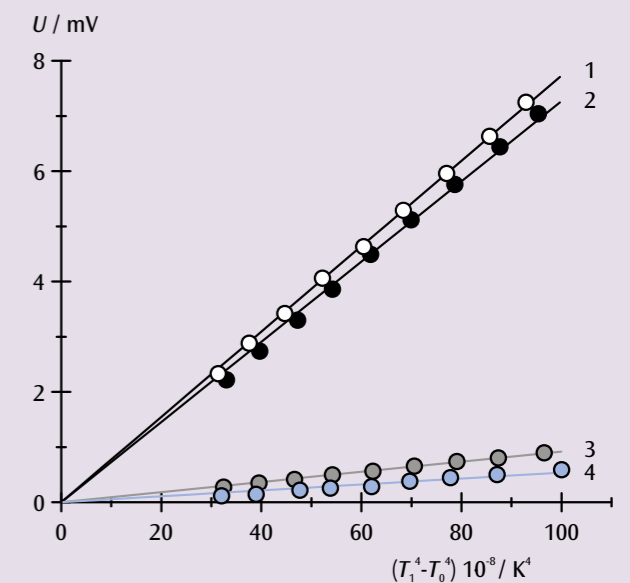

Fig 1: Radiated intensity from a Leslie cube as a function of $x = T^4 - T_0^4$



EXPERIMENT PROCEDURE

- Measuring the temperature of the aluminium body as a function of the number of rotations against the friction cord.
- Investigating the proportionality between the temperature change and the frictional work, and thereby verifying the First Law of Thermodynamics.
- Determining the specific heat capacity of aluminium.

OBJECTIVE

Verifying the First Law of Thermodynamics

SUMMARY

The experiment is to investigate the increase of internal energy of an aluminium body caused by friction. The increase can be observed by measuring the increase in the temperature of the body, which is proportional to the work done, as the body undergoes no change in the state of aggregation and no chemical reaction occurs. To eliminate the effect of heat exchange between the aluminium body and the environment as far as possible, begin the series of measurements slightly below room temperature and end the series at a temperature slightly above room temperature. The difference below and above room temperature prior to starting the measurements and at the point of concluding them should approximately be the same.

REQUIRED APPARATUS

Quantity	Description	Number
1	Heat Equivalent Apparatus	1002658
1	Digital Multimeter P1035	1002781
1	Pair of Safety Experiment Leads, 75 cm	1017718

1

BASIC PRINCIPLES

According to the First Law of Thermodynamics, the change of the internal energy of a system ΔE is equal to the sum of the work performed ΔW and the transferred heat ΔQ . It can be measured as the proportional change in the temperature of the system ΔT , provided that there is no change in the state of aggregation and that no chemical reaction occurs.

The experiment is conducted to investigate the increase in the internal energy of an aluminium body caused by mechanical work. The cylindrical body is rotated about its axis by means of a hand-operated crank. A cord running over the curved surface provides the friction to heat the body. The frictional force F corresponds to the weight of a mass that is suspended from the end of the friction cord. The suspended mass is balanced by the frictional force. Therefore, the work performed against friction during n revolutions of the body is

$$(1) \quad \Delta W_n = F \cdot \pi \cdot d \cdot n$$

d : Diameter of the cylindrical body.

During the n revolutions, the frictional work raises the temperature of the body from the initial value T_0 to the final value T_n . At the same time the internal energy is increased by

$$(2) \quad \Delta E_n = m \cdot c_{Al} \cdot (T_n - T_0)$$

m : Mass of the body
 c_{Al} : Specific heat capacity of aluminium.

To avoid a net exchange of heat with the environment as far as possible, the body is cooled, before starting the measurement, to an initial temperature T_0 that is only slightly below room temperature. The measurement is concluded as soon as the body reaches a final temperature T_n that is slightly above room temperature.

Note: The difference below and above room temperature prior to starting the measurements and at the point of concluding them should approximately be the same.

This ensures that the conversion of internal energy matches the work done. Thus, we have the following relation:

$$(3) \quad \Delta E_n = \Delta W_n$$

EVALUATION

From Equations 2 and 3, we derive the relation

$$T_n = T_0 + \frac{1}{m \cdot c_{Al}} \cdot \Delta W_n$$

It is therefore necessary to plot the measured final temperatures T_n as functions of the work performed W_n on a graph (see Fig. 1). The values measured in the vicinity of room temperature lie on a straight line. It is possible to determine the specific heat capacity of aluminium from its gradient. In the region below room temperature, the measured temperatures rise faster than would correspond to the gradient of the straight line, as the aluminium body absorbs heat from the surroundings. Conversely, in the region above room temperature heat is lost to the surroundings.

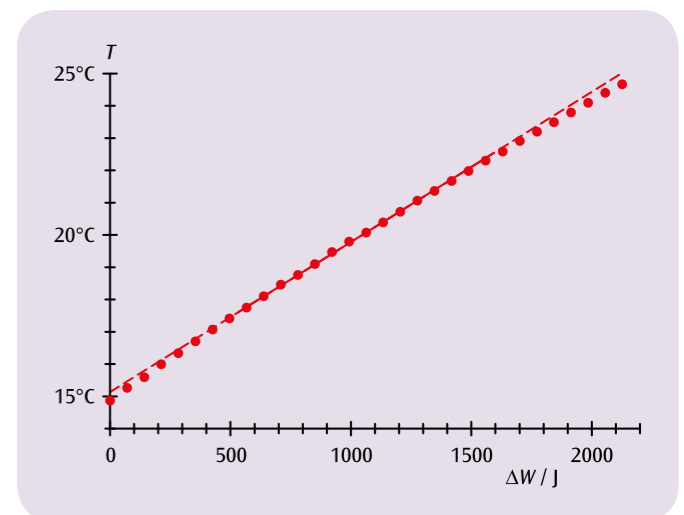

Fig. 1: The temperature of the aluminium body as a function of work performed against friction



EXPERIMENT PROCEDURE

- Measure the temperature of aluminium and copper calorimeters as a function of the electrical work done.
- Check that the change in temperature is proportional to the electrical work and verify the first law of thermodynamics.
- Determine the specific heat capacities of copper and aluminium.

OBJECTIVE

Increase internal energy by means of electrical work

SUMMARY

This experiment investigates how the internal energy of copper and aluminium calorimeters can be increased by electrical work. As long as the aggregate state does not change and no chemical reactions occur, it is possible to determine the increase in internal energy from the rise in temperature to which it is proportional. In order to prevent heat being transferred from the calorimeters to their surroundings, the series of measurements should start at a temperature somewhat below the ambient temperature and finish at a temperature only slightly above that of the surroundings.

REQUIRED APPARATUS

Quantity	Description	Number
1	Copper Calorimeter	1002659
1	Aluminium calorimeter	1017897
1	Temperature sensor	1017898
1	Pair of adapter cables with 4 mm safety plugs/2 mm plugs	1017899
1	Pair of Safety Experimental Leads, 75cm, red/blue	1017718
1	Digital Multimeter P1035	1002781
1	DC Power Supply 0 – 20 V, 0 – 5 A (230 V, 50/60 Hz)	1003312 or
	DC Power Supply 0 – 20 V, 0 – 5 A (115 V, 50/60 Hz)	1003311

1

BASIC PRINCIPLES

The internal energy of a system can be increased not only by mechanical work but also by electrical work. In both cases, the temperature of the system rises in linear proportion to the work done, as long as there is no change in the aggregate state and no chemical reactions occur.

This experiment investigates how the internal energy of copper and aluminium calorimeters is increased by electrical work. This is proportional to the applied voltage U , the current I which flows and the time the measurement is made t :

$$(1) \quad \Delta W_{\text{el}}(t) = U \cdot I \cdot t$$

This electrical work causes the temperature of the calorimeter to rise from an initial value T_0 to a final value T_n . Therefore the internal energy rises by the following amount:

$$(2) \quad \Delta E(t) = m \cdot c \cdot (T(t) - T_0)$$

m : mass of calorimeter
 c : specific heat capacity of material

In order to minimise transfer of heat to the surroundings as far as possible, the calorimeter is initially cooled down to a start temperature of T_0 before any measurements are made. This should be only slightly lower than the ambient temperature. Measurement is halted when a final temperature T_n is attained, which is equally as far above the ambient temperature as the initial temperature was below it.

Under such conditions, the change in internal energy should be equal to the work done, meaning that the following applies:

$$(3) \quad \Delta E(t) = \Delta W_{\text{el}}(t)$$

EVALUATION

An NTC temperature sensor is used to measure the temperature T by measuring its resistance, which depends on the temperature. The following applies

$$T = \frac{217}{R^{0.13}} - 151$$

The temperatures measured in this way are plotted against the electrical work. The heat capacity of the calorimeters can be determined from the slope of straight lines in the graphs and as long as their mass is known, it is then possible to calculate the specific heat capacity.

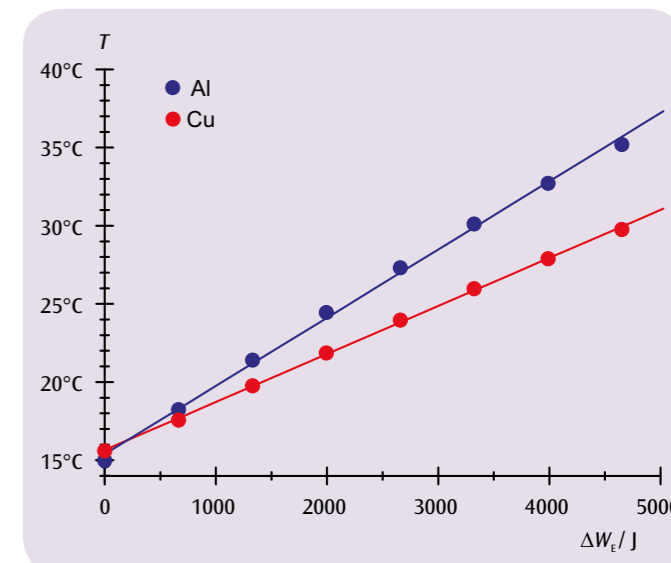

Fig. 1: Calorimeter temperature as a function of electrical work

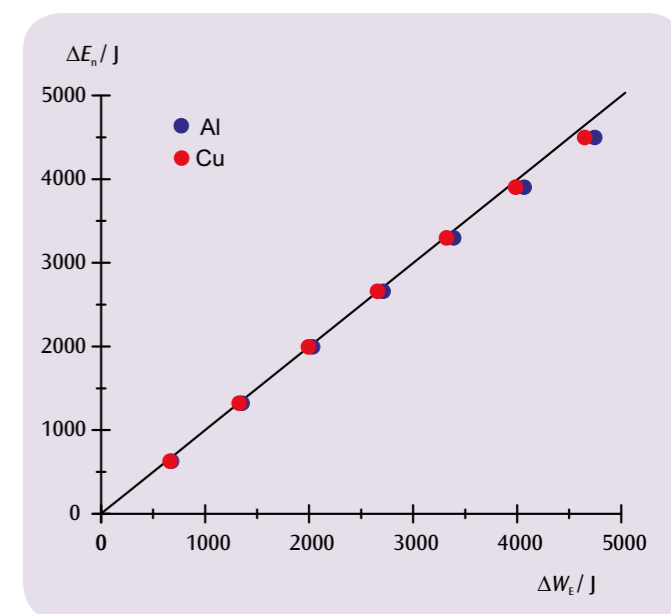
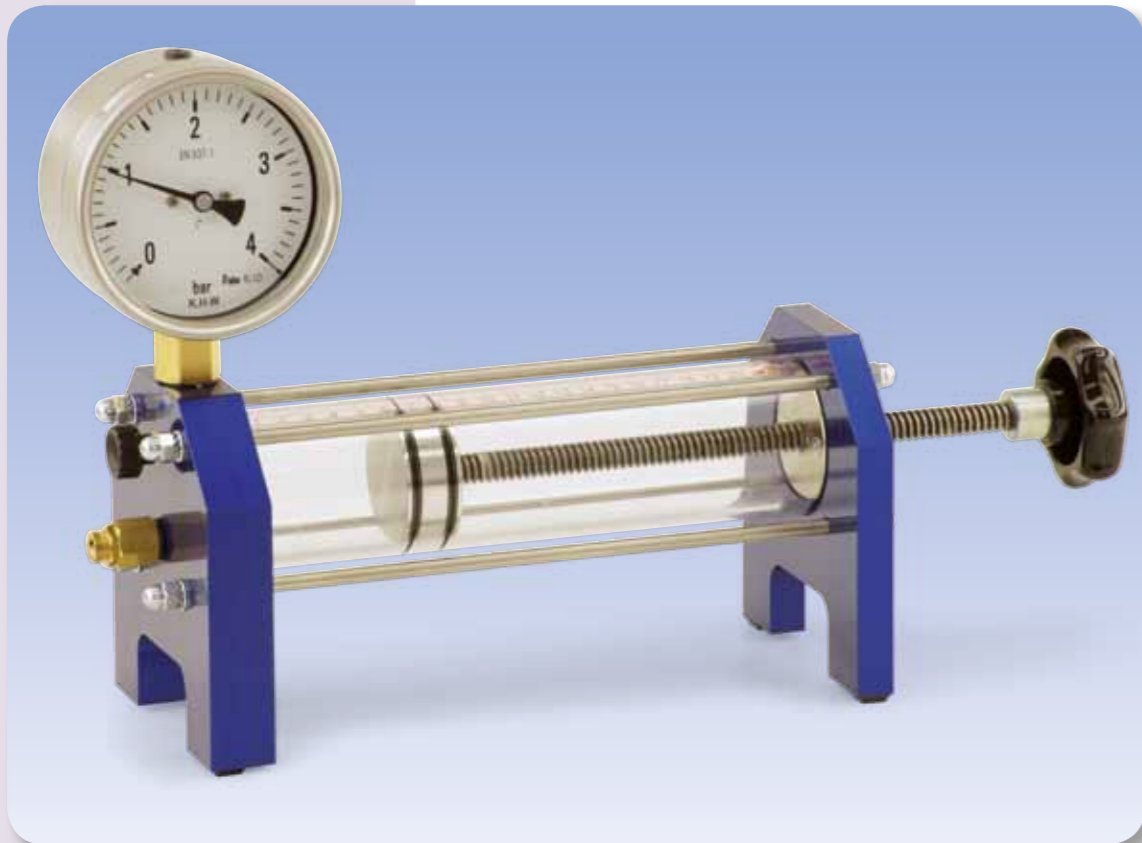

Fig. 2: Change in internal energy as a function of electrical work done



EXPERIMENT PROCEDURE

- Measuring the pressure p of the enclosed air at room temperature for different positions s of the piston.
- Displaying the measured values for three different quantities of air in the form of a p - V diagram.
- Verifying Boyle's Law.

OBJECTIVE

Measurement at room temperature in air as an ideal gas

SUMMARY

The experiment verifies Boyle's Law for ideal gases at room temperature, taking air as an ideal gas in this experiment. The volume of a cylindrical vessel is varied by the movement of a piston, while simultaneously measuring the pressure of the enclosed air.

REQUIRED APPARATUS

Quantity	Description	Number
1	Boyle's Law Apparatus	1017366

1

BASIC PRINCIPLES

The volume of a fixed quantity of a gas depends on the pressure acting on the gas and on the temperature of the gas. If the temperature remains unchanged, the product of the volume and the temperature remains constant in many cases. This law, discovered by Robert Boyle and Edme Mariotte, is valid for all gases in the ideal state, which is when the temperature of the gas is far above the point that is called its critical temperature.

The law discovered by Boyle and Mariotte states that:

$$(1) \quad p \cdot V = \text{const.}$$

and is a special case of the more general law that applies to all ideal gases. This general law describes the relationship between the pressure p , the volume V , the temperature T referred to absolute zero, and the quantity n of the gas:

$$(2) \quad p \cdot V = n \cdot R \cdot T$$

$$R = 8.314 \frac{\text{J}}{\text{mol} \cdot \text{K}} \quad (\text{the universal gas constant}).$$

From the general equation (2), the special case (1) is derived given the condition that the temperature T and the quantity of the gas n do not change.

In the experiment, the validity of Boyle's Law at room temperature is demonstrated by taking air as an ideal gas. The volume V of air in a cylindrical vessel is varied by the movement of a piston, while simultaneously measuring the pressure p of the enclosed air.

The quantity n of the gas depends on the initial volume V_0 into which the air is admitted through an open valve before starting the experiment.

EVALUATION

As the cross-sectional area A of the piston is constant, the volume V of the enclosed air can easily be calculated from the distance s travelled by the piston relative to the zero-volume position. For an exact analysis, the unavoidable dead volume V_1 of the air in the manometer should also be taken into account.

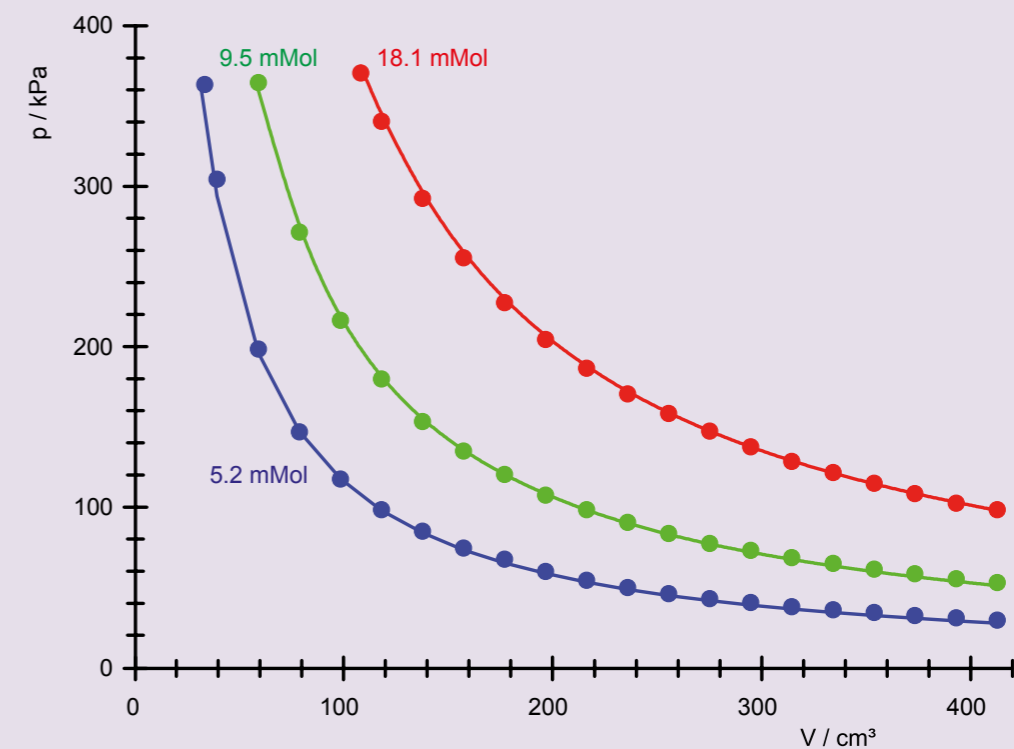

Fig. 1: Pressure/volume diagrams for three different quantities of air at room temperature



OBJECTIVE

Determine the adiabatic index C_p/C_v for air using Rüchardt's method

SUMMARY

In this experiment an aluminium piston inside a precision-manufactured glass tube extending vertically from on top of a glass vessel undergoes simple harmonic motion on top of the cushion formed by the volume of air trapped inside the tube. From the period of oscillation of the piston, it is possible to calculate the adiabatic index.

EXPERIMENT PROCEDURE

- Measure the period of oscillation of the aluminium piston.
- Determine the equilibrium pressure within the enclosed volume of air.
- Determine the adiabatic index of air and compare your result with the value quoted in literature.

2

REQUIRED APPARATUS

Quantity	Description	Number
1	Mariotte Flask	1002894
1	Oscillation Tube	1002895
1	Mechanical Stopwatch, 15 min	1003369
1	Vacuum Hand Pump	1012856
Additionally recommended:		
1	Aneroid Barometer F	1010232
1	Callipers, 150 mm	1002601
1	Electronic Scale 200 g	1003433

BASIC PRINCIPLES

In a classic experiment designed by Rüchardt, it is possible to determine the adiabatic index for air from the vertical oscillations of a piston resting on a cushion of air inside a glass tube of constant cross-sectional area. The piston itself fits snugly and forms an air-tight seal. Disturbing the piston from its equilibrium position causes the air inside the tube to become expanded or compressed, causing the pressure inside to rise above or below atmospheric pressure, the effect of which is to restore the piston to its equilibrium position. The restoring force is proportional to the deviation from the equilibrium position, meaning that the piston exhibits simple harmonic oscillation.

Since there is no exchange of heat with the surroundings, the oscillations are associated with adiabatic changes of state. The following equation describes the relationship between the pressure p and the volume V of the enclosed air:

$$(1) \quad p \cdot V^\gamma = \text{const.}$$

The adiabatic index γ is the ratio between the specific heat capacity at constant pressure C_p and constant volume C_v :

$$(2) \quad \gamma = \frac{C_p}{C_v}$$

From equation (1), the following relationship can be derived for changes in pressure and volume Δp and ΔV

$$(3) \quad \Delta p + \gamma \cdot \frac{p}{V} \cdot \Delta V = 0.$$

By substituting the internal cross-sectional area A of the tube, the restoring force ΔF can be calculated from the change in pressure. Similarly the deflection of the piston from its equilibrium position can be determined from the change in volume.

Therefore, the following applies:

$$(4) \quad \Delta F = -\gamma \cdot \frac{p}{V} \cdot A^2 \cdot \Delta s = 0.$$

This leads to the equation of motion for the oscillating piston.

$$(5) \quad m \cdot \frac{d^2 \Delta s}{dt^2} + \gamma \cdot \frac{p}{V} \cdot A^2 \cdot \Delta s = 0$$

$m = \text{Mass of piston}$

Solutions to this classical equation of motion for simple harmonic oscillators are oscillations with the following period:

$$(6) \quad T = 2\pi \sqrt{\frac{1}{\gamma} \cdot \frac{V}{p} \cdot \frac{m}{A^2}},$$

From this, the adiabatic index can be calculated as long as all the other variables are known.

In this experiment, a precision-made glass tube of small cross section A is set up vertically in a hole through the stopper for a glass vessel of large volume V and a matching aluminium piston of known mass m is allowed to slide up and down inside the tube. The aluminium piston exhibits simple harmonic motion atop the air cushion formed by the enclosed volume. It is possible to calculate the adiabatic index from the period of oscillation of the piston.

EVALUATION

The equilibrium volume V corresponds to the volume of the gas vessel, since that of the tube is small enough to be disregarded.

$$\gamma = \left(\frac{2\pi}{T}\right)^2 \frac{m \cdot V}{A^2 \cdot p}$$

The equilibrium pressure p is obtained from the external air pressure p_0 and the pressure exerted by the aluminium piston on the enclosed air in its rest state:

$$p = p_0 + \frac{m \cdot g}{A}, \text{ where } g = \text{acceleration due to gravity}$$

The expected result is therefore $\gamma = \frac{7}{5} = 1.4$, since air predominantly

consists of diatomic molecules with 5 degrees of freedom for the absorption of heat energy.

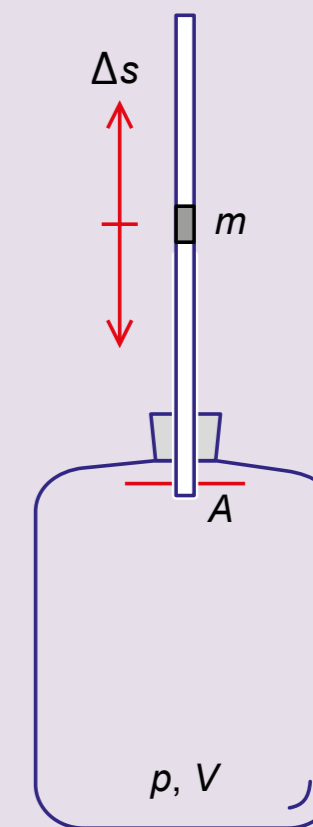
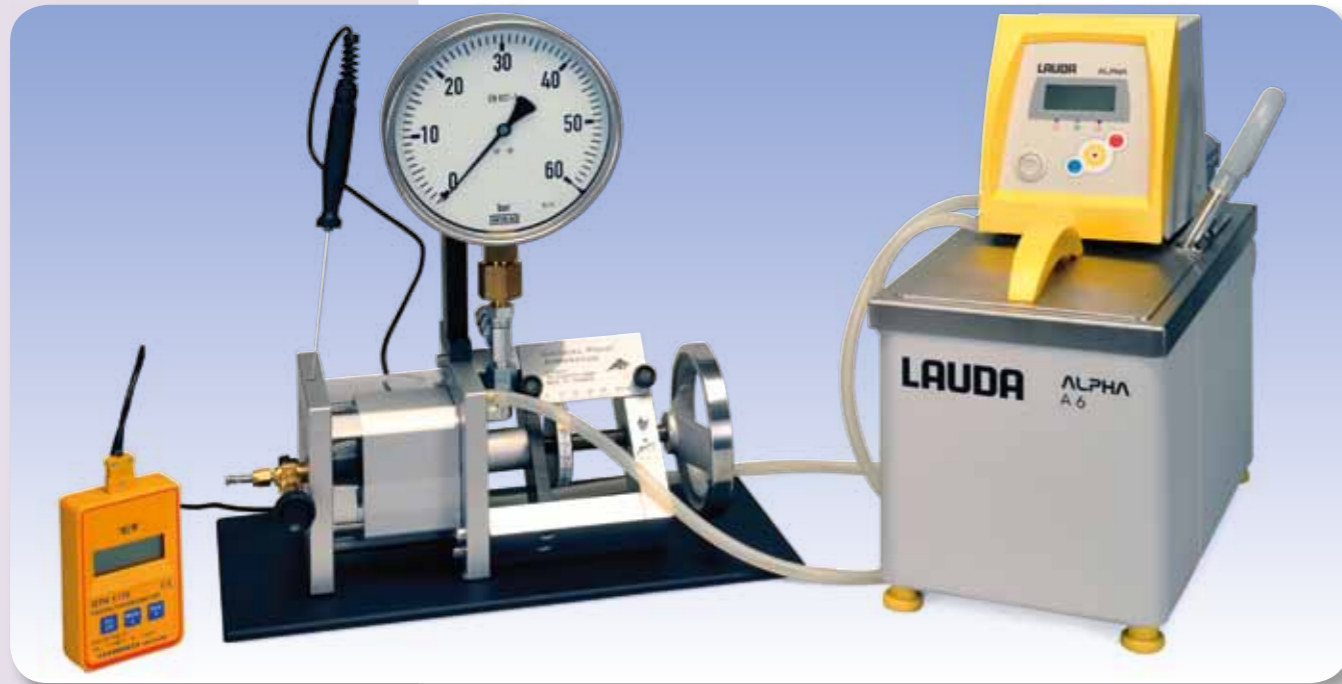

Fig. 1: Schematic of experiment set-up



EXPERIMENT PROCEDURE

- Observing sulphur hexafluoride in both the liquid and gaseous states.
- Plotting isotherms in a p - V diagram and a pV - p diagram.
- Observing how the behaviour of real gases deviates from that for the ideal gas state.
- Determining the critical point.
- Plotting pressure curves for a saturated vapour.

OBJECTIVE

Quantitative analysis of a real gas and determining its critical point

SUMMARY

Sulphur hexafluoride (SF_6) serves as a real gas and is examined in a measurement cell with only a minimal dead volume. Sulphur hexafluoride is especially suitable for this experiment, as its critical temperature ($T_c = 319\text{ K}$) and its critical pressure ($p_c = 37.6\text{ bar}$) are both relatively low. It is also non-toxic and is quite safe for use in teaching and in practical classes.

REQUIRED APPARATUS

Quantity	Description	Number
1	Critical Point Apparatus	1002670
1	Immersion/Circulation Thermostat (230 V; 50/60 Hz)	1008654 or
	Immersion/Circulation Thermostat (115 V; 50/60 Hz)	1008653
1	Digital Quick Response Pocket Thermometer	1002803
1	K-Type NiCr-Ni Immersion Sensor, $-65^\circ\text{C} - 550^\circ\text{C}$	1002804
2	Tubings, Silicone 6 mm	1002622

Additionally required:

Sulphur hexafluoride (SF_6)

3

NOTE

In accordance with the principles of good laboratory practice, it is recommended that the gas connections should be made by rigid metal pipework, especially if the critical point apparatus is to be used regularly. For connecting to an appropriate gas cylinder, use the 1/8" (SW 11) threaded pipe connector that is supplied.

BASIC PRINCIPLES

The critical point of a real gas is characterised by the critical temperature T_c , the critical pressure p_c , and the critical density ρ_c . Below the critical temperature, the substance is gaseous at large volumes and liquid at small volumes. At intermediate volumes it can exist as a liquid-gas mixture, in which changing the volume under isothermal conditions causes a change of state: the gaseous fraction increases as the volume is increased, while the pressure of the mixture remains constant. As the liquid and the vapour have different densities, they are separated by the gravitational field. As the temperature rises, the density of the liquid decreases and that of the gas increases until the two densities converge at the value of the critical density. Above the critical temperature, the gas can no longer be liquefied. However, under isothermal conditions the gas does not obey Boyle's Law until the temperature is raised considerably above the critical temperature.

Sulphur hexafluoride (SF_6) is especially suitable for investigating the properties of real gases, as its critical temperature ($T_c = 319\text{ K}$) and its critical pressure ($p_c = 37.6\text{ bar}$) are both relatively low. It is also non-toxic and is quite safe for use in teaching and in practical classes.

The apparatus for investigating the critical point consists of a transparent measurement cell, which has very thick walls and can withstand high pressures. The internal volume of the cell can be changed by turning a hand-wheel, which allows one to make fine adjustments and can be read with a precision down to 1/1000 of the maximum volume. Pressure is applied by a hydraulic system using castor oil of pharmaceutical quality. The hydraulic system is separated from the cell by a conical rubber seal, which rolls up when the volume is changed. This form of construction ensures that the pressure difference between the measurement cell and the oil space is practically negligible. Therefore, instead of measuring the gas pressure directly, a manometer measures the oil pressure, which avoids having a dead volume in the gas space. The measurement cell is enclosed within a transparent water jacket. During the experiment a thermostatic water bath maintains a precisely controlled and adjustable constant temperature, which is measured by a digital thermometer.

During observations of the transition from the gaseous to the liquid phase and the reverse process, the fact that there is very little dead volume makes it possible to observe the formation of the first drop of liquid or the disappearance of the last bubble of gas.

EVALUATION

The pressure as a function of the volume is measured point-by-point at constant temperature, and the results are plotted as a p - V diagram (Clapeyron diagram) and as a pV - p diagram (Amegat diagram). The deviation from the behaviour of an ideal gas is immediately obvious and striking.

From the diagrams, the parameters of the critical point can easily be determined, and it is possible to obtain a clear experimental verification of the behaviour of a real gas.

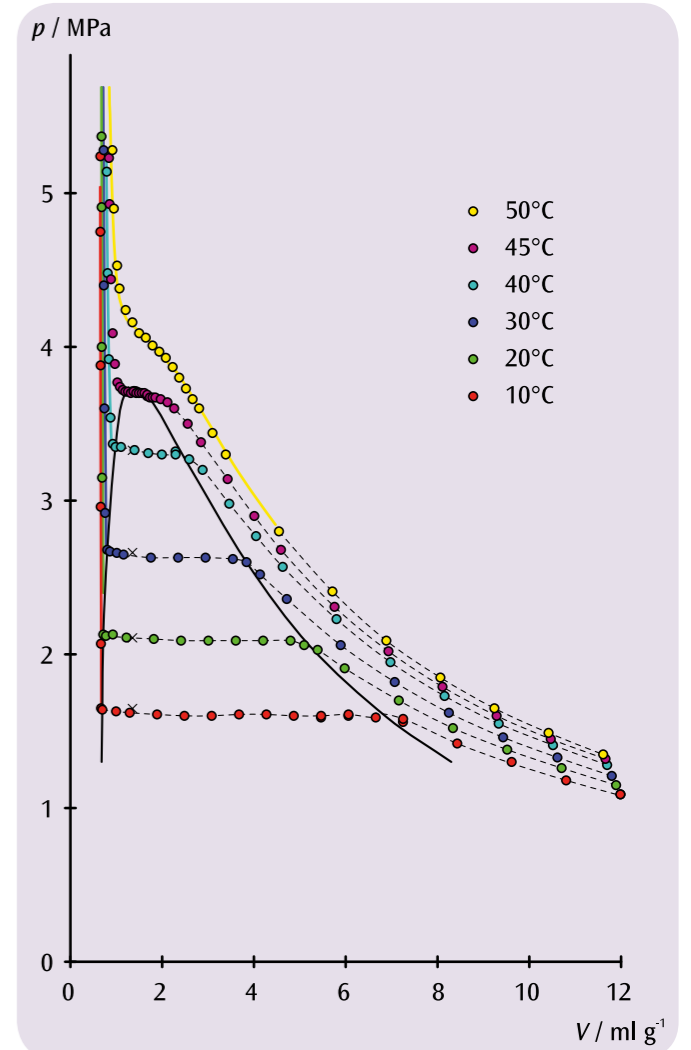

Fig. 1: p - V diagram of sulphur hexafluoride



EXPERIMENT PROCEDURE

- Operate the hot-air engine as a heat engine.
- Demonstrate how thermal energy is converted into mechanical energy.
- Measure the no-load speed as a function of the thermal power.



OBJECTIVE

Operate a functional model of a Stirling engine as a heat engine

SUMMARY

A hot-air engine is a classical example of a heat engine. In the course of a thermodynamic cycle thermal energy is fed in from a high temperature reservoir and then partially converted into useable mechanical energy. The remaining thermal energy is then transferred to a reservoir at a lower temperature.

REQUIRED APPARATUS

Quantity	Description	Number
1	Wilke-Type Stirling Engine	1000817
1	DC Power Supply 0 – 20 V, 0 – 5 A (230 V, 50/60 Hz)	1003312 or
1	DC Power Supply 0 – 20 V, 0 – 5 A (115 V, 50/60 Hz)	1003311
1	Set of 15 Safety Experiment Leads, 75 cm	1017718
1	Mechanical Stopwatch, 30 min	1003369

BASIC PRINCIPLES

The thermodynamic cycle of a hot-air engine (invented by R. Stirling, 1816) can be simplified by breaking the cycle down into the separate processes of heating, expansion, cooling and compression. These processes are depicted schematically in Figs. 1-4 for the functional model under investigation.

If the hot-air engine is operated without any mechanical load, it rotates at its no-load speed, which is restricted by internal friction and is dependent on the amount of thermal energy supplied. The speed drops as soon as the mechanical power is tapped. This can be demonstrated most clearly by applying a frictional force to the crankshaft.

EVALUATION

Heating:

Heat is introduced when the displacement piston extends thereby pushing air into the heated region of the large cylinder. During this operation the working piston is at its bottom dead centre position since the displacement piston is ahead of the working piston by 90°.

Expansion:

The heated air expands and causes the working piston to retract. At the same time mechanical work is transferred to the flywheel rod via the crankshaft.

Cooling:

While the working piston is in its top dead centre position: the displacement piston retracts and air is displaced towards the top end of the large cylinder so that it cools.

Compression:

The cooled air is compressed by the working piston extending. The mechanical work required for this is provided by the flywheel rod.

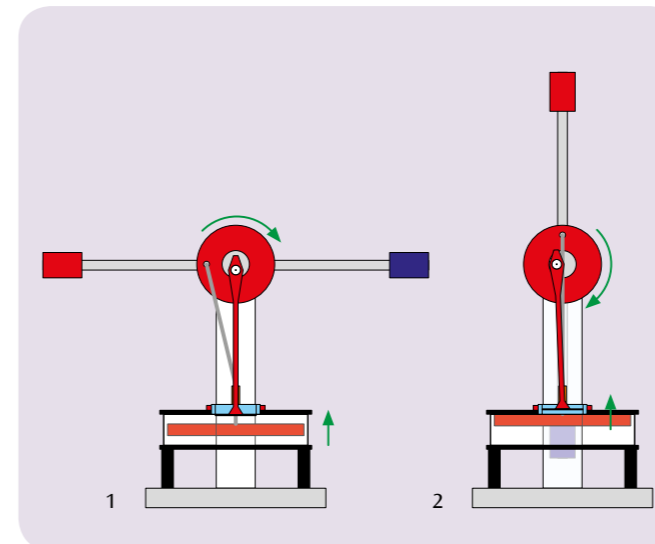

Fig. 1: Heating
Fig. 2: Expansion

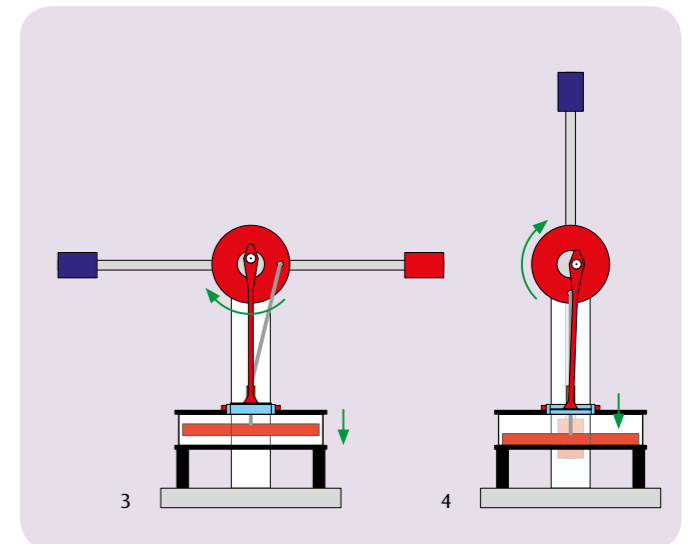

Fig. 3: Cooling
Fig. 4: Compression



EXPERIMENT PROCEDURE

- Record a p - V diagram.
- Determine the mechanical power associated with a full cycle and calculate the mechanical work.

OBJECTIVE

Record a p - V diagram.

SUMMARY

Cyclic processes in thermodynamics can be plotted as a closed loop in a p - V diagram. The area enclosed by the curve corresponds to the mechanical work taken from the system. Alternatively, the mechanical power associated with a complete cycle can be determined and then the mechanical work can be calculated from that by means of an integration over time. This will be investigated in the course of an experiment using a Stirling engine.

REQUIRED APPARATUS

Quantity	Description	Number
1	Stirling Engine G	1002594
1	Sensor Holder for Stirling Engine G	1008500
1	Displacement Sensor	1000568
1	Relative Pressure Sensor, ± 1000 hPa	1000548
1	3B NETlab™	1000544
1	3B NETlog™ (230 V, 50/60 Hz)	1000540 or
1	3B NETlog™ (115 V, 50/60 Hz)	1000539
1	DC Power Supply 0 – 20 V, 0 – 5 A (230 V, 50/60 Hz)	1003312 or
1	DC Power Supply 0 – 20 V, 0 – 5 A (115 V, 50/60 Hz)	1003311
1	Pair of Safety Experimental Leads, 75cm, red/blue	1017718

2

BASIC PRINCIPLES

Cyclic processes in thermodynamics can be plotted as a closed loop in a p - V diagram. The area enclosed by the curve corresponds to the mechanical work W taken from the system. Alternatively, the mechanical power P associated with a complete cycle can be determined and then the mechanical work can be calculated from that by means of an integration over time.

The following equations apply:

$$(1) \quad W = \oint p dV$$

or

$$(2) \quad W = \int_{t_1}^{t_2} P dt \quad \text{with} \quad P(t) = p \frac{dV}{dt}$$

For the experiment we will choose the second variant to determine the mechanical power output in each cycle by a glass Stirling engine specifically designed for educational purposes. To determine the pressure p in the main cylinder, a relative pressure sensor is fitted, which measures the difference in cylinder pressure from the ambient pressure. The volume V is calculated from the distance s travelled by the main piston and its cross-sectional area A . A displacement sensor is attached to the main piston for this purpose.

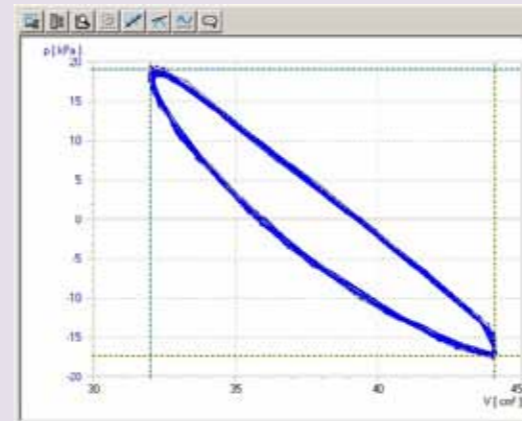

Fig. 1: p - V diagram for Stirling engine G

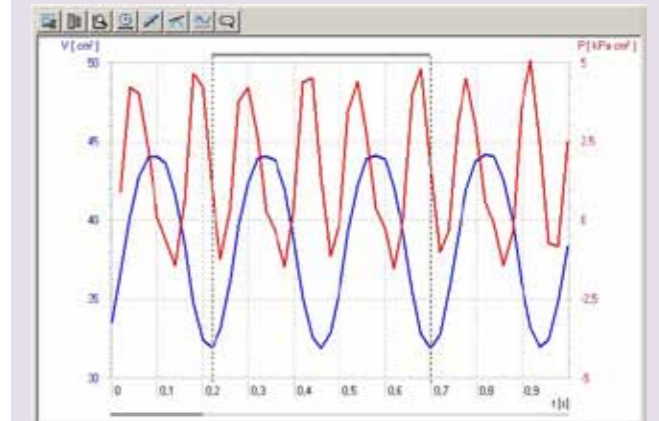

Fig. 2: $p(t)$, $V(t)$ and $P(t)$ plot for Stirling engine G



OBJECTIVE

Record and analyse the pressure-enthalpy diagram for a compression heat pump

EXPERIMENT PROCEDURE

- Demonstrate how an electric compression heat pump works.
- Quantitatively investigate of the related cyclical process.
- Record and analyse the pressure-enthalpy diagram for a compression heat pump.

SUMMARY

An electric compression heat pump consists of a compressor with a drive motor, a condenser, an expansion valve and an evaporator. Its functioning is based on a cyclical process with phase transition, through which the working medium in the pump passes; ideally, this process can be divided into the four steps comprising compression, liquefaction, depressurisation and evaporation. The theoretical performance coefficient of an ideal cyclical process can be calculated from the specific enthalpies h_1 , h_2 and h_3 read from a Mollier diagram. Determining the enthalpies h_2 and h_3 of an ideal cyclical process and the quantity of heat ΔQ_2 supplied to the hot water reservoir per time interval Δt makes it possible to estimate the mass flow of the working medium.

REQUIRED APPARATUS

Quantity	Description	Number
1	Heat Pump D (230 V, 50/60 Hz)	1000820 or
	Heat Pump D (115 V, 50/60 Hz)	1000819
2	Temperature Sensor, Pt100 with Measurement Terminal	1009922
1	3B NET/log™ (230 V, 50/60 Hz)	1000540 or
	3B NET/log™ (115 V, 50/60 Hz)	1000539
Additionally recommended:		
1	3B NET/lab™	1000544

BASIC PRINCIPLES

An electric compression heat pump consists of a compressor with a drive motor, a condenser, an expansion valve and an evaporator. Its operation is based on a cyclical process a phase transition, which the working medium inside the pump undergoes. Ideally, this process can be divided into four steps, comprising compression, liquefaction, depressurisation and evaporation.

2

For the compression part of the cycle, the gaseous working medium is drawn in by the compressor and compressed without any change in entropy ($s_1 = s_2$) from p_1 to p_2 , during which process the medium heats up (see Figs. 1 and 2). The temperature accordingly rises from T_1 to T_2 . The mechanical compression work performed per unit of mass is $\Delta w = h_2 - h_1$. Inside the condenser, the working medium cools considerably and condenses. The heat released as a result (excess heat and latent heat of condensation) per unit of mass is $\Delta q_2 = h_2 - h_3$. It raises the temperature of the surrounding reservoir. The condensed working medium reaches the release valve, where it is depressurised (without doing any mechanical work). In this process, the temperature also decreases due to the work which needs to be performed in opposition to the molecular forces of attraction inside the working medium (Joule-Thomson effect). The enthalpy remains constant ($h_4 = h_3$). As it absorbs heat inside the evaporator, the working medium evaporates fully. This cools the surrounding reservoir. The heat absorbed per unit of mass is $\Delta q_1 = h_1 - h_4$.

A Mollier diagram of the working medium is often used to represent the cycle of a compression heat pump. This diagram plots the pressure p against the specific enthalpy h of the working medium (enthalpy is a measure of the working medium's heat content and generally rises with the pressure and gas content).

Also specified are the isotherms ($T = \text{constant}$) and isentropes ($S = \text{constant}$), as well as the relative proportion by mass of the working medium in the liquid phase. The working medium condenses fully to the left of the vapourisation phase boundary line. The medium is present as superheated steam to the right of the condensation phase boundary and as a mixture of liquid and gas between the two lines. The two lines make contact at the critical point.

To depict the system in a Mollier diagram, the ideal cycle described above can be determined by measuring the pressures p_1 and p_2 respectively before and after the expansion valve, as well as the temperatures T_1 and T_3 respectively before the compressor and expansion valve.

The components in this experiment are connected via a copper pipe to form a closed system, and mounted on a base board. Thanks to the clarity of the set-up, it is easy to associate them with the sequence of phase changes taking place in the heat pump cycle. The evaporator and condenser are designed as coiled copper tubes and they are each immersed in a separate water bath which serves as a reservoir for determining absorbed or emitted heat. Two large manometers indicate the pressures on the refrigerant in the two heat exchangers. Two analog thermometers allow you to measure temperature in the two water baths. Temperature sensors with specially designed measuring terminals are used to register the temperatures in the copper tube before the compressor and the expansion valve.

The theoretical performance coefficient for an ideal cyclical process can be calculated from the specific enthalpies h_1 , h_2 and h_3 read from a Mollier diagram:

$$(1) \quad \eta_{\text{th}} = \frac{\Delta q_2}{\Delta w} = \frac{h_2 - h_3}{h_2 - h_1}$$

Determining the enthalpies h_2 and h_3 of the ideal cyclical process and the quantity of heat ΔQ_2 supplied to the hot water reservoir per time interval Δt makes it possible to estimate the mass flow of the working medium.

$$(2) \quad \frac{\Delta m}{\Delta t} = \frac{\Delta Q_2}{\Delta t} \cdot \frac{1}{h_2 - h_3}$$

EVALUATION

T_1 and p_1 determine point 1 in the Mollier diagram. The intersection where the relevant isentrope crosses the horizontal line $p_2 = \text{constant}$ determines point 2. The intersection with the vapourisation boundary line determines point 3, while a perpendicular to the horizontal line $p_4 = \text{constant}$ determines point 4.

Additional measurement of the temperature T_3 provides an advanced insight into the processes taking place in the heat pump. T_3 does not coincide with the temperature reading on the related manometer's temperature scale. This temperature scale is based on the vapour pressure curve for the working medium. The measurement therefore shows that the working medium before the expansion valve does not comprise a mixture of liquid and gas, but is entirely liquid.

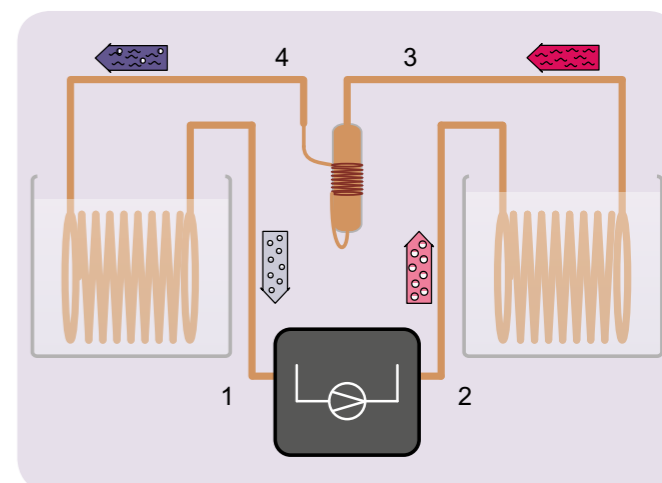

Fig. 1: Schematic representation of the heat pump with a compressor (1, 2), condenser (2, 3), expansion valve (3, 4) and evaporator (4, 1)

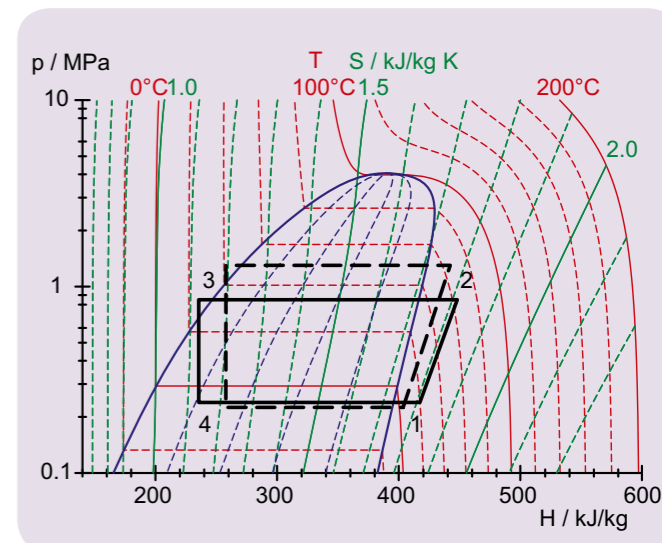

Fig. 2: Representation of ideal cyclical process for heat pump in a Mollier diagram



EXPERIMENT PROCEDURE

- Measuring the electric field within a plate capacitor as a function of the distance between the plates.
- Measuring the electric field within a plate capacitor as a function of the applied voltage.

OBJECTIVE

Measure the electric field in a plate capacitor using the electric field meter

SUMMARY

The electric field meter can be used to measure the electric field within a plate capacitor directly. In this experiment a rotating sectored disc interrupts the electrostatic flux falling on an induction plate, which forms part of a capacitor plate. The voltage pulses that are thereby generated are amplified to give an output voltage, which is then rectified to give a DC voltage that is proportional to the electric field E acting on the induction plate.

REQUIRED APPARATUS

Quantity	Description	Number
1	Electric Field Meter (230 V, 50/60 Hz)	1001030 or
	Electric Field Meter (115 V, 50/60 Hz)	1001029
1	DC Power Supply 450 V (230 V, 50/60 Hz)	1008535 or
	DC Power Supply 450 V (115 V, 50/60 Hz)	1008534
1	Digital Multimeter E	1006809
1	Analogue Multimeter AM50	1003073
1	Set of 15 Safety Experiment Leads, 75 cm	1002843

1

BASIC PRINCIPLES

The electric field meter can be used to measure electric fields directly. In front of an induction plate with four sectors in a star-shaped arrangement, a fan-like disc of similar shape is rotated. It continually interrupts the electrostatic flux, and thereby causes periodic induced charges, which are allowed to dissipate through a large resistance. The voltage pulses that are thereby generated are amplified to give an output voltage, which is then rectified to give a DC voltage that is proportional to the electric field E acting on the induction plate.

In the experiment, the electric field strength

$$(1) \quad E = \frac{U}{d}$$

in a plate capacitor is measured using the electric field meter. The applied voltage U and the distance d between the plates are varied in separate experimental runs.

EVALUATION

In applying Equation 1, one must take into account the fact that the induction plate is about 1 mm below the lower capacitor plate. Therefore, Equation 1 must be replaced by:

$$E = \frac{U}{d_{\text{eff}}} = \frac{U}{d + 1 \text{ mm}}$$

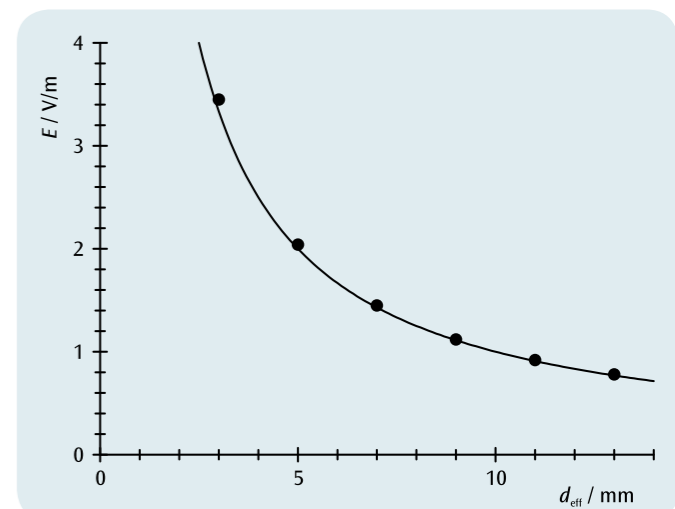

Fig. 1: Electric field inside the plate capacitor as a function of the effective distance between the plates

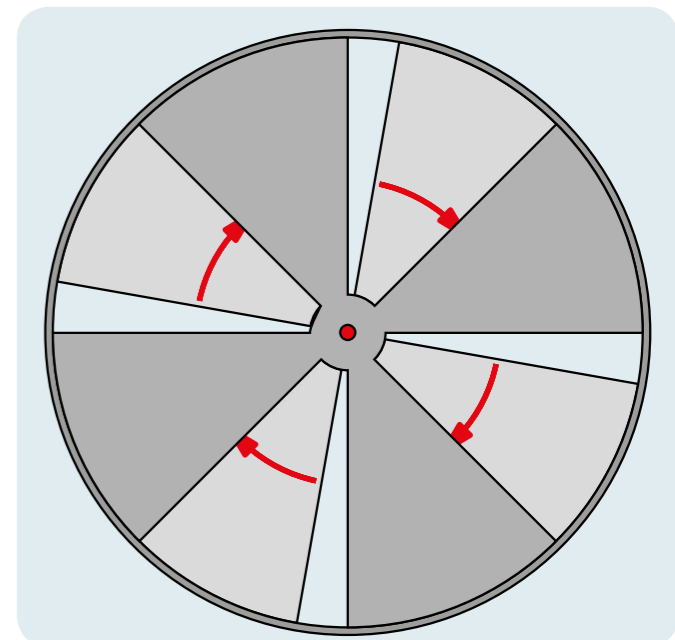

Fig. 2: Rotating sectored disc of the electric field meter



EXPERIMENT PROCEDURE

- Measuring the electrostatic voltage on a plate capacitor as a function of the distance between the plates.
- Confirming the proportionality between the voltage and the distance between the plates for small plate distances.

OBJECTIVE

Measure the electrostatic voltage as a function of the distance between the plates

SUMMARY

To increase the distance between the charged plates of a plate capacitor after removing their external connections, mechanical work must be performed. This can be demonstrated by measuring the resulting increase of the voltage between the plates using an electrostatic voltmeter.

REQUIRED APPARATUS

Quantity	Description	Number
1	Electric Field Meter (230 V, 50/60 Hz)	1001030 or
	Electric Field Meter (115 V, 50/60 Hz)	1001029
1	Plate Capacitor D	1006798
1	DC Power Supply 0 – 20 V, 0 – 5 A (230 V, 50/60 Hz)	1003312 or
	DC Power Supply 0 – 20 V, 0 – 5 A (115 V, 50/60 Hz)	1003311
1	Analogue Multimeter AM50	1003073
1	Set of 15 Experiment Leads, 75 cm 2.5 mm ²	1002841

1

BASIC PRINCIPLES

The charged plates of a plate capacitor exert an attractive force on each other. Therefore, to increase the distance between the plates of a capacitor that has been charged and its external connections removed, mechanical work must be performed. The additional energy supplied to the capacitor in this way can be measured as an increase of the voltage between the plates, provided that no current flows between the plates during the measurement.

A more precise description of this relation is obtained by considering the homogeneous electric field E between the plates of the capacitor, which carry the charges Q and $-Q$. The electric field strength is:

$$(1) \quad E = \frac{1}{\epsilon_0} \cdot \frac{Q}{A}$$

A : Area of each plate,

$$\epsilon_0 = 8.85 \cdot 10^{-12} \frac{\text{V} \cdot \text{s}}{\text{A} \cdot \text{m}} \quad \text{: Permittivity of free space}$$

If no current can flow if the plate distance d is changed, the charge Q and thus also the electric field E remain unchanged.

For small distances, for which the electric field can be assumed to be homogeneous, the voltage U on the capacitor and the electric field E are given by:

$$(2) \quad U = E \cdot d$$

d : Distance between the plates.

Thus, the voltage U is proportional to the distance between the plates d . In the experiment, this relationship is tested by using the electric field meter as an electrostatic voltmeter. This method ensures that no current can flow through the voltmeter between the capacitor plates and the charge Q on the plates remains unchanged.

EVALUATION

From Equation 2, a plot of U against d will give a straight line passing through the origin and through the measurement points, with a gradient corresponding to the constant electric field E . Deviations can be attributed to the fact that the electric field can no longer be assumed to be homogeneous with an increasing distance between the plates.

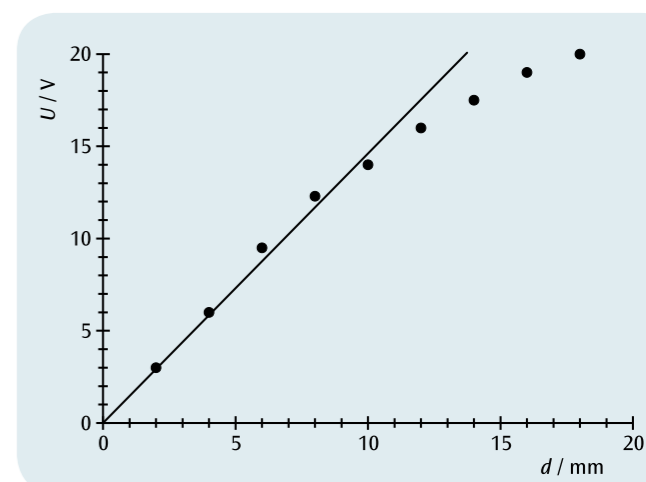

Fig. 1: Voltage U on the plate capacitor as a function of distance d between the plates



OBJECTIVE

Demonstrate the electric current generated by the motion of charged droplets of water

SUMMARY

Electric current arises due to an amount of charge being transported during a given interval of time. A flow of current can be simply illustrated with the help of charged droplets of water. In order to carry out the measurement, a burette and a Faraday cup connected to an electrometer will be used. The charge accumulated in the Faraday cup in a certain period of time is measured with the help of the voltage which drops across the capacitor. This allows the charge per droplet and the current to be determined.

EXPERIMENT PROCEDURE

- Measure the charge transferred to a Faraday cup by charged droplets of water dripping from a burette as a function of the time.
- Determine the current generated by the movement of the charged water droplets.
- Determine the charge on each droplet.

REQUIRED APPARATUS

Quantity	Description	Number
1	Electrometer (230 V, 50/60 Hz)	1001025 or
	Electrometer (115 V, 50/60 Hz)	1001024
1	Electrometer Accessories	1006813
1	Analogue Multimeter AM50	1003073
1	Burette, 10 ml	1018065
1	Constantan Wire 0.2 mm / 100 m	1000955
1	DC Power Supply 450 V (230 V, 50/60 Hz)	1008535 or
	DC Power Supply 450 V (115 V, 50/60 Hz)	1008534
1	Digital Multimeter P3340	1002785
1	Digital Stopwatch	1002811
1	Tripod Stand 150 mm	1002835
1	Stainless Steel Rod 1000 mm	1002936
2	Universal Clamp	1002830
1	Universal Jaw Clamp	1002833
1	Crocodile Clip 4 mm, Not Insulated	1002844
1	Set of 3 Safety Experiment Leads for Free Fall Apparatus	1002848
2	Pair of Safety Experimental Leads, 75cm, red/blue	1017718
1	Peleus ball, standard	1013392
1	Set of 10 Beakers, Low Form	1002872
Additionally recommended:		
1	3B NETlog™ (230 V, 50/60 Hz)	1000540 or
	3B NETlog™ (115 V, 50/60 Hz)	1000539
1	3B NETlab™	1000544

1

BASIC PRINCIPLES

Electric current arises due to an amount of charge being transported during a given interval of time. A flow of current can be simply illustrated with the help of charged droplets of water.

In this experiment a number of charged water droplets N drips at a constant rate of roughly one droplet per second from a burette into a Faraday cup connected to an electrometer and a capacitor. The charge Q accumulated in the Faraday cup causes the capacitor to charge up. The resulting voltage across the capacitor is observed and measured using an analogue multimeter for a certain period of time t . The high-resistance input of the operational amplifier in the electrometer ensures that the capacitor does not discharge via that path.

Observation of the analogue multimeter indicates that the voltage across the capacitor increases by about the same amount with every droplet collected in the Faraday cup, i.e. each of the droplets carries approximately the same charge:

$$(1) \quad q = \frac{Q}{N}$$

The current transported is given by

$$(2) \quad I = \frac{Q}{t}$$

As an option, the voltage across the capacitor can be recorded with the help of 3B NETlog™ and 3B NETlab™ as a function of time t and displayed in the form of a graph.

EVALUATION

The charge Q accumulated in the Faraday cup is determined by reading of the voltage U and calculating Q from that:

$$Q = C \cdot U \text{ where } C = 1 \text{ nF: capacitance of capacitor}$$

Using 3B NETlog™ and 3B NETlab™ the time characteristic $Q(t)$ can be measured. It is step-shaped whereby the individual steps mark the charge q that accumulates with each individual droplet per time interval Δt . The fact that each water droplet carries almost the same charge is reflected in the constant step height of the characteristic.

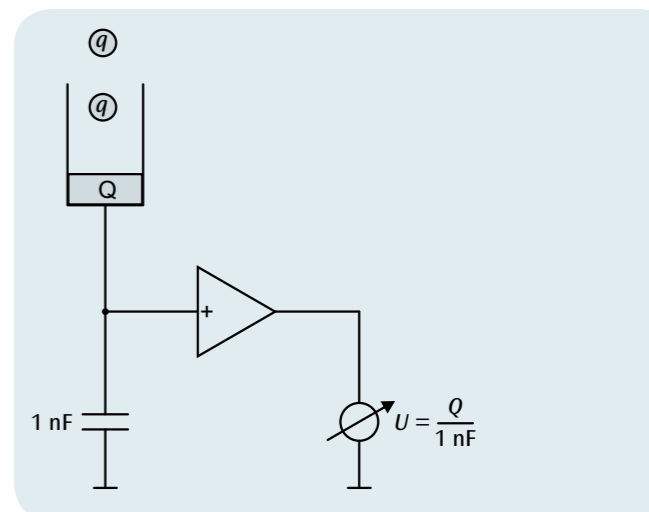

Fig. 1: Schematic illustrating the principle behind the measurement

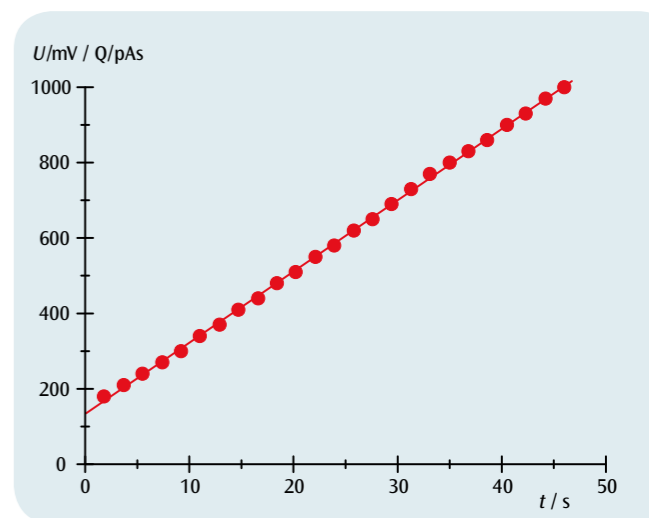

Fig. 2: Accumulated charge Q as a function of time t



EXPERIMENT PROCEDURE

- Measure voltage drop U as a function of distance d between contact points at a constant current I .
- Measure voltage drop U as a function of current I for a fixed distance d between contact points.
- Determine the electrical conductivity of copper and aluminium and make a comparison with values quoted in literature.

OBJECTIVE

Determine the electrical conductivity of copper and aluminium

SUMMARY

Electrical conductivity of a material is highly dependent on the nature of the material. It is defined as the constant of proportionality between the current density and the electric field in the material under investigation. In this experiment, four-terminal sensing is used to measure current and voltage in metal bars of known cross section and length.

REQUIRED APPARATUS

Quantity	Description	Number
1	Heat Conducting Rod Al	1017331
1	Heat Conducting Rod Cu	1017330
1	DC Power Supply, 1 – 32 V, 0 – 20 A (115 V, 50/60 Hz)	1012858 or
	DC Power Supply, 1 – 32 V, 0 – 20 A (230 V, 50/60 Hz)	1012857
1	Microvoltmeter (230 V, 50/60 Hz)	1001016 or
	Microvoltmeter (115 V, 50/60 Hz)	1001015
1	Digital Multimeter E	1006809
1	Set of 15 Experiment Leads, 75 cm 2.5 mm ²	1002841

1

BASIC PRINCIPLES

Electrical conductivity of a material is highly dependent on the nature of the material. It is defined as the constant of proportionality between the current density and the electric field in the respective material. In metals it is determined by the number density and mobility of electrons in the conduction band and is also dependent on temperature.

For a long metal conductor of cross-sectional area A and length d , a relationship between current I through the conductor and the voltage U which drops over a distance d along it can be deduced from the following formula:

$$(1) \quad j = \sigma \cdot E$$

j : current density, E : electric field

That relationship is as follows:

$$(2) \quad I = j \cdot A = A \cdot \sigma \cdot \frac{U}{d}$$

In the experiment, this relationship is used to determine the conductivity of metal bars using four-terminal sensing. This involves feeding in a current I through two wires and measuring the drop in voltage U between two contact locations separated by a distance d . Since the area of the cross section A is known, it is possible to calculate the conductivity σ .

The experiment uses the same metal bars investigated in the experiment on heat conduction, UE2020100. Two measurement probes are used to measure the voltage drop between the contact points, which can also be used to measure temperature along the bars.

NOTE

By comparing the measurements with the heat conductivity values obtained in experiment UE2020100 it is possible to verify the Wiedemann-Franz law. This states that thermal conductivity is proportional to electrical conductivity in metals and the factor is a universal value temperature-dependent coefficient.

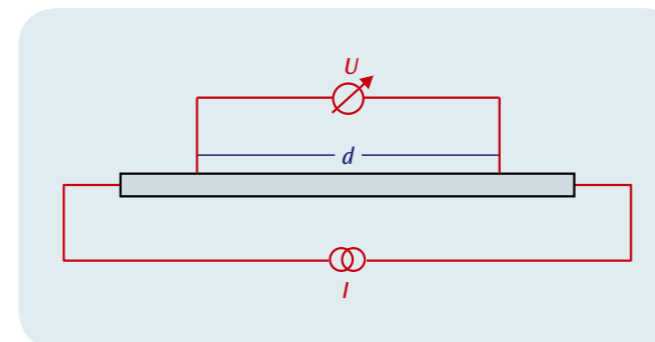

Fig. 3: Schematic of four-terminal sensing measurement

EVALUATION

The values measured for constant current I are plotted in a graph of U against d . Contact voltages between the measurement probes and the metal bar may become apparent by causing the straight lines to be shifted away from the origin. According to equation (2), the following is true

$$\alpha = \frac{I}{A \cdot \sigma}$$

Since I and A are known, it is possible to calculate the conductivity:

$$\sigma = \frac{I}{A \cdot \alpha}$$

The gradient of the U - I graph is

$$\beta = \frac{d}{A \cdot \sigma}$$

This implies that

$$\sigma = \frac{d}{A \cdot \beta}$$

Comparing the results with values quoted in literature for pure copper and aluminium, it can be seen that these metal bars are not made of pure metal but are actually copper or aluminium alloys.

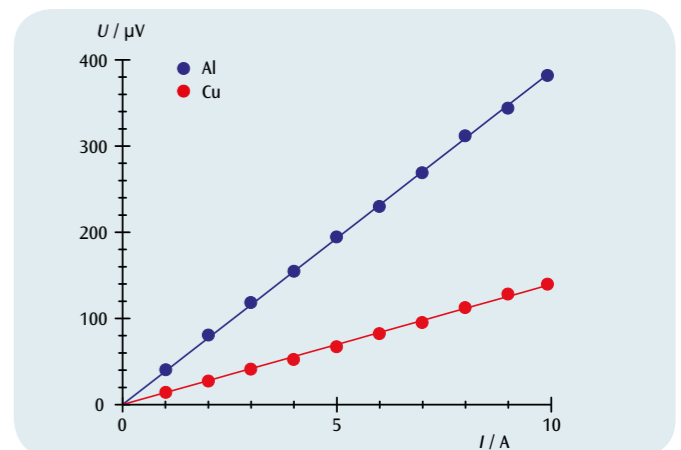

Fig. 1: Plot of U against I for copper and aluminium

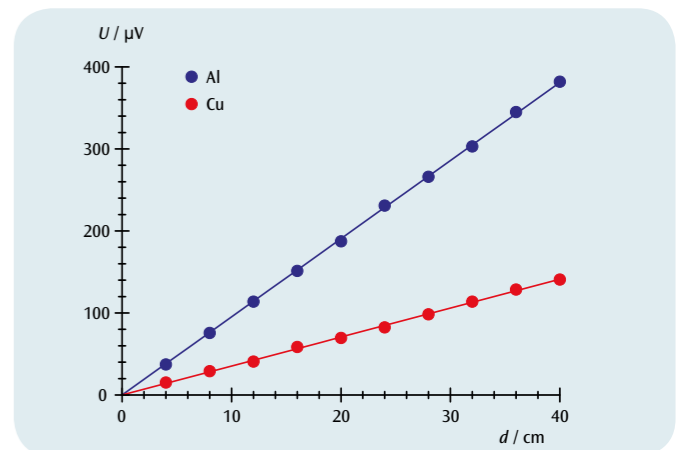
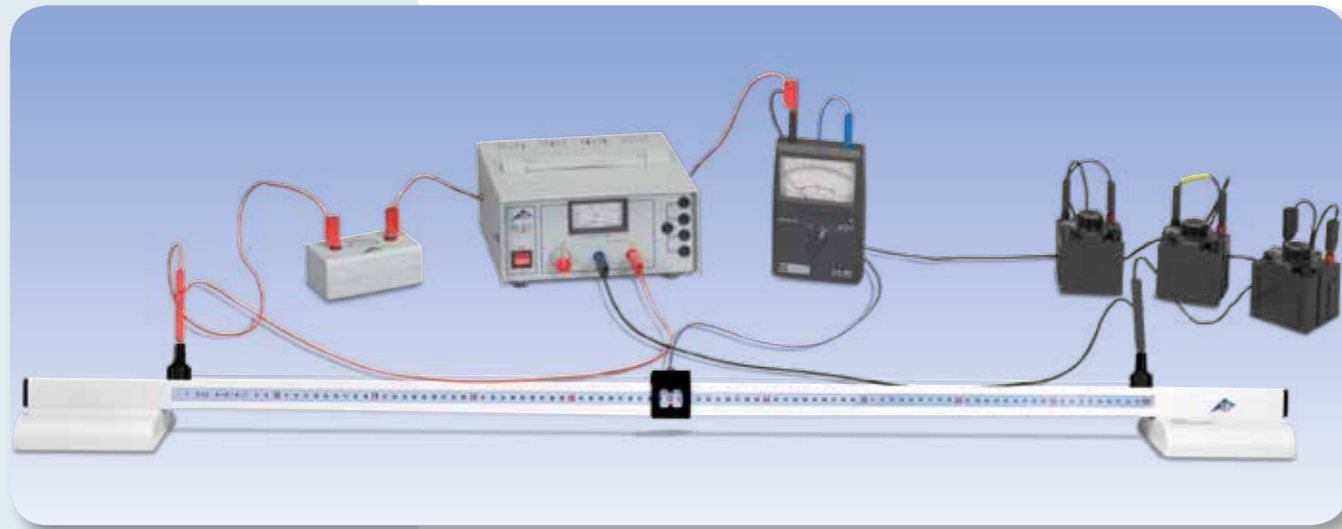

Fig. 2: Plot of U against d for copper and aluminium



EXPERIMENT PROCEDURE

- Determine resistances using a Wheatstone Bridge.
- Estimate the accuracy of the measurements.

OBJECTIVE

Determine the value of certain resistances

SUMMARY

An arrangement in which two voltage dividers are connected in parallel and connected to the same DC voltage source can be used to obtain the values of certain resistors. The first voltage divider consists of the resistance that is to be measured along with a reference resistance, while the second consists of a resistance wire 1 m in length that is divided into two sections by a sliding contact. The ratio between the two sections is adjusted until the current across the diagonal becomes zero.

REQUIRED APPARATUS

Quantity	Description	Number
1	Resistance Bridge	1009885
1	AC/DC Power Supply 0 – 12 V, 3 A (230 V, 50/60 Hz)	1002776 or
	AC/DC Power Supply 0 – 12 V, 3 A (115 V, 50/60 Hz)	1002775
1	Zero Point Galvanometer CA 403	1002726
1	Resistance Decade 1 Ω	1002730
1	Resistance Decade 10 Ω	1002731
1	Resistance Decade 100 Ω	1002732
1	Precision Resistor 1 Ω	1009843
1	Precision Resistor 10 Ω	1009844
1	Set of 15 Safety Experiment Leads, 75 cm	1002843

1

BASIC PRINCIPLES

A classical method for measuring resistances uses a voltage balancing bridge named after *Charles Wheatstone* to compare the unknown resistance with a reference resistance. This involves setting up a circuit consisting of two voltage dividers in parallel, with a single DC voltage source connected across the whole. The first voltage divider consists of the resistance R_x that is to be measured and a reference resistance R_{ref} , while the second consists of two resistances R_1 and R_2 , the sum of which remains constant during the balancing process (see Fig. 1).

The ratio between the resistances R_1 and R_2 and – if necessary – the value of the reference resistance R_{ref} are varied until the current across the diagonal is reduced to zero. This occurs when the ratio between the resistances is the same for both voltage dividers. This balance condition leads to the following expression for the unknown resistance R_x :

$$(1) \quad R_x = R_{ref} \cdot \frac{R_1}{R_2}$$

The accuracy of the result depends on the precision of the reference resistance R_{ref} , the resistance ratio R_1/R_2 and the sensitivity of the null-detecting galvanometer.

In this experiment the second voltage divider consists of a resistance wire 1 m in length, which is divided into two sections of lengths s_1 and s_2 by a sliding contact. As the sum $R_1 + R_2$ remains constant, the reference resistance should, so far as possible, be chosen so that the two sections have about the same length, and therefore similar resistance.

EVALUATION

As the two resistances R_1 and R_2 correspond to the two sections of the resistance wire, Equation (1) can be rewritten as

$$R_x = R_{ref} \cdot \frac{s_1}{s_2} = R_{ref} \cdot \frac{s_1}{1m - s_1}$$

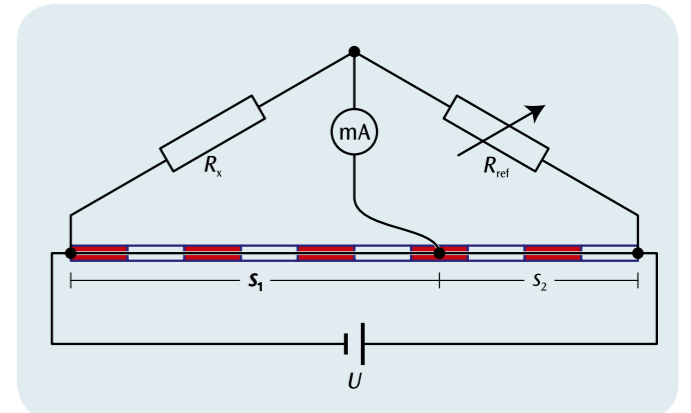
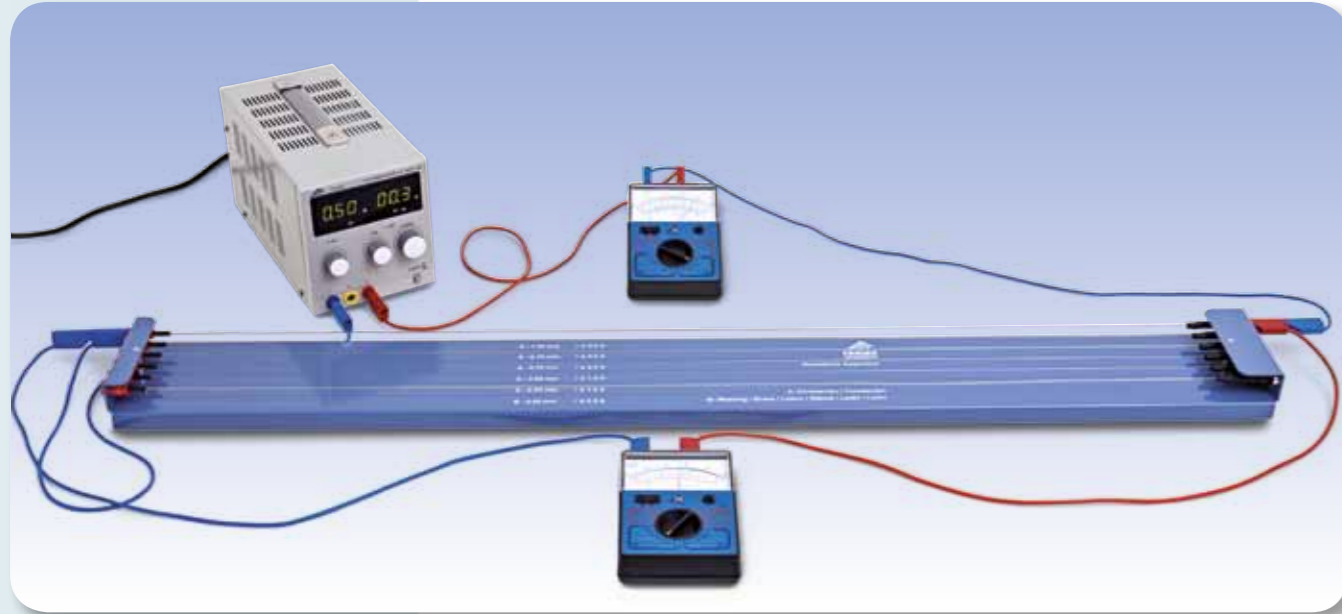

Fig. 1: Schematic diagram of a Wheatstone bridge



**EXPERIMENT
PROCEDURE**

- Verification of Ohm's law for a constantan wire and a brass wire.
- Verification of Ohm's law for constantan wires of various lengths.
- Verification of Ohm's law for constantan wires of various thickness.

OBJECTIVE

Verification of Ohm's law

SUMMARY

In simple electrical conductors, the current I which passes through the conductor is proportional to the applied voltage U . The constant of proportionality, the ohmic resistance R , is dependent on the length x of the conductor, its cross-sectional area A and the nature of the material. This relationship is to be investigated using constantan and brass wires.

REQUIRED APPARATUS

Quantity	Description	Number
1	Resistance Apparatus	1009949
1	DC Power Supply 0 – 20 V, 0 – 5 A (230 V, 50/60 Hz)	1003312 or
	DC Power Supply 0 – 20 V, 0 – 5 A (115 V, 50/60 Hz)	1003311
2	Analogue Multimeter AM50	1003073
1	Set of 15 Safety Experiment Leads, 75 cm	1002843



BASIC PRINCIPLES

Georg Simon Ohm was the first in 1825 to show that the current flowing through a simple conductor is proportional to the voltage applied.

This means that Ohm's law applies:

$$(1) \quad U = R \cdot I$$

The constant of proportionality R is the resistance of the conductor. For a metal wire of length x and cross-sectional area A , the resistance R is given by the following formula:

$$(2) \quad R = \rho \cdot \frac{x}{A}$$

The specific resistivity ρ depends on the material of which the wire is made. In order to verify this fundamental relationship, an experiment is to be carried out to investigate the proportionality between current and voltage for metal wires of varying thickness, length and material. The resistivity will also be determined and compared with values quoted in literature

EVALUATION

The cross-sectional area A is calculated from the thickness d of the wires:

$$A = \frac{\pi}{4} \cdot d^2$$

The measurements are to be plotted in three graphs of U against I . In each of these, one of the parameters ρ , x or d will be varied.

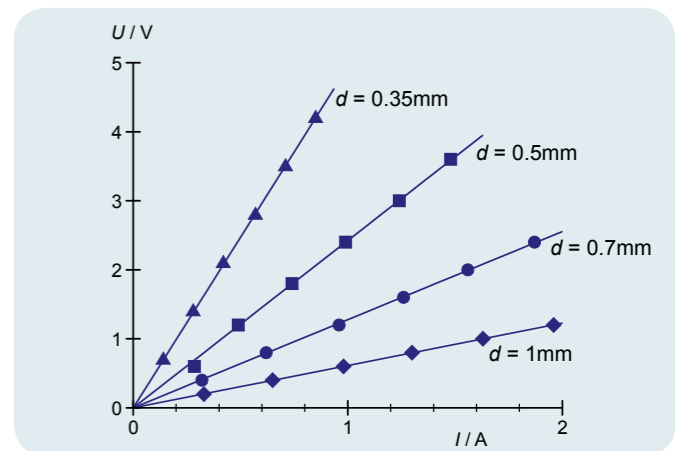

Fig. 3: Graph of U against I for constantan wires of various thickness

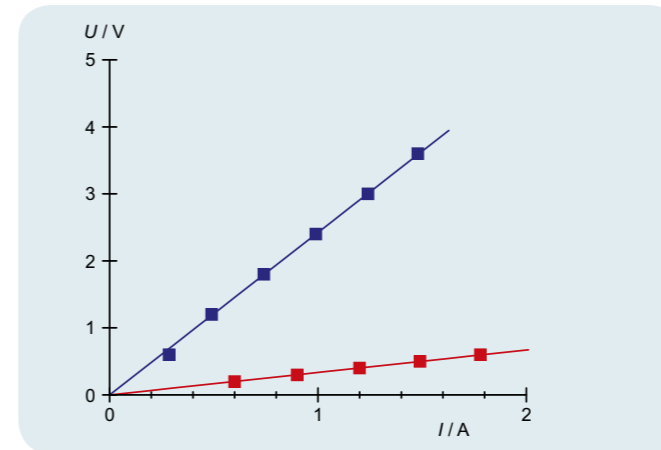

Fig. 1: Graph of U against I for constantan wire (blue) and brass wire (red)

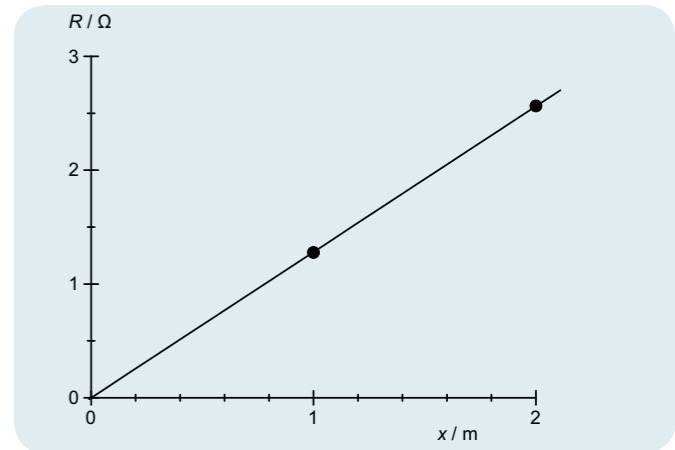

Fig. 4: Resistance R as a function of length

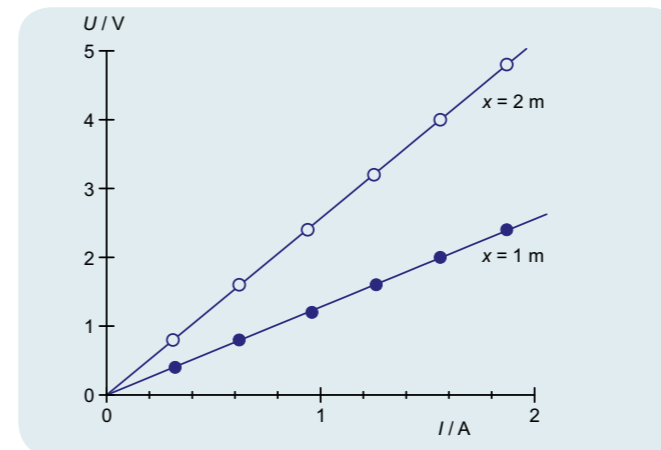

Fig. 2: Graph of U against I for constantan wires of various lengths

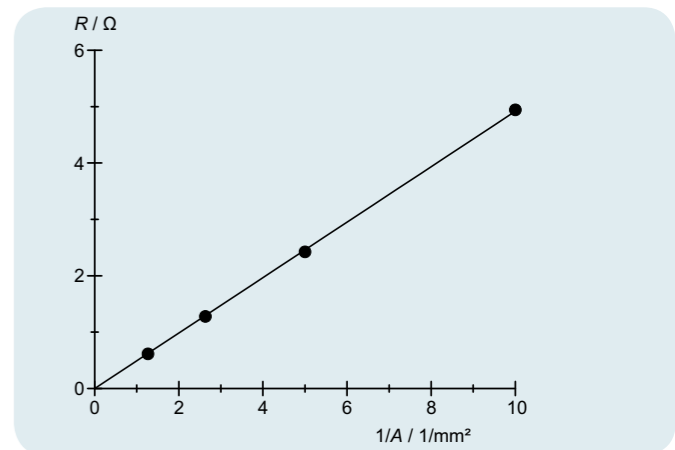
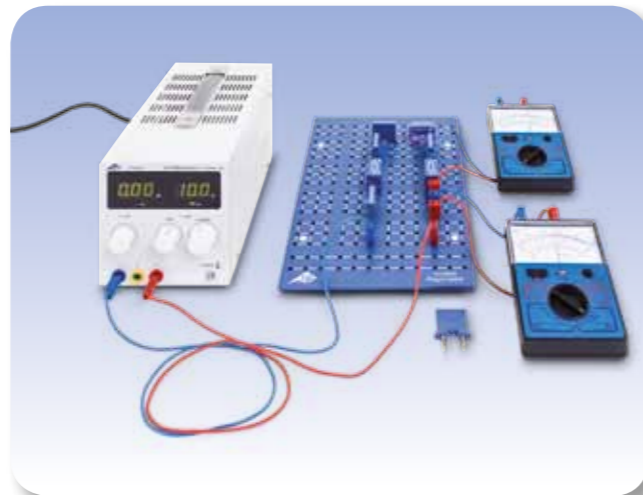
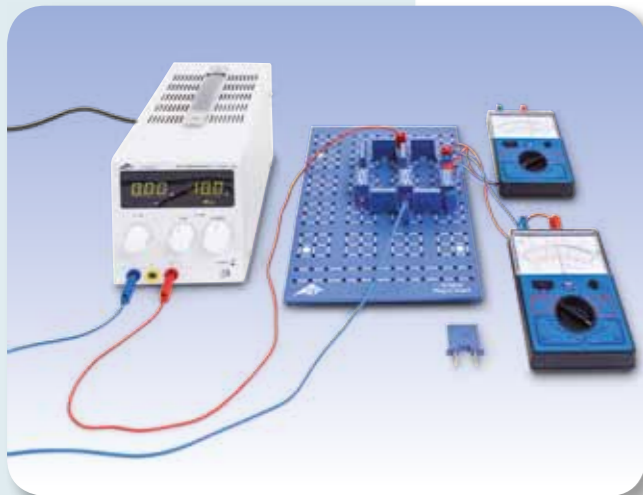

Fig. 5: Resistance R as a function of the inverse of the cross-sectional area A



EXPERIMENT PROCEDURE

- Verify Kirchhoff's laws for a circuit featuring resistors in series.
- Determine the overall resistance of a series circuit.
- Verify Kirchhoff's laws for a circuit featuring resistors in parallel.
- Determine the overall resistance of a parallel circuit.

OBJECTIVE

Measure voltage and current in circuits featuring resistors in series and in parallel

SUMMARY

Kirchhoff's laws are of key importance for calculating current and voltage in various parts of a circuit with multiple branches. In this experiment, Kirchhoff's laws will be verified by measuring voltage and current in various parts of circuits featuring resistors in series and parallel.

REQUIRED APPARATUS

Quantity	Description	Number
1	Plug-In Board for Components	1012902
1	Resistor 220 Ω, 2 W, P2W19	1012912
1	Resistor 330 Ω, 2 W, P2W19	1012913
1	Resistor 470 Ω, 2 W, P2W19	1012914
1	Resistor 1 kΩ, 2 W, P2W19	1012916
1	Resistor 6.8 kΩ, 2 W, P2W19	1012921
1	Resistor 10 kΩ, 0.5 W, P2W19	1012922
1	Resistor 100 kΩ, 0.5 W, P2W19	1012928
1	Set of 10 Jumpers, P2W19	1012985
1	DC Power Supply 0 – 20 V, 0 – 5 A (230 V, 50/60 Hz)	1003312 or
	DC Power Supply 0 – 20 V, 0 – 5 A (115 V, 50/60 Hz)	1003311
2	Analogue Multimeter AM50	1003073
1	Set of 15 Experiment Leads, 75 cm 1 mm ²	1002840

1

BASIC PRINCIPLES

In 1845 *Gustav Robert Kirchhoff* formulated laws describing the relationship between voltage and current in electric circuits which include multiple branches. Kirchhoff's 1st law (current law or junction rule) states that at every point where a circuit branches the sum of the currents flowing towards the junction are equal to the sum of currents flowing away from it. His 2nd law (voltage law, loop or mesh rule) states that, for any loop in any closed circuit, the sum of the voltages in all the branches is equal to the overall voltage provided by the source to that loop. For such loops, a direction of flow is defined. Currents flowing around the loop in the defined direction and voltages which cause such current to flow are considered to be positive, whereas if the currents flow in the opposite direction they are considered to be negative, along with the voltages driving them. These rules can, for example, be applied to circuits featuring resistors in series or in parallel.

In a circuit with n resistors in series, the current I is identical at every point in the circuit. According to Kirchhoff's second law, the sum of the voltages across each resistor will be equal to the voltage of the source to which they are connected.

$$(1) \quad U = U_1 + \dots + U_n$$

Therefore the following applies with respect to the overall resistance R_{ser} :

$$(2) \quad R_{ser} = \frac{U}{I} = \frac{U_1 + \dots + U_n}{I} = R_1 + \dots + R_n$$

For a circuit featuring resistors in parallel, so-called nodes or junctions arise for the current. Measurements at those nodes show that the sum of the current flowing towards them is equal to the sum of the currents flowing away from them. The voltages at each of these nodes are identical. Kirchhoff's 2nd law makes it possible to determine unknown currents at a node. The sum of the currents flowing through the resistors in each branch is equal to the overall current I , whereby the following is true:

$$(3) \quad I = I_1 + \dots + I_n$$

Therefore the following applies with respect to the overall resistance R_{par} :

$$(4) \quad \frac{1}{R_{par}} = \frac{I}{U} = \frac{I_1 + \dots + I_n}{U} = \frac{1}{R_1} + \dots + \frac{1}{R_n}$$

In this experiment, series and parallel circuits both featuring three resistors are investigated. To verify Kirchhoff's laws, the overall current and the current in each section will be measured along with the overall voltage and the voltage in each section.

EVALUATION

From the measurements on the series and parallel circuits, the overall resistance R is first to be calculated and then compared with the theoretical values obtained from equations (2) and (4).

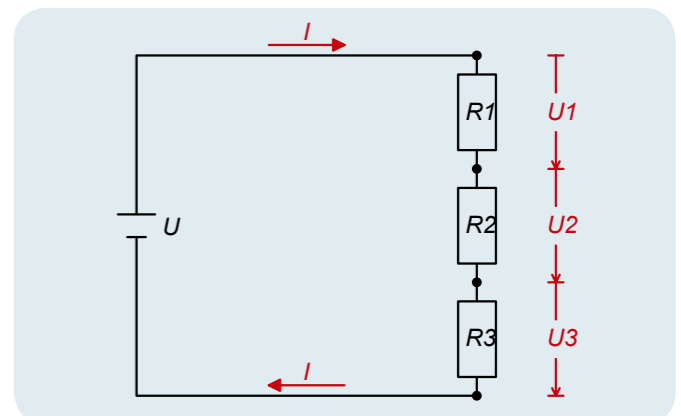

Fig. 1: Schematic for Kirchhoff's laws as applied to a circuit featuring resistors in series

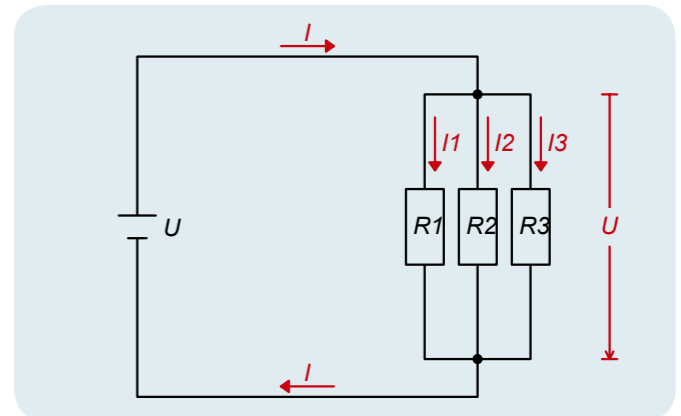
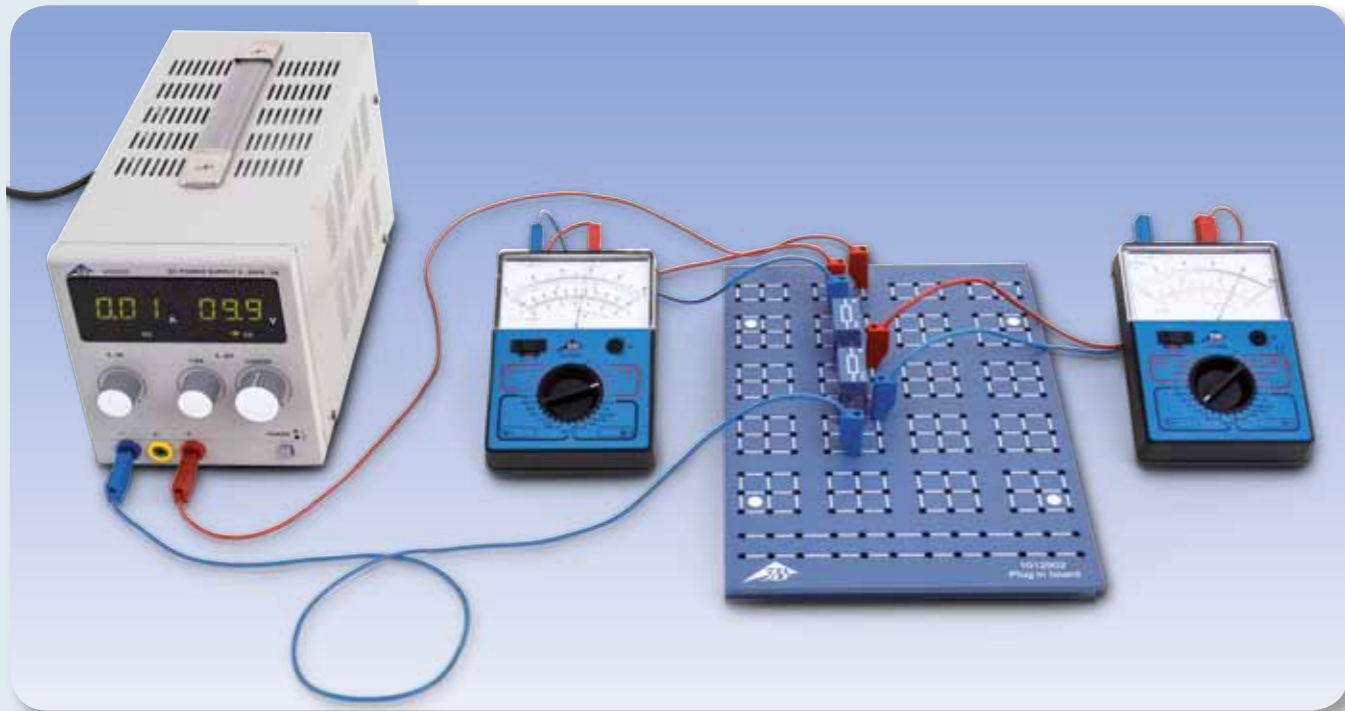

Fig. 2: Circuit diagram for a circuit featuring resistors in parallel



EXPERIMENT
PROCEDURE

- Measure voltage and current for a voltage divider with no load as a function of the resistance R_2 .
- Measure voltage and current for a voltage divider with no load for a constant overall resistance $R_1 + R_2$.
- Measure voltage and current for a voltage divider with a load as a function of the load resistance R_L .

OBJECTIVE

Measure the voltage and current for a voltage divider with and without a load

SUMMARY

A voltage divider in its simplest form consists of a pair of resistors connected in series, whereby the total voltage across the two of them is divided into two parts. A voltage divider is considered to be loaded when a further resistance is connected in parallel with one of the pair. The current and voltage in each part of the circuit are calculated as in any other series or parallel circuit using Kirchhoff's laws. When there is no load on the divider, the portions of the voltage can vary between 0 volts and the total voltage, depending on the individual resistors. There is a marked difference, however, when the circuit is loaded with very small loads. Then the voltage across the part of the circuit including the load will be very small regardless of the resistors in the divider.

REQUIRED APPARATUS

Quantity	Description	Number
1	Plug-In Board for Components	1012902
1	Resistor 47 Ω , 2 W, P2W19	1012908
2	Resistor 100 Ω , 2 W, P2W19	1012910
1	Resistor 150 Ω , 2 W, P2W19	1012911
1	Resistor 470 Ω , 2 W, P2W19	1012914
1	Potentiometer 220 Ω , 3 W, P4W50	1012934
1	DC Power Supply 0 – 20 V, 0 – 5 A (230 V, 50/60 Hz)	1003312 or
1	DC Power Supply 0 – 20 V, 0 – 5 A (115 V, 50/60 Hz)	1003311
2	Analogue Multimeter AM50	1003073
1	Set of 15 Experiment Leads, 75 cm 1 mm ²	1002840



BASIC PRINCIPLES

A voltage divider in its simplest form consists of a pair of resistors connected in series, whereby the total voltage across the two of them is divided into two parts. A voltage divider is considered to be loaded when a further resistance is connected in parallel with one of the pair. The current and voltage in each part of the circuit are calculated as in any other series or parallel circuit using Kirchhoff's laws

When there is no load on the divider, the overall resistance is given by the following equation (see Fig. 1)

$$(1) \quad R = R_1 + R_2$$

The same current flows through both resistors

$$(2) \quad I = \frac{U}{R_1 + R_2}$$

U : Overall voltage

Therefore the voltage across R_2 is given by the following:

$$(3) \quad U_2 = I \cdot R_2 = U \cdot \frac{R_2}{R_1 + R_2}$$

When the divider is loaded, the load resistance R_L also needs to be taken into account (see Fig. 2), whereby the value of R_2 in the above equation is replaced by the following expression:

$$(4) \quad R_p = \frac{R_2 \cdot R_L}{R_2 + R_L}$$

Thus the voltage U_2 in that part of the circuit is now given by

$$(5) \quad U_2 = I \cdot R_p = U \cdot \frac{R_p}{R_1 + R_p}$$

In this experiment, an unloaded voltage divider is assembled using two discrete resistors R_1 and R_2 with resistors of various different values being used as R_2 . Alternatively, a potentiometer can be used, in which case the total resistance $R_1 + R_2$ is inherently constant and the value of R_2 depends on the position of potentiometer's sliding contact. The voltage source supplies a constant value U , which remains unchanged for the whole experiment. In each case the voltage and the current is measured for each section of the circuit.

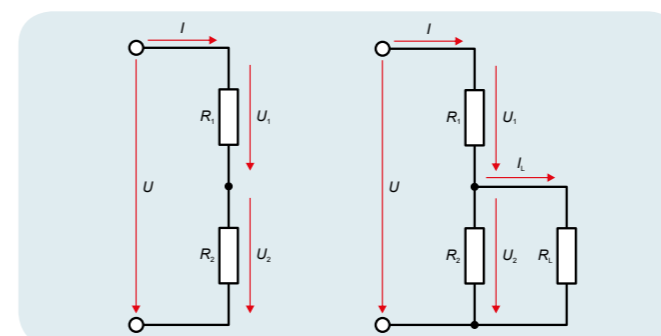

Fig. 1: Circuit diagram of a voltage divider with no load

Fig. 2: Circuit diagram of a voltage divider with a load

EVALUATION

In a voltage divider without a load, the voltage U_2 corresponds to the overall voltage U , if R_2 is very much larger than R_1 but is close to zero if R_2 is very small in comparison.

For a voltage divider with a load of comparatively large magnitude, the resistance of the parallel section effectively equates to $R_p = R_2$ and the voltage in the section U_2 is then given by equation (3). The situation is very different if the load resistance is very small. In that case $R_p = R_L$, since most of the current flows through the load. The voltage U_2 then becomes very small regardless of the value of R_2 .

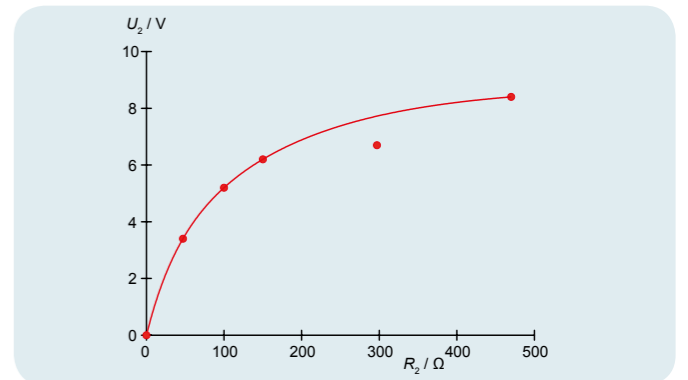

Fig. 3: Voltage U_2 as a function of resistance R_2 in a voltage divider with no load

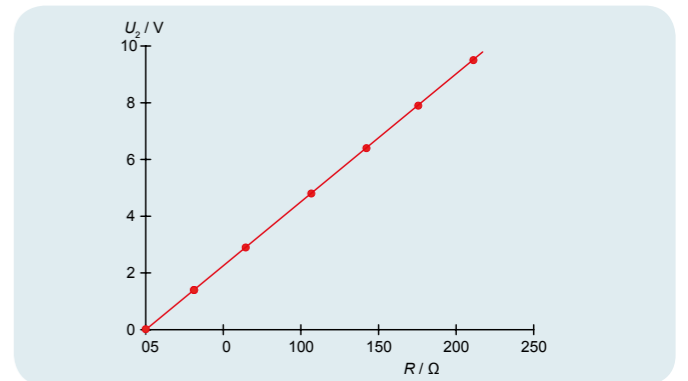

Fig. 4: Voltage U_2 as a function of resistance R_2 in a voltage divider with no load and a constant overall resistance $R_1 + R_2$

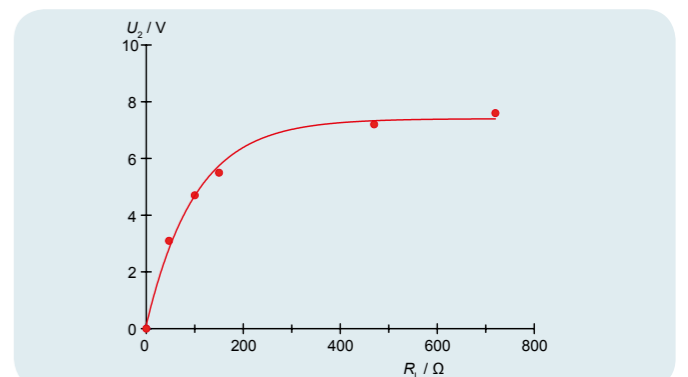

Fig. 5: Voltage U_2 as a function of resistance R_2 in a voltage divider with a load



EXPERIMENT PROCEDURE

- Generating hydrogen by electrolysis and measuring the volume of hydrogen V .
- Measuring the electrical work W needed to generate the hydrogen at a constant voltage U_0 .
- Calculating the Faraday constant F .

1

OBJECTIVE

Determine the Faraday constant

SUMMARY

The Faraday constant is determined by measuring the quantities of hydrogen and oxygen generated by the electrolysis of water and the electric charge that is transported during the process.

REQUIRED APPARATUS

Quantity	Description	Number
1	Hofmann's Voltmeter	1002899
1	Power and Energy Meter with Interface (230 V, 50/60 Hz)	1003132 or
	Power and Energy Meter with Interface (115 V, 50/60 Hz)	1003131
1	DC Power Supply 0 – 20 V, 0 – 5 A (230 V, 50/60 Hz)	1003312 or
	DC Power Supply 0 – 20 V, 0 – 5 A (115 V, 50/60 Hz)	1003311
1	Set of 15 Experiment Leads, 75 cm 1 mm ²	1002840

Additionally required:

Sulphuric Acid, 1 mol/l

BASIC PRINCIPLES

Electrolysis is the breakdown of a chemical compound by the action of an electric current. When this occurs, the process of electrical conduction is accompanied by a release of material, and the quantity of material released, n is proportional to the transported charge Q . The proportionality constant is called the Faraday constant F and it is a universal constant of nature.

For a fuller and more accurate description of the proportionality relationship between the charge Q and the molar quantity n of material that is released, one must also take into account the valence number z of the ions that are released. Thus

$$(1) \quad Q = F \cdot n \cdot z$$

In this manner, the Faraday Constant can be determined by measuring the charge Q and the molar quantity n for an electrolytic process, provided the valence number is known.

In the experiment, water is electrolysed to generate a specific quantity of hydrogen and oxygen. To determine the charge Q that is transported, the electrical work

$$(2) \quad W = Q \cdot U_0$$

that is performed at constant voltage U_0 to achieve electrolysis is measured.

The molar quantity n_H of hydrogen ions that is released at room temperature T and external pressure p is determined from the measured volume V_{H_2} of the gas. However, one must take into account the fact that the hydrogen is collected in molecular form, and for each hydrogen molecule collected, two hydrogen ions have been released. Thus, from the equation of state for an ideal gas we have:

$$(3) \quad n_H = 2 \cdot \frac{p \cdot V_{H_2}}{R \cdot T}$$

$$R = 8.314 \frac{\text{J}}{\text{mol} \cdot \text{K}}: \text{ the universal gas constant.}$$

EVALUATION

The valence number of hydrogen ions is $z_H = 1$. Therefore, from Equations 1, 2 and 3, we obtain the following equation for determining the Faraday constant:

$$F = \frac{W}{U_0} \cdot \frac{R \cdot T}{2 \cdot p \cdot V_{H_2} \cdot n_H} = \frac{W}{U_0} \cdot \frac{R \cdot T}{2 \cdot p \cdot V_{H_2}}$$

For comparison, we can also measure the volume of oxygen that is collected, V_{O_2} . It is only half of the hydrogen volume, because each water molecule that is electrolysed releases two hydrogen ions and one oxygen ion. However, the valence number for oxygen ions is $z_O = 2$.

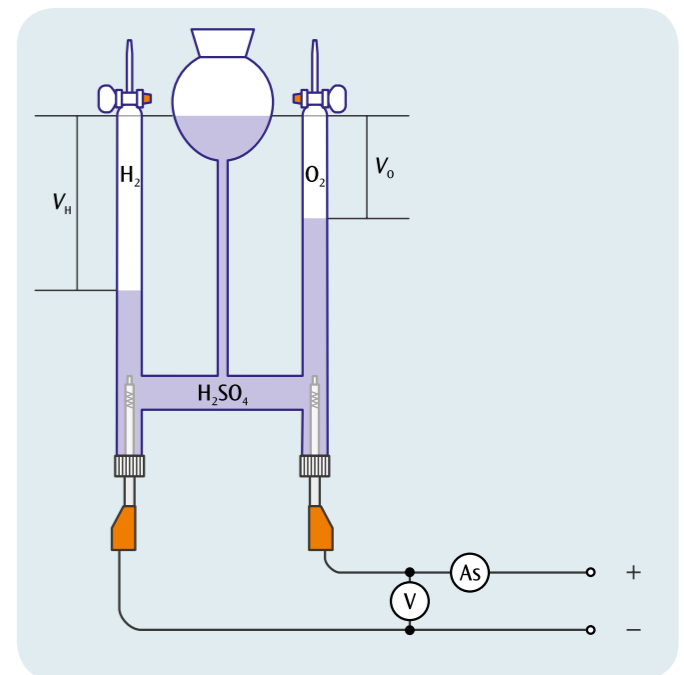
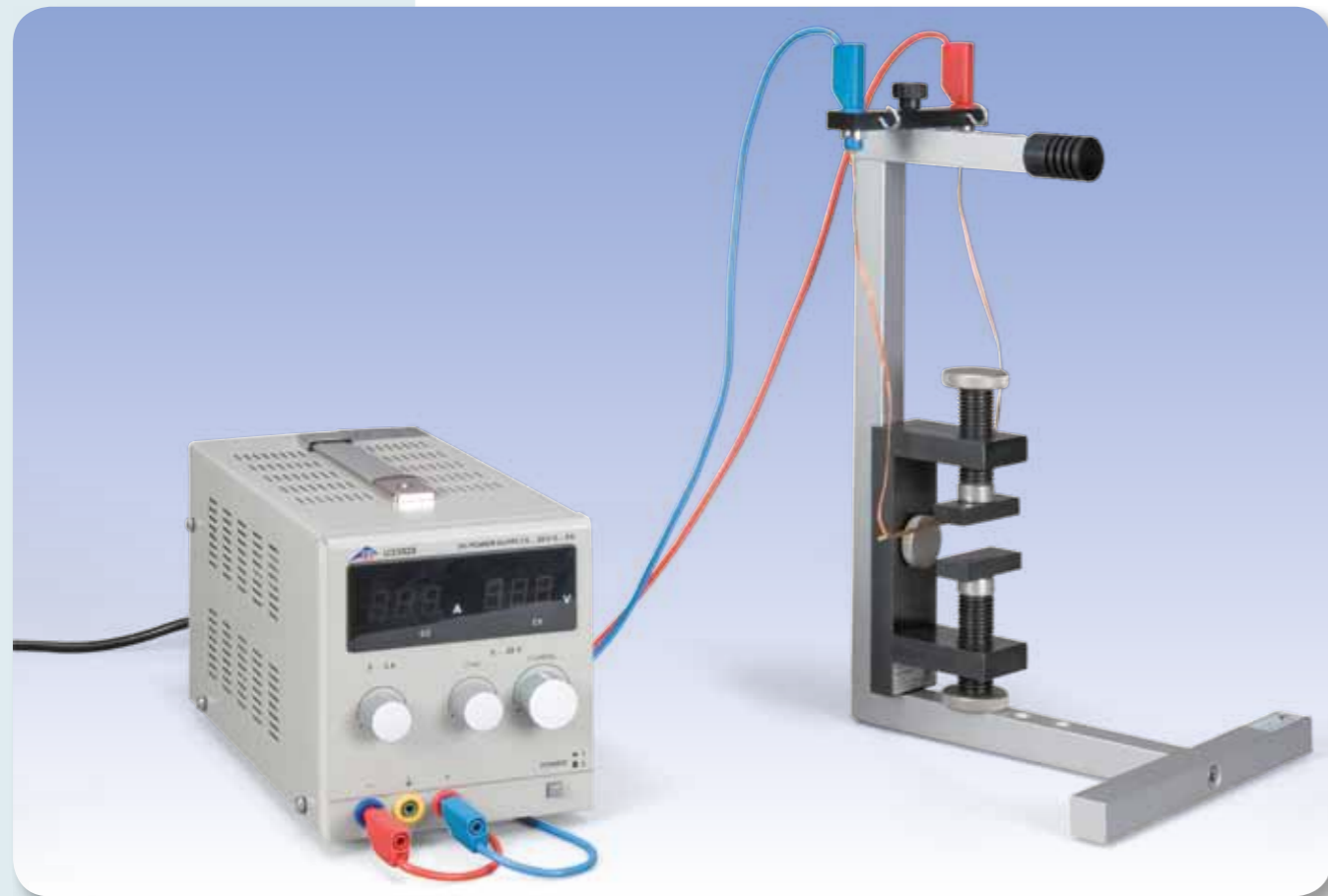

Fig. 1: Schematic diagram



EXPERIMENT PROCEDURE

- Determine the direction of the Lorentz force.
- Measure the force as a function of the current.
- Measure the force as a function of the effective length of the conductor.
- Measure the force as a function of the distance between the pole-shoes of the permanent magnet.

OBJECTIVE

Measure the force on a current-carrying conductor in a magnetic field

SUMMARY

The experiment involves measuring the Lorentz force on a current-carrying copper rod suspended in a horizontal position from a pair of vertical wires (like a swing) and subjected to a magnetic field. When the current is switched on the “swing” is deflected from the vertical position and the Lorentz force can be calculated from the angle of deflection. The current through the rod, the magnetic field strength and the effective length of the conductor in the magnetic field are varied and the effects are measured.

REQUIRED APPARATUS

Quantity	Description	Number
1	Equipment Set Electromagnetism	1002661
1	Permanent Magnet with Adjustable Pole Spacing	1002660
1	DC Power Supply 0 – 20 V, 0 – 5 A (230 V, 50/60 Hz)	1003312 or
	DC Power Supply 0 – 20 V, 0 – 5 A (115 V, 50/60 Hz)	1003311
1	Pair of Safety Experimental Leads, 75cm, red/blue	1017718

1

BASIC PRINCIPLES

Electrons moving in a magnetic field are deflected in a direction perpendicular to the magnetic field and also perpendicular to the direction of motion. However, the deflecting force on a single electron – the Lorentz force – cannot easily be measured in practice, as it is extremely small, even for an electron moving very fast in a very strong magnetic field. A different situation exists when a current-carrying conductor is placed in a uniform magnetic field. In the conductor there are a large number of charge-carriers, all moving with the same drift velocity v . A force then acts on the conductor, which results from the sum of the Lorentz force components on all the individual charge-carriers.

In a straight conductor of length L and cross-sectional area A , the total number of electrons is:

$$(1) \quad N = n \cdot A \cdot L$$

n : Electrons per unit volume

If the electrons move with a drift velocity v in the direction of the length of the conductor, the current I through it is as follows:

$$(2) \quad I = n \cdot e \cdot A \cdot v$$

e : Elementary charge of an electron.

If the conductor is in a magnetic field of flux density B , the combined Lorentz force on all the “drifting” electrons is as follows:

$$(3) \quad F = N \cdot e \cdot v \times B$$

If the axis of the conductor is perpendicular to the magnetic field direction, Equation (3) can be simplified to the following:

$$(4) \quad F = I \cdot B \cdot L$$

Then the force F is perpendicular to the axis of the conductor and to the magnetic field.

The experiment involves measuring the Lorentz force F on a current-carrying copper rod, suspended in a horizontal position from a pair of vertical wires (like a swing) and subjected to a magnetic field (see Fig. 1). When the current is switched on the “swing” is deflected by an angle ϕ from the vertical position by the Lorentz force F , which can then be calculated from Equation (5).

$$(5) \quad F = m \cdot g \cdot \tan \phi$$

$m = 6.23$ g, the mass of the copper rod.

The magnetic field B is provided by a permanent magnet, and can be varied by altering the distance d between the pole-shoes of the magnet. It is also possible to rotate the pole-shoes through 90° , thus changing the width L along the direction of the conductor and thereby the effective length L of the conductor, i.e. the part of it that is inside the magnetic field. This effective length L is slightly greater than the width b of the space between the pole-shoes, as the magnetic field “bulges out”, forming a non-uniform region beyond the edges of the pole-shoes. The extent of this non-uniform part of the field increases with the distance d between the pole-shoes. To a good approximation:

$$(6) \quad L = b + d$$

EVALUATION

The angle ϕ can be determined from the length of the pendulum s (the supporting wires) and the horizontal deflection x of the copper rod:

$$\frac{x}{\sqrt{s^2 - x^2}} = \tan \phi$$

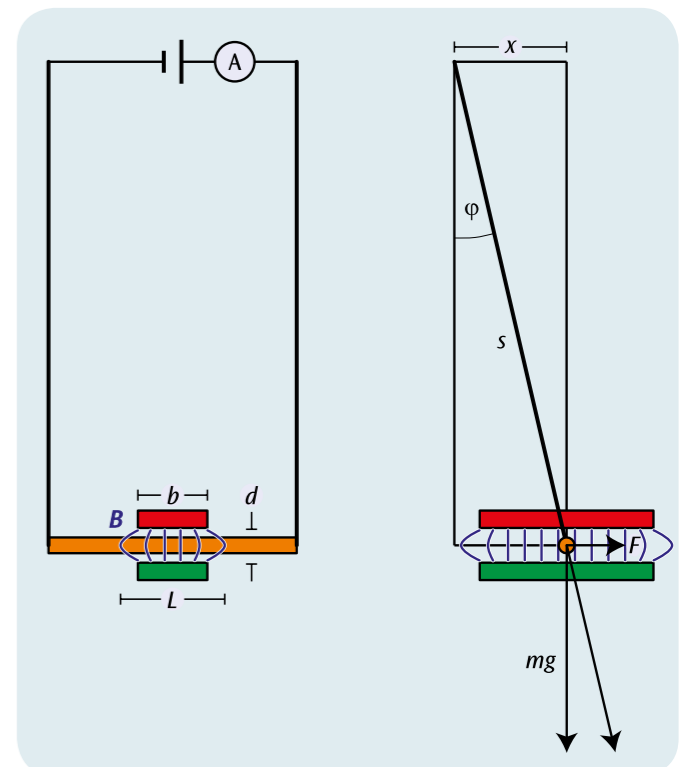

Fig. 1: Experiment set-up, viewed from the side and from the front

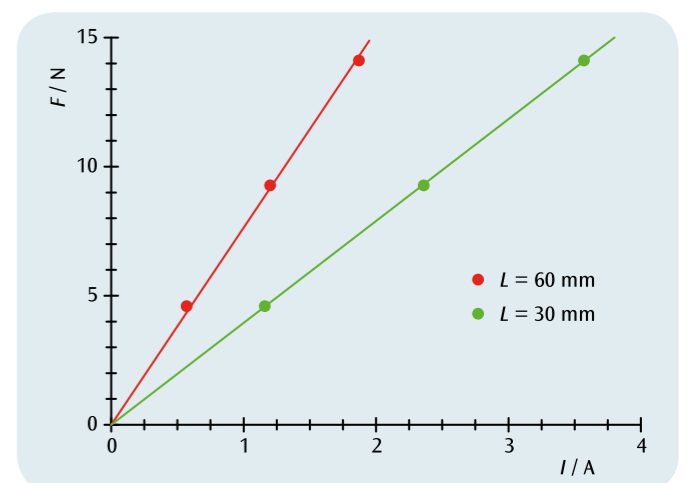
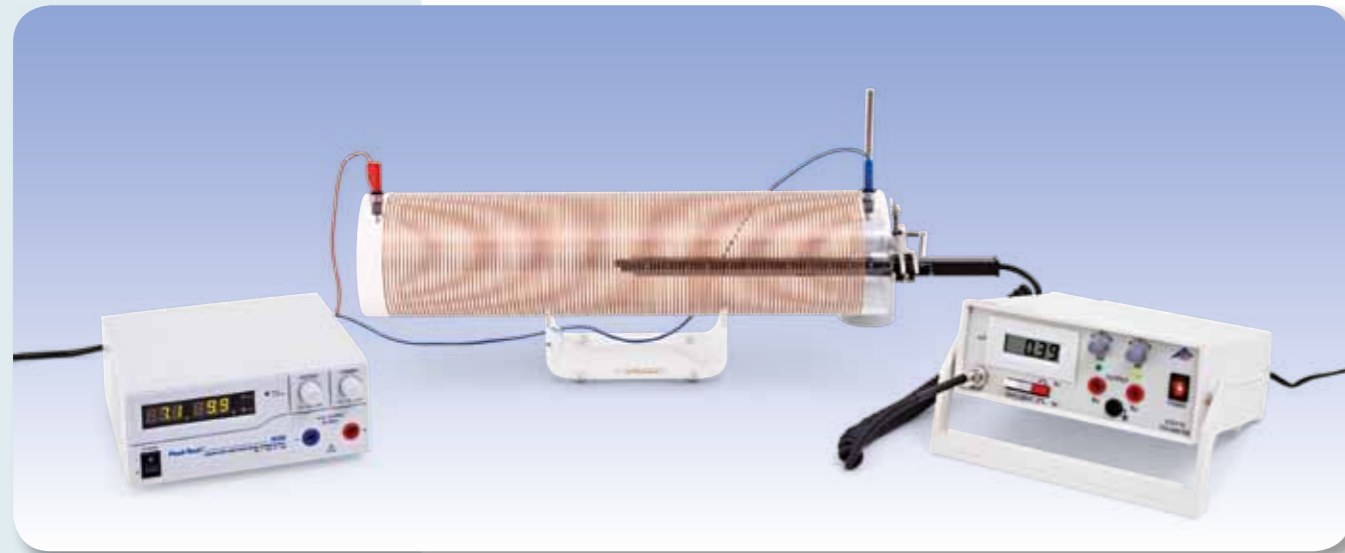

Fig. 2: Force on a current-carrying conductor as a function of current I for two different effective conductor lengths L . The gradients of the straight lines through the origin are proportional to L



EXPERIMENT PROCEDURE

- Determine the magnetic flux density B inside a cylindrical coil as a function of the current I .
- Measure the magnetic flux density B inside a cylindrical coil with coils that can be moved closer together or farther apart as a function of the current I .
- Determine that for long coils, the magnetic flux density is proportional to the density of the windings (how close they are together).

OBJECTIVE

Determine the magnetic field generated by coils of various lengths

SUMMARY

The magnetic flux density inside a long cylindrical coil is directly proportional to the current through the coil and how close together the coil windings are, but is not dependent on the radius of the coil as long as the length of the coil is comparatively much greater than its diameter. That will be demonstrated in this experiment using two coils of different diameter and another coil in which the separation of the coil windings can be increased or decreased.

REQUIRED APPARATUS

Quantity	Description	Number
1	Field Coil 100 mm	1000591
1	Field Coil 120 mm	1000592
1	Coil with Variable Number of Turns per Unit Length	1000965
1	Stand for Cylindrical Coils	1000964
1	Teslameter 200 mT (230 V, 50/60 Hz)	1003314 or
	Teslameter 200 mT (115 V, 50/60 Hz)	1003313
1	DC Power Supply, 1 – 32 V, 0 – 20 A (115 V, 50/60 Hz)	1012858 or
	DC Power Supply, 1 – 32 V, 0 – 20 A (230 V, 50/60 Hz)	1012857
1	Set of 15 Experiment Leads, 75 cm 2.5 mm ²	1002841
1	Barrel Foot, 1000 g	1002834
1	Stainless Steel Rod 250 mm	1002933
1	Universal Clamp	1002830
1	Universal Jaw Clamp	1002833

1

BASIC PRINCIPLES

The Biot-Savart law describes the relationship between magnetic flux density B and electric current I through a conductor of any arbitrary geometry. The calculation involves adding the contributions of infinitesimally small sections of conductor to find the overall magnetic flux density. The overall field is then determined by integrating over the geometry of the conductor. In some cases, e.g. for a long cylindrical coil, there is a simple analytical solution to this integration.

According to the Biot-Savart law, an infinitesimally small section of conductor ds through which a current I is flowing, generates the following magnetic flux density at the point r

$$(1) \quad dB(r) = \frac{\mu_0}{4\pi} \cdot I \cdot \frac{ds \times r}{r^3}$$

B : magnetic flux density

$$\mu_0 = 4\pi \cdot 10^{-7} \frac{\text{Vs}}{\text{Am}} \text{ : permeability of free space}$$

Inside the cylindrical coil, the magnetic flux density is aligned parallel to the axis of the cylinder and is given by the following expression:

$$(2) \quad B = \mu_0 \cdot \frac{N}{L} \cdot I$$

N : number of windings, L : length of coil

This applies as long as the length of the coil is much greater than its radius. The magnetic flux density does not therefore depend on the diameter of the coil and is proportional to the density of the windings, i.e. the number of windings per unit length, and the current through the coil.

The experiment involves using an axial teslameter to measure the magnetic flux density inside long coils for currents of up to 20 A. It demonstrates that the flux density does not depend on the coil diameter but is proportional to the current and the winding density. In order to prove the latter, a coil is provided which allows the windings to be moved closer together or farther apart, i.e. varying the number of windings per unit length.

EVALUATION

All the measurements confirm that the magnetic flux density B is proportional to the current I through the coil. The flux density is confirmed to be proportional to the windings per unit length as long as the length of the coil is more than three times its radius.



Fig. 1: Coil with variable number of windings per unit length

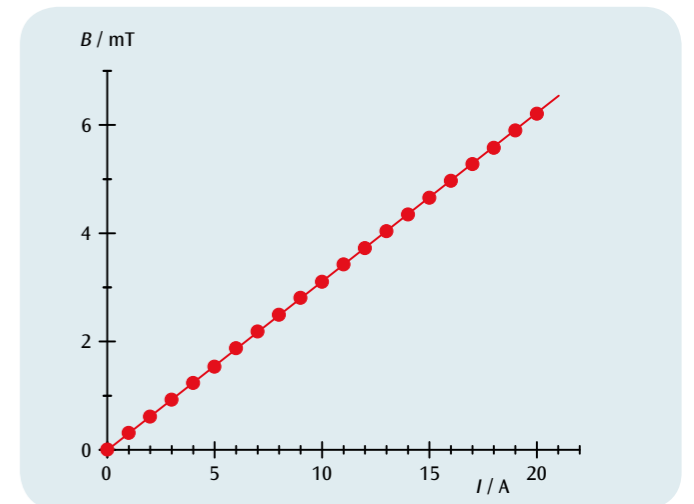

Fig. 2: Magnetic flux density B as a function of current I

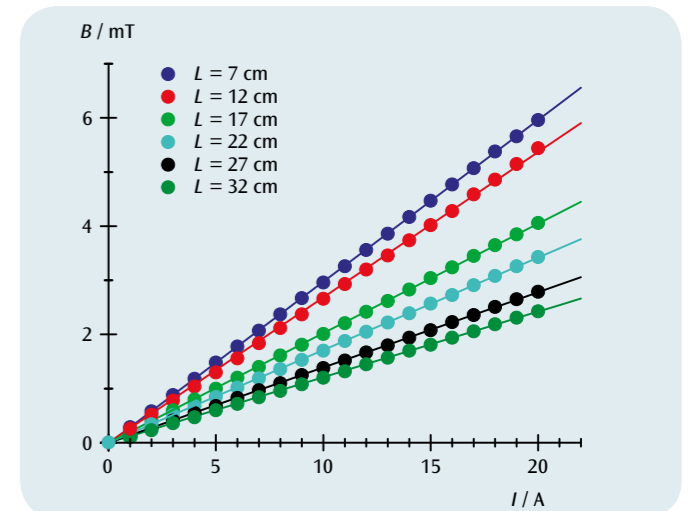

Fig. 3: Magnetic flux density B as a function of current I using the coil with a variable number of windings per unit length for various lengths of coil L

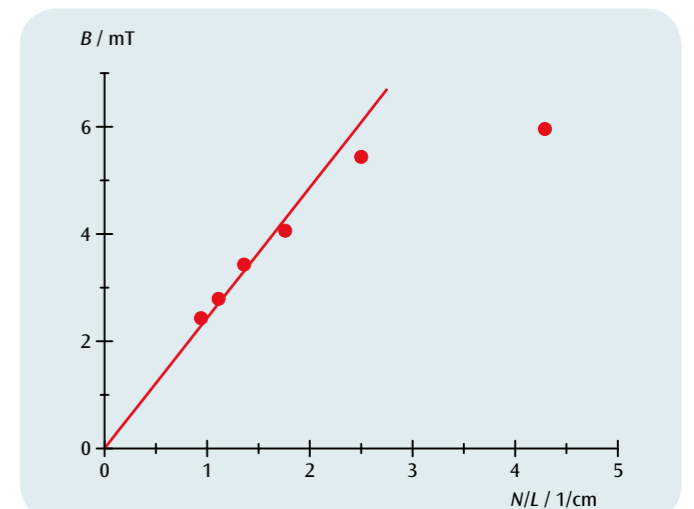

Fig. 4: Magnetic flux density B as a function of number of windings per unit length N/L when $I = 20$ A



EXPERIMENT PROCEDURE

- Measure the angle of rotation of a compass needle initially aligned parallel with the horizontal component of earth's magnetic field when a second horizontal magnetic field is superimposed with the help of a pair of Helmholtz coils.
- Determine the horizontal component of the earth's magnetic field.
- Measure the inclination and vertical component and calculate the overall magnitude of the earth's magnetic field.

OBJECTIVE

Determine the horizontal and vertical components of the earth's magnetic field

SUMMARY

This experiment involves determining the inclination and magnitude of the earth's magnetic field as well as its horizontal and vertical components at the point where the measurement is made. The horizontal component of the earth's field can be found from the turning of a compass needle when an additional magnetic field is applied by means of a pair of Helmholtz coils. By measuring the angle of inclination, it is also possible to work out the vertical component and calculate the overall magnitude of the earth's magnetic field.

REQUIRED APPARATUS

Quantity	Description	Number
1	Helmholtz Coils 300 mm	1000906
1	DC Power Supply 0 – 20 V, 0 – 5 A (230 V, 50/60 Hz)	1003312 or
	DC Power Supply 0 – 20 V, 0 – 5 A (115 V, 50/60 Hz)	1003311
1	Digital Multimeter P1035	1002781
1	Inclination and Declination Instrument	1006799
1	Rheostat 100 Ω	1003066
1	Set of 15 Safety Experiment Leads, 75 cm	1002843

2

BASIC PRINCIPLES

The earth is surrounded by a magnetic field generated by a so-called geo-dynamo effect. Close to the surface of the earth, this field resembles that of a magnetic dipole with field lines emerging from the South Pole of the planet and circling back towards the North Pole. The angle between the actual magnetic field of the earth and the horizontal at a given point on the surface is called the inclination. The horizontal component of the Earth's field roughly follows a line running between geographical north and south. Because the earth's crust exhibits magnetism itself, there are localised differences which are characterised by the term declination.

This experiment involves measuring the inclination and the absolute magnitude of the Earth's magnetic field along with the horizontal and vertical components of it at the point where the measurement is made.

The following relationships apply:

$$(1) \quad B_v = B_h \cdot \tan \alpha$$

α : inclination
 B_h : horizontal component
 B_v : vertical component

and

$$(2) \quad B = \sqrt{B_h^2 + B_v^2}$$

It is therefore sufficient to determine the values B_h and α , since the other values can simply be calculated.

The inclination α is determined with the aid of a dip needle. In order to obtain the horizontal component B_h , the dip needle is aligned in horizontal plane in such a way that its needle points to 0° when parallel to the horizontal component 0° . An additional horizontal magnetic field B_{HH} , which is perpendicular to B_h , is generated by a pair of Helmholtz coils and this field causes the compass needle to turn by an angle β . According to Fig. 1 the following is then true:

$$(3) \quad \frac{B_{HH}}{B_h} = \tan \beta.$$

In order to improve the accuracy, this measurement is carried out for a variety of angles β .

EVALUATION

From equation (3) the following can be deduced:

$$B_{HH} = B_h \cdot \tan \beta.$$

The horizontal component B_h is therefore equivalent to the gradient of a line through points plotted on a graph of B_{HH} against $\tan \alpha$. The magnetic field of the Helmholtz coils B_{HH} can be determined easily. Inside the pair of coils it is highly uniform and is proportional to the current I through either of the coils:

$$B_{HH} = k \cdot I \text{ with}$$

$$k = \left(\frac{4}{5}\right)^{\frac{3}{2}} \cdot 4\pi \cdot 10^{-7} \frac{\text{Vs}}{\text{Am}} \cdot \frac{N}{R}$$

$N = 124$: number of windings, $R = 147,5 \text{ mm}$: radius

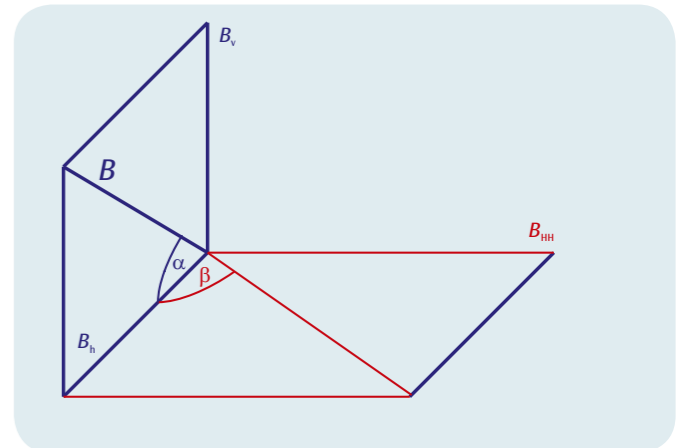

Fig. 1: Diagram of components of the magnetic fields observed in the experiment and definition of the corresponding angles

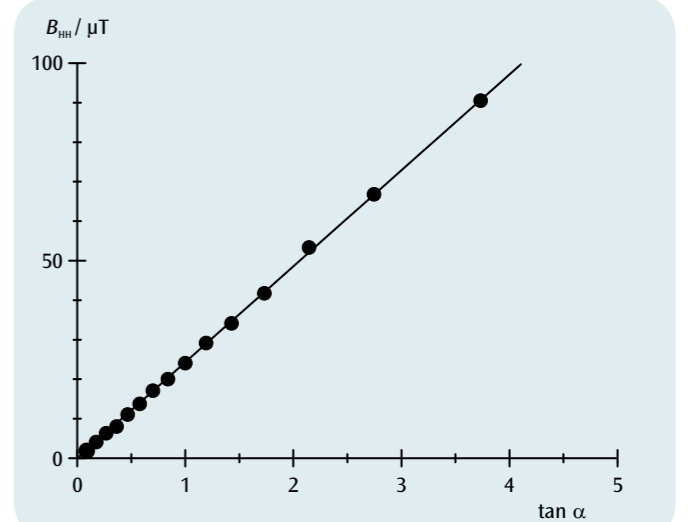
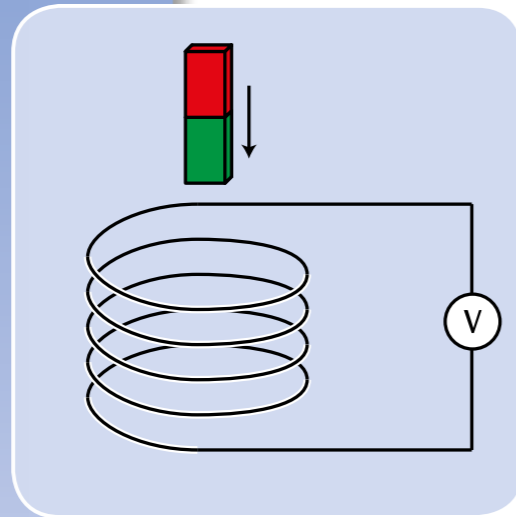

Fig. 2: $B_{HH} - \tan \alpha$ -graph to determine the horizontal component of the earth's magnetic field



OBJECTIVE

Generating a voltage pulse in a conducting loop by the motion of a permanent magnet

SUMMARY

When a permanent bar magnet is allowed to fall in succession through a set of identical induction coils connected in series, a voltage is induced in each of the coils. The voltage amplitude increases from coil to coil as the magnet moves through each coil, as the velocity of the magnet increases steadily. However, the magnetic flux that is calculated by integrating over the observed voltage curve has the same value for all the coils.

REQUIRED APPARATUS

Quantity	Description	Number
1	Tube with 6 Induction Coils	1001005
1	3B NETlog™ (230 V, 50/60 Hz)	1000540 or
	3B NETlog™ (115 V, 50/60 Hz)	1000539
1	3B NETlab™	1000544
1	Pair of Safety Experimental Leads, 75cm, red/blue	1017718

EXPERIMENT PROCEDURE

- Observing the motion of a permanent bar magnet through a set of induction coils connected in series.
- Measuring the induced voltage as a function of time.
- Calculating the magnetic flux as a function of time.

2

BASIC PRINCIPLES

Any change of the magnetic flux through a closed conducting loop induces in it an electrical voltage. Such a change is produced, for example, when a permanent bar magnet moves through a stationary conducting loop.

In this case it is instructive to consider not only the time-dependent induced voltage

$$(1) \quad U(t) = -\frac{d\Phi}{dt}(t)$$

Φ : Magnetic flux

but also its integral over time, viz. the voltage pulse

$$(2) \quad \int_{t_1}^{t_2} U(t) \cdot dt = \Phi(t_1) - \Phi(t_2)$$

This corresponds to the difference between the magnetic flux at the beginning (t_1) and that at the end (t_2) of the observed process.

In the experiment, a permanent bar magnet is allowed to fall through six identical induction coils that are connected in series. The induced voltage is recorded as a function of time (see Fig. 1). The voltage amplitude increases from coil to coil as the magnet moves through each coil, because the velocity of the magnet increases steadily.

The areas under all the positive and negative voltage signals are equal. They correspond to the maximum flux Φ produced by the permanent magnet inside each individual coil.

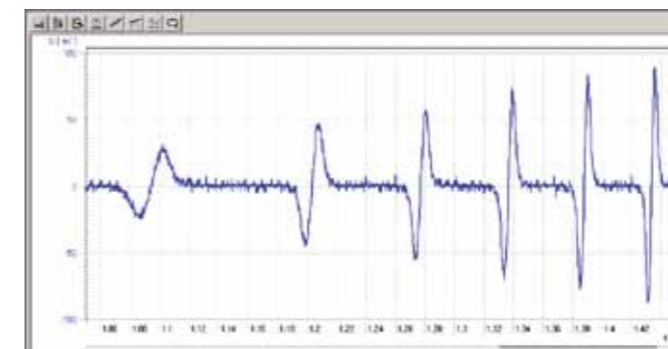

Fig. 1: Induced voltage U as a function of time

EVALUATION

The experimental set-up is such that the induced voltage is negative when the magnet is introduced into the coil.

The induced voltage is once again zero when the magnet reaches the centre of the coil, and therefore the magnetic flux has its maximum value at that point. During the subsequent exit phase of the magnet, a positive voltage is induced.

From the voltage measurements, we can calculate the magnetic flux at any point in time t by integration, using Equation 2:

$$\Phi(t) = \Phi(0) - \int_0^t U(t') \cdot dt'$$

The maximum flux reached during the magnet's fall is the same for all the coils, subject to the limitation of the precision of the measurements (see Fig. 2).

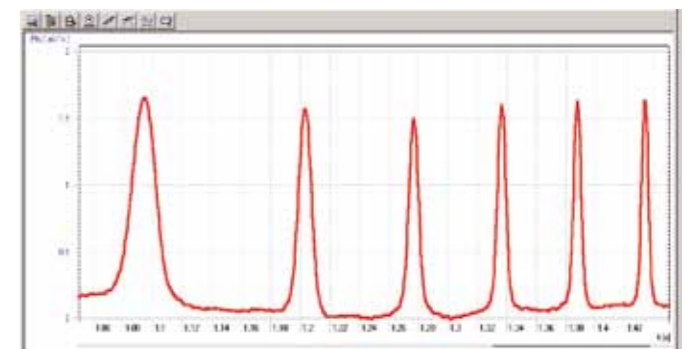
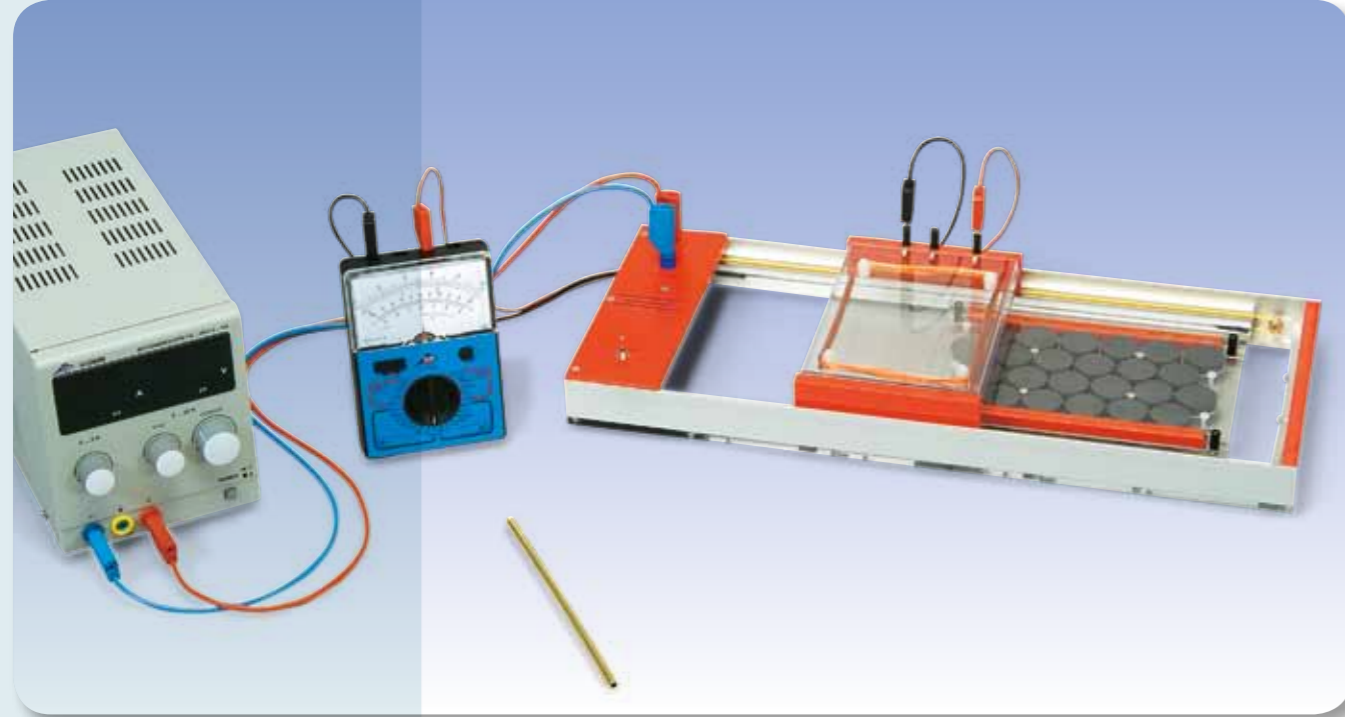

Fig. 2: Magnetic flux Φ as a function of time



EXPERIMENT PROCEDURE

- Measure the induced voltage as a function of the velocity of the conductor loop.
- Measure the induced voltage as a function of the number of turns in the conductor loop.
- Compare the sign of the induced voltage when moving the conductor loop into the field or out of it.
- Compare the sign of the induced voltage when the direction of motion is changed.
- Measure the induced voltage in a conductor loop with a single turn of variable area.

OBJECTIVE

Measure the induced voltage in a conductor made into a loop as it moves through a magnetic field

SUMMARY

The change in magnetic flux that is needed to induce a voltage in a conductor loop can be caused by a movement of the loop. Such a situation results, for example, when a conductor loop orientated with its plane perpendicular to a homogeneous magnetic field is moved into the magnetic field or withdrawn from it at a constant velocity. In the first case the magnetic flux increases at a rate determined by the relevant parameters, whereas in the second case it decreases in a similar way. Therefore the induced voltages are of opposite signs.

REQUIRED APPARATUS

Quantity	Description	Number
1	Induction Apparatus	1000968
1	DC Power Supply 0 – 20 V, 0 – 5 A (230 V, 50/60 Hz)	1003312 or
	DC Power Supply 0 – 20 V, 0 – 5 A (115 V, 50/60 Hz)	1003311
1	Analogue Multimeter AM50	1003073
1	Set of 15 Safety Experiment Leads, 75 cm	1002843
1	Mechanical Cumulative Stopwatch	1002810
Additionally recommended		
1	Measurement Amplifier (230 V, 50/60 Hz)	1001022 or
	Measurement Amplifier (115 V, 50/60 Hz)	1001021

1

BASIC PRINCIPLES

The term **electromagnetic induction** refers to the process whereby an electric voltage is generated around a conductor loop when the magnetic flux passing through the loop is changed. Such a change in flux can result from a change in the magnetic field strength or from movement of the conductor loop.

To describe the relationships involved, a U-shaped conductor loop with a moveable crossbar is often considered. The plane of this loop is aligned perpendicular to a homogeneous magnetic field of flux density B (see Fig. 1). The magnetic flux through the area limited by the cross-bar is

$$(1) \quad \Phi = B \cdot a \cdot b$$

a : Width, b : Length of the loop.

If the cross-bar is moved with a velocity v , the flux changes, since the length of the loop is changed. The rate of change of the flux is

$$(2) \quad \frac{d\Phi}{dt} = B \cdot a \cdot v$$

and in the experiment it is observed as a voltage

$$(3) \quad U = -B \cdot a \cdot v$$

which is in the order of microvolts but can be measured using the amplifier that is recommended as additional equipment.

A much greater induced voltage is obtained if a conducting loop with multiple turns on a rigid frame is moved through the magnetic field. When the frame is only partly projecting into the magnetic field, the situation is as shown schematically in Figure 1. The movement of the loop into the magnetic field results in a change of flux at the following rate

$$(4) \quad \frac{d\Phi_1}{dt} = B \cdot N \cdot a \cdot v$$

N : Number of turns,

and this can be measured as an induced voltage.

$$(5) \quad U_1 = -B \cdot N \cdot a \cdot v$$

As soon as the conductor loop is completely in the magnetic field, the induced voltage returns to zero. No further change occurs until the loop begins to move out of the magnetic field. Now the magnetic flux is decreasing and the induced voltage is of opposite sign compared with the initial situation. A change of sign also occurs if the direction of motion of the loop is reversed.

In this experiment, the voltage driving an electric motor used to pull the conductor loop along is varied. This provides a range of different constant velocities. The direction of rotation of the motor can also be reversed. The coil provided also has an intermediate tapping point, so that the induced voltage can be measured for three different values of N , the number of turns.

EVALUATION

Calculate the velocity from the time t required for the conductor loop to move completely through the magnetic field and the corresponding distance L

$$v = \frac{L}{t}$$

Then draw a graph of the induced voltage U as a function of the velocity v . The data will be found to lie on a straight line through the origin (see Fig. 2).

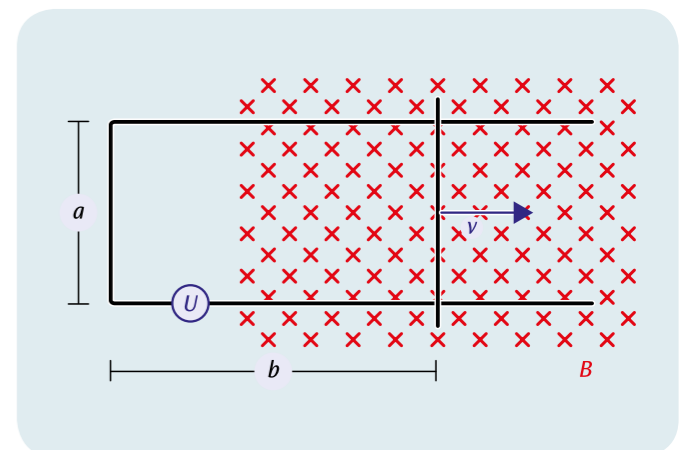

Fig. 1: The change of the magnetic flux through the conducting loop when its area is altered

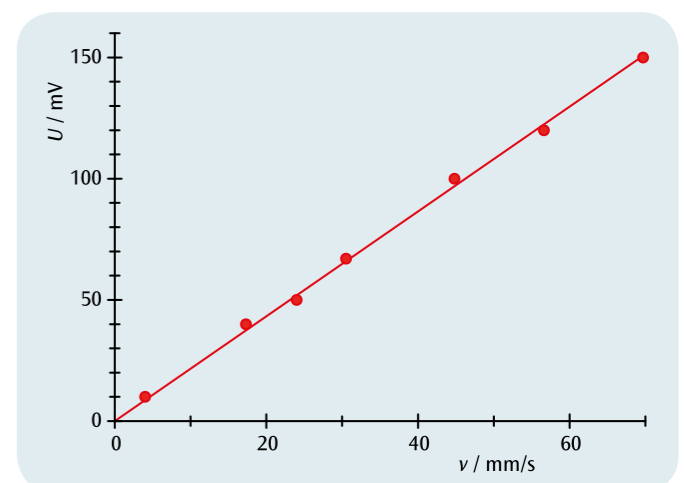

Fig. 2: Induced voltage as a function of the velocity of the conducting loop



EXPERIMENT PROCEDURE

- Investigate the braking of a Waltenhofen pendulum due to eddy currents in a uniform magnetic field.
- Demonstrate the suppression of eddy currents in a disc with slots.

1

REQUIRED APPARATUS

Quantity	Description	Number
1	Waltenhofen's Pendulum	1000993
1	Tripod Stand 150 mm	1002835
1	Stainless Steel Rod 750 mm	1002935
1	Universal Clamp	1002830
1	DC Power Supply 0 – 20 V, 0 – 5 A (230 V, 50/60 Hz)	1003312 or
	DC Power Supply 0 – 20 V, 0 – 5 A (115 V, 50/60 Hz)	1003311
1	U Core	1000979
1	Pair of Pole Shoes	1000978
1	Pair of Clamps	1000977
2	Coil D with 1200 Taps	1000989
1	Set of 15 Safety Experiment Leads, 75 cm	1002843

OBJECTIVE

Demonstrate and investigate how an eddy-current brake works

SUMMARY

In a metal disc moving through a uniform magnetic field, eddy currents get induced. The uniform magnetic field exerts a force due to these currents that causes the disc to slow down.

BASIC PRINCIPLES

When a metal disc moves through a uniform magnetic field each section of the disc experiences constantly changing magnetic flux and an eddy voltage is induced therein. This causes electrical eddy currents to flow all over the disc. These are subject to Lorentz forces within the magnetic field that act to slow down the motion of the disc. These eddy currents are drastically reduced if the metal disc has slots in it. This means that the current has to flow from one segment to the next by a more circuitous route. Such a disc is slowed down only slightly.

The emergence and suppression of eddy currents can be clearly demonstrated using a Waltenhofen pendulum. This includes a partially slotted metal disc that oscillates inside a uniform magnetic field.

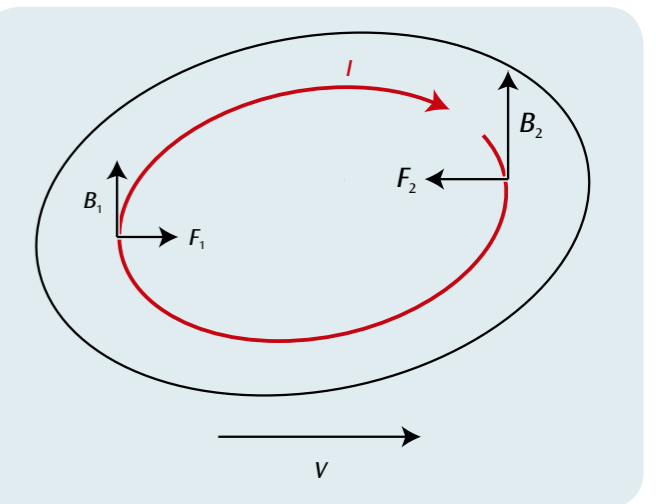

Eddy current I in a metal disc moving at speed v through a uniform magnetic field B_1, B_2 with Lorentz forces F_1 and F_2 acting on both limbs of the eddy. The force acting against the motion is greater than that operating in the same direction.

EVALUATION

When a metal disc without slots moves through the uniform magnetic field, its oscillation is damped. The damping increases with the magnitude of the magnetic field. Eddy currents are induced within the disc and the magnetic field itself exerts a force as a result that opposes the motion (cf. Lenz's law).

If the slotted disc moves through the field, the damping of the motion is only slight since it is much more difficult for the eddy currents to form.



EXPERIMENT PROCEDURE

- Measure the voltage across the secondary coil as a function of the voltage across the primary with no load for a fixed number of windings.
- Measure the current in the primary coil as a function of the current in the secondary with a fixed number of windings and a short-circuited output.
- Measure the primary voltage, the primary current, the secondary voltage and the secondary current, for a specific load resistance.
- Determine the power loss and the efficiency.

OBJECTIVE

Make measurements on a transformer with and without load

SUMMARY

Transformers are devices based on Faraday's law of induction which are used for converting voltages. One major use is for the transmission of electrical power over large distances, whereby power losses can be minimised by converting the voltage up to the highest possible levels thus reducing the current to a minimum. This experiment investigates the way the voltage and current depend on the number of windings with and without a load and with the output short-circuited. You will also calculate the power losses and efficiency.

REQUIRED APPARATUS

Quantity	Description	Number
2	Low Voltage Coil D	1000985
1	Transformer Core D	1000976
1	AC/DC Power Supply 1/ 2/ 3/ ... 15 V, 10 A (230 V, 50/60 Hz)	1008691 or
	AC/DC Power Supply 1/ 2/ 3/ ... 15 V, 10 A (115 V, 50/60 Hz)	1008690
3	Digital Multimeter P3340	1002785
1	Rheostat 10 Ω	1003064
1	Two-pole Switch	1018439
1	Set of 15 Safety Experiment Leads, 75 cm	1002843

BASIC PRINCIPLES

Transformers are devices based on Faraday's law of induction which are used for converting voltages. One major use is for the transmission of electrical power over large distances, whereby power losses can be minimised by converting the voltage up to the highest possible levels thus reducing the current to a minimum.

2

The simplest form of transformer consists of two coils coupled together, a primary coil with N_1 winding turns and a secondary coil with N_2 winding turns, both of which are wound around a common iron core. This means that the magnetic flux Φ_1 resulting from the current I_1 flowing in the primary coil fully surrounds the secondary coil.

The following treatment considers an ideal, i.e. loss-free, transformer. When there is no load on the transformer, no current flows in the secondary, i.e. $I_2 = 0$. If an alternating voltage U_1 is applied to the primary coil, a no-load or open-circuit current I_1 flows, thereby generating a magnetic flux Φ_1 and inducing a voltage U_{ind} . Kirchhoff's 2nd law implies that this induced voltage is opposite to and equal to U_1 since $(U_1 + U_{\text{ind}} = 0)$:

$$(1) \quad U_{\text{ind}} = -L_1 \cdot \frac{dI_1}{dt} = -N_1 \cdot \frac{d\Phi_1}{dt} = -U_1$$

L_1 : inductance of primary coil
 Φ_1 : magnetic flux generated by I_1

Since the magnetic flux Φ_1 completely encompasses the secondary coil, a voltage is induced there:

$$(2) \quad U_2 = -N_2 \cdot \frac{d\Phi_1}{dt}$$

Equations (1) and (2) then lead to the following conclusion:

$$(3) \quad \frac{U_2}{U_1} = -\frac{N_2}{N_1}$$

The negative sign indicates that U_1 and U_2 are phase-shifted by 180° when the windings are in the same direction. If the windings are wound the opposite way round, the voltages will be in phase.

When there is a load on the transformer, a current $I_2 = U_2 / R$ flows in the secondary coil. R is the resistance of the load. This current gives rise to a magnetic flux Φ_2 which, according to Lenz's law, is opposed to the magnetic flux Φ_1 generated by the primary current I_1 . Since the primary voltage U_1 remains constant, the primary current I_1 therefore increases. In the ideal case, the power output of the secondary coil P_2 is equal to the power input to the primary P_1 :

$$(4) \quad P_1 = U_1 \cdot I_1 = U_2 \cdot I_2 = P_2$$

Combining this with equation (3) the following results:

$$(5) \quad \frac{I_1}{I_2} = \frac{N_2}{N_1}$$

The first part of the experiment involves connecting a voltmeter to the secondary side of the transformer and measuring the secondary voltage U_{20} as a function of the primary voltage U_{10} without any load (hence $I_{20} = 0$). The ratio of the number of coil windings remains fixed at $N_1/N_2 = 1/2$. Then the secondary side is shorted through an ammeter (such that $U_{2c} = 0$) and the primary current I_{1c} is measured as a function of the secondary current I_{2c} , again for a fixed winding ratio $N_1/N_2 = 1/2$. Finally a load resistor $R = 2 \Omega$ is connected across the secondary and the primary voltage U_1 , primary current I_1 , secondary voltage U_2 and secondary current I_2 are all measured, still with a fixed winding ratio $N_1/N_2 = 1/2$.

EVALUATION

From equation (3) it follows for the voltages that

$$U_2 = \frac{N_2}{N_1} \cdot U_1$$

and from equation (5) correspondingly for the currents that

$$I_1 = \frac{N_2}{N_1} \cdot I_2$$

Consequently, the linear gradients found in the diagrams in Figures 2 and 3 are determined by the ratio of the number of windings.

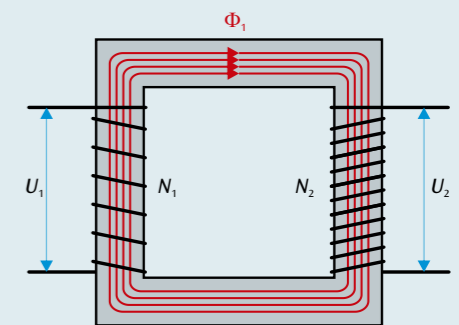

Fig. 1: Schematic depiction of the transformer

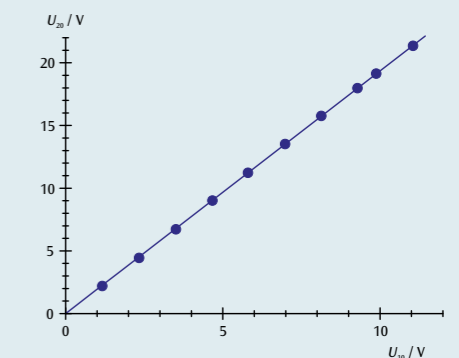

Fig. 2: Secondary voltage U_{20} as a function of primary voltage U_{10} with no load ($I_{20} = 0$), $N_1 = 36$, $N_2 = 72$

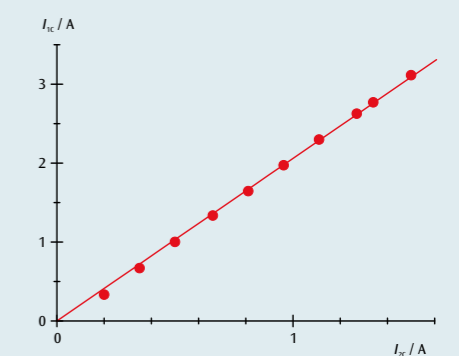
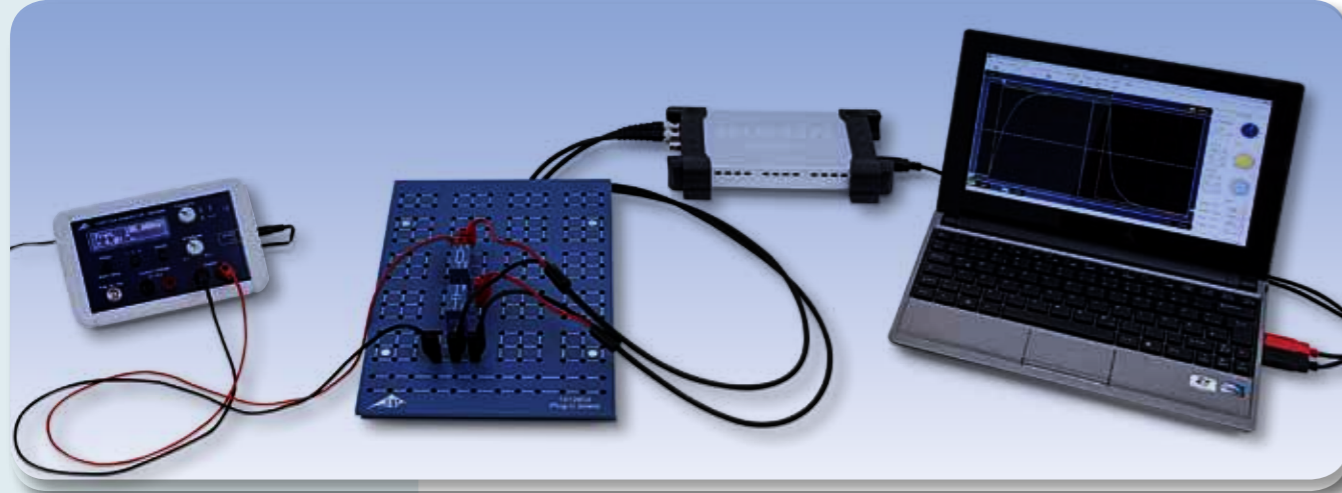

Fig. 3: Primary current I_{1c} as a function of secondary current I_{2c} with short-circuited secondary ($U_{2c} = 0$), $N_1 = 36$, $N_2 = 72$



EXPERIMENT PROCEDURE

- Measure the voltage across a capacitor as it charges and discharges when the DC supply voltage to a circuit is turned on and off.
- Determine the half-life period for charging and discharging.
- Investigate how the half-life period depends on the capacitance and the resistance.

OBJECTIVE

Investigation of how the voltage across a capacitor changes over time when the capacitor is charging or discharging

SUMMARY

In a DC circuit, current only flows through a capacitor at the point in time when the power is turned on or off. The current causes the capacitor to charge up until the voltage across it is equal to the voltage applied. When the power is switched off, the capacitor will discharge till the voltage across it drops to zero. A plot of the capacitor voltage against time can be shown as an exponential curve, i.e. the voltage drops by half in the space of a fixed period $T_{1/2}$ called the half-life. The same period elapses when the voltage drops from a half to a quarter and from a quarter to an eighth. The half-life period is proportional to the capacitance and the resistance through which the capacitor discharges.

REQUIRED APPARATUS

Quantity	Description	Number
1	Plug-In Board for Components	1012902
1	Resistor 470 Ω , 2 W, P2W19	1012914
1	Resistor 1 k Ω , 2 W, P2W19	1012916
1	Resistor 2.2 k Ω , 2 W, P2W19	1012918
3	Capacitor 1 μ F, 100 V, P2W19	1012955
1	Function Generator FG 100 (230 V, 50/60 Hz)	1009957 or
	Function Generator FG 100 (115 V, 50/60 Hz)	1009956
1	USB Oscilloscope 2x50 MHz	1017264
2	HF Patch Cord, BNC/4 mm Plug	1002748
1	Set of 15 Experiment Leads, 75 cm 1 mm ²	1002840
1	Set of 10 Jumpers, P2W19	1012985

1

BASIC PRINCIPLES

In a DC circuit, current only flows through a capacitor at the point in time when the power is turned on or off. The current causes the capacitor to charge up until the voltage across it is equal to the voltage applied. When the power is switched off, the capacitor will discharge till the voltage across it drops to zero. A plot of the capacitor voltage against time can be shown as an exponential curve.

For a DC circuit featuring a capacitance C , resistance R and a DC voltage U_0 , the following applies when the supply is turned on:

$$(1) \quad U(t) = U_0 \cdot \left(1 - e^{-\frac{t \ln 2}{T_{1/2}}}\right)$$

The following applies when the power supply is switched off:

$$(2) \quad U(t) = U_0 \cdot e^{-\frac{t \ln 2}{T_{1/2}}}$$

where

$$(3) \quad T_{1/2} = \ln 2 \cdot R \cdot C$$

$T_{1/2}$ is the half-life period, i.e. the voltage across the a discharging capacitor will halve within a time $T_{1/2}$. The same period elapses when the voltage drops from a half to a quarter and from a quarter to an eighth.

These aspects will be investigated in the experiment. How the capacitor voltage changes over time is recorded using a storage oscilloscope. Since the DC voltage U_0 is set to 8 V, it is easy to read off a half, a quarter and an eighth of that value.

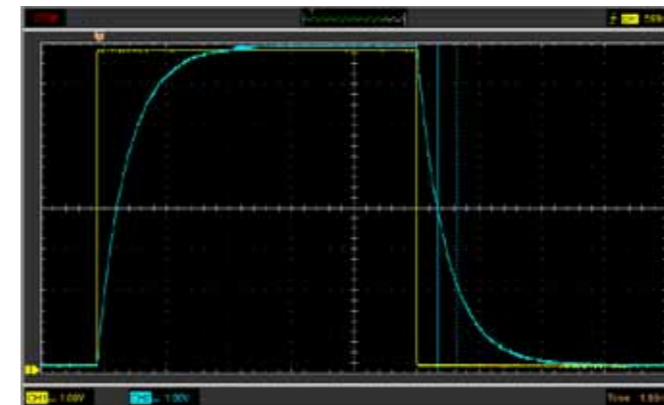

Fig. 1: Traces of voltage across a capacitor while charging and discharging recorded with an oscilloscope

EVALUATION

The fact that the results measured for the length of the half-life over the various sections of the charging and discharging traces all match verifies that the curve is of the expected exponential nature, see (1) and (2). Plots of the half-life periods measured as a function of the resistance and of the capacitance show that they can fit along a straight line through the origin in either case, see (3).

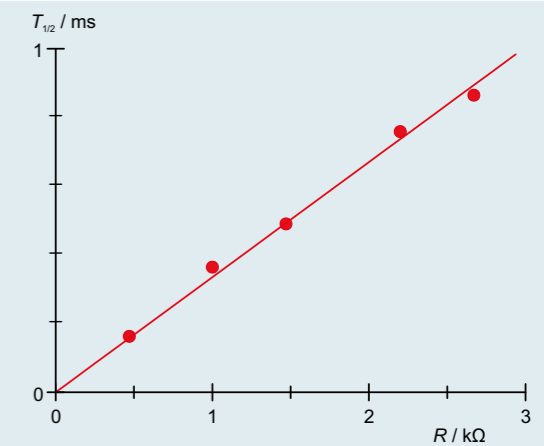

Fig. 2: Half-life $T_{1/2}$ as a function of resistance R

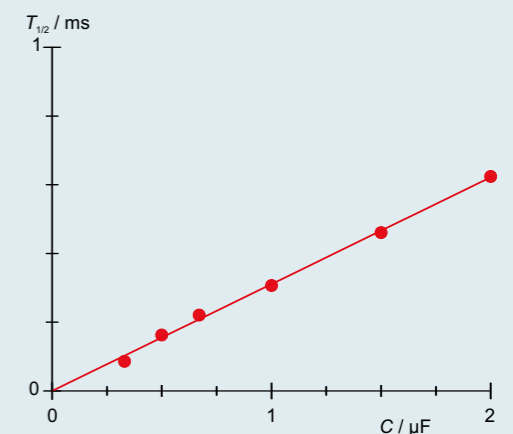

Fig. 3: Half-life $T_{1/2}$ as a function of capacitance C

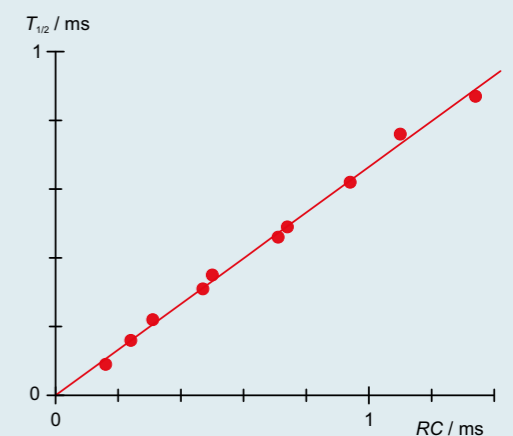

Fig. 4: Half-life $T_{1/2}$ as a function of the product of $R \cdot C$



EXPERIMENT PROCEDURE

- Record the change in the capacitor voltage over time while a capacitor is charging by measuring the time taken to reach specific points.
- Record the change in the capacitor voltage over time while a capacitor is discharging by measuring the time taken to reach specific points.
- Determine resistance and capacitance by measuring the times it takes to charge and discharge and make a comparison with known external parameters.

OBJECTIVE

Determine the charging and discharging times

SUMMARY

The discharge curve of a capacitor is to be derived by measuring the times taken for certain voltages to be reached to obtain sample points. The charging curve is to be measured in the same way. The measurements will then be used to determine data regarding the resistors and capacitors being used.

REQUIRED APPARATUS

Quantity	Description	Number
1	Charge and Discharge Apparatus (230 V, 50/60 Hz)	1017781 or
	Charge and Discharge Apparatus (115 V, 50/60 Hz)	1017780
1	Capacitor 1000 μF , 16 V, P2W19	1017806
1	Resistor 10 k Ω , 0.5 W, P2W19	1012922
Additionally required:		
1	Digital Multimeter P1035	1002781

1

BASIC PRINCIPLES

In a DC circuit, current only flows through a capacitor while it is being turned on or off. The current causes the capacitor to charge when the circuit is switched on until it reaches the full voltage applied. When the circuit is turned off, the capacitor is discharged until its voltage falls to zero.

For a DC circuit with capacitance C , resistance R and DC voltage U_0 , the following applies when the circuit is switched on:

$$(1) \quad U(t) = U_0 \cdot (1 - e^{-\frac{t}{\tau}})$$

The following applies when the circuit is switched off:

$$(2) \quad U(t) = U_0 \cdot e^{-\frac{t}{\tau}}$$

In both cases the time constant is

$$(3) \quad \tau = R \cdot C$$

To check these relationships, the time to reach certain pre-determined comparison voltages is measured during the course of the experiment. A stopwatch is started at the same time as the circuit is switched on or off and then stopped by means of a comparator circuit once the comparison voltage has been reached. By measuring the times for various comparison voltages, the charging and discharging curves can be sampled and plotted point by point.

In practice, the following time is also of interest:

$$(4) \quad t_{5\%} = -\ln(5\%) \cdot R \cdot C \approx 3 \cdot R \cdot C$$

This is the time it takes for the capacitor voltage to reach 5% of the initial voltage U_0 during discharge or to reach within 5% of the final value U_0 when charging. By measuring $t_{5\%}$ it is possible to determine the parameters R and C , for example.

EVALUATION

For a known external resistance R_{ext} , the external capacitance C_{ext} can be calculated using the time $t_{5\%}$ by means of Equation (4):

$$C_{\text{ext}} = \frac{t_{5\%}}{3 \cdot R_{\text{ext}}}$$

The external capacitance determined in this way will be connected in parallel with the internal capacitance C_{int} in order to determine the latter by comparing the charging and discharging times.

Finally the three remaining unknown internal resistances $R_{\text{int},i}$ can be obtained from the relevant charging and discharging times:

$$R_{\text{int},i} = \frac{t_{5\%,i}}{3 \cdot C_{\text{int}}} \quad \text{where } i = 1, 2, 3$$

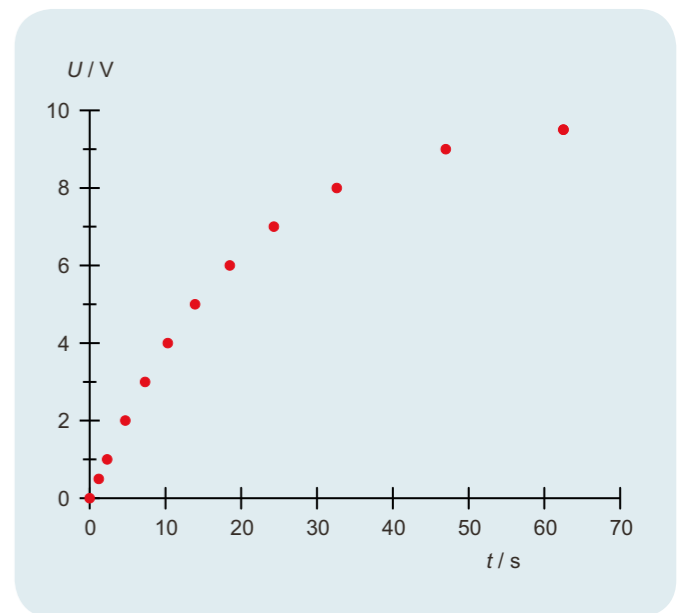

Fig. 1: Charging curve for internal RC pair

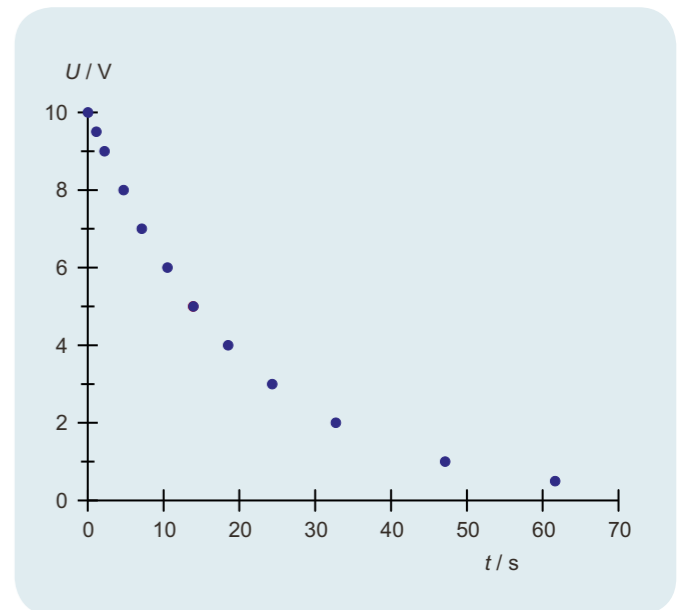
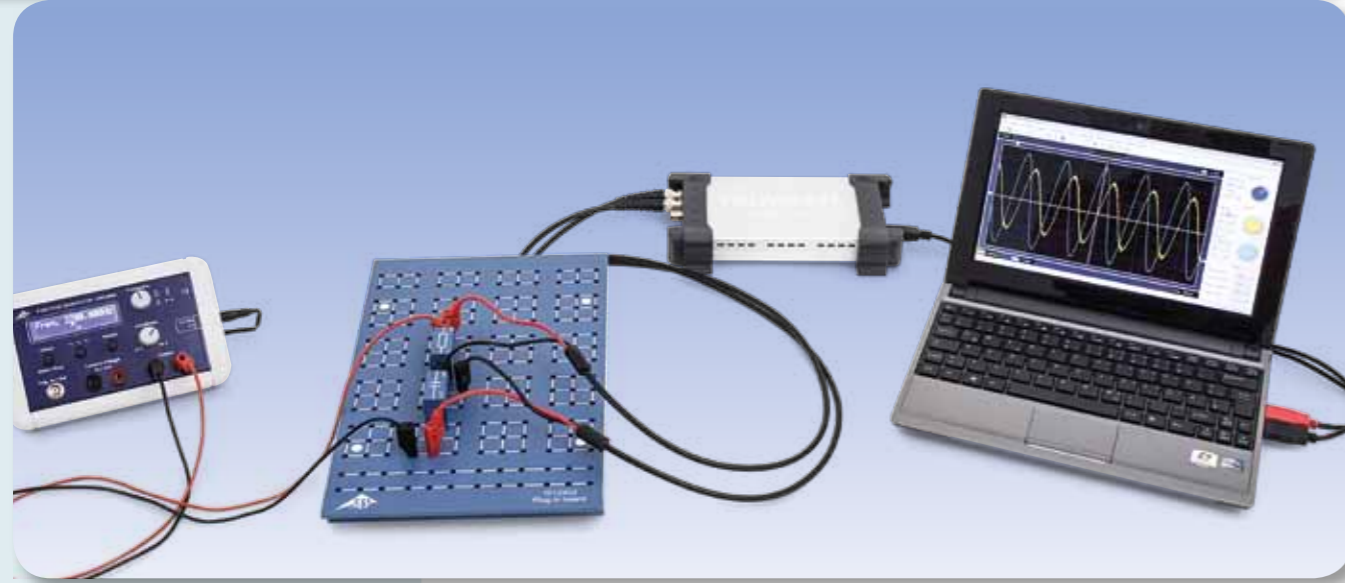

Fig. 2: Discharging curve for internal RC pair



EXPERIMENT PROCEDURE

- Determine the amplitude and phase of capacitive impedance as a function of the capacitance.
- Determine the amplitude and phase of capacitive impedance as a function of the frequency.

OBJECTIVE

Determine the impedance of a capacitor as a function of capacitance and frequency

SUMMARY

Any change in voltage across a capacitor gives rise to a flow of current through the component. If an AC voltage is applied, alternating current will flow which is shifted in phase with respect to the voltage. In this experiment, a frequency generator supplies an alternating voltage with a frequency of up to 3 kHz. A dual-channel oscilloscope is used to record the voltage and current, so that the amplitude and phase of both can be determined. The current through the capacitor is given by the voltage drop across a resistor with a value which is negligible in comparison to the impedance exhibited by the capacitor itself.

REQUIRED APPARATUS

Quantity	Description	Number
1	Plug-In Board for Components	1012902
1	Resistor 1 Ω, 2 W, P2W19	1012903
1	Resistor 10 Ω, 2 W, P2W19	1012904
3	Capacitor 1 μF, 100 V, P2W19	1012955
1	Capacitor 0.1 μF, 100 V, P2W19	1012953
1	Function Generator FG 100 (230 V, 50/60 Hz)	1009957 or
	Function Generator FG 100 (115 V, 50/60 Hz)	1009956
1	USB Oscilloscope 2x50 MHz	1017264
2	HF Patch Cord, BNC/4 mm Plug	1002748
1	Set of 15 Experiment Leads, 75 cm 1 mm ²	1002840

2

BASIC PRINCIPLES

Any change in voltage across a capacitor gives rise to a flow of current through the component. If an AC voltage is applied, alternating current will flow which is shifted in phase with respect to the voltage. In mathematical terms, the relationship can be expressed most easily if current, voltage and impedance are regarded as complex values, whereby the real components need to be considered.

The capacitor equation leads directly to the following:

$$(1) \quad I = C \cdot \frac{dU}{dt}$$

I: Current, *U*: Voltage, *C*: Capacitance

Assume the following voltage is applied:

$$(2) \quad U = U_0 \cdot \exp(i \cdot 2\pi \cdot f \cdot t)$$

This gives rise to a current as follows:

$$(3) \quad I = i \cdot \omega \cdot C \cdot U_0 \cdot \exp(i \cdot 2\pi \cdot f \cdot t)$$

Capacitor *C* is then assigned the complex impedance

$$(4) \quad X_c = \frac{U}{I} = \frac{1}{i \cdot 2\pi \cdot f \cdot C}$$

The real component of this is measurable, therefore

$$(5a) \quad U = U_0 \cdot \cos \omega t$$

$$(6a) \quad I = 2\pi \cdot f \cdot C \cdot U_0 \cos \left(\omega t + \frac{\pi}{2} \right) \\ = I_0 \cos \left(\omega t + \frac{\pi}{2} \right)$$

$$(7a) \quad X_c = \frac{U_0}{I_0} = \frac{1}{2\pi \cdot f \cdot C}$$

In this experiment, a frequency generator supplies an alternating voltage with a frequency of up to 3 kHz. A dual-channel oscilloscope is used to record the voltage and current, so that the amplitude and phase of both can be determined. The current through the capacitor is related to the voltage drop across a resistor with a value which is negligible in comparison to the impedance exhibited by the capacitor itself.

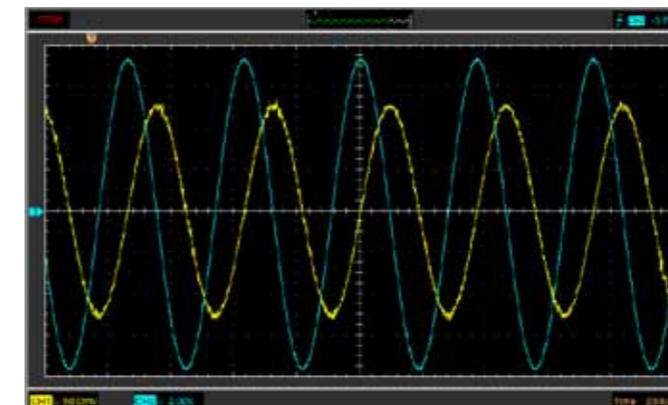

Fig. 1: Capacitor in AC circuit: trace of voltage and current

EVALUATION

The capacitive impedance X_c is proportional to the inverse of the frequency f and the inverse of the capacitance C . In the relevant graphs, the measurements therefore lie along a straight line through the origin within the measurement tolerances.

The phase of the current is 90° ahead of that for the voltage, since charging current (positive sign) and discharge current (negative sign) reach their maxima when the voltage passes through zero.

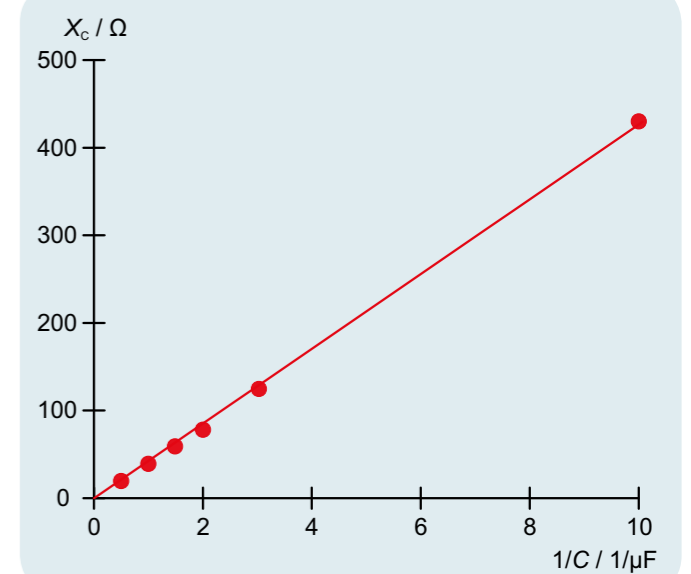

Fig. 2: Capacitive impedance X_c as a function of the inverse of the capacitance C

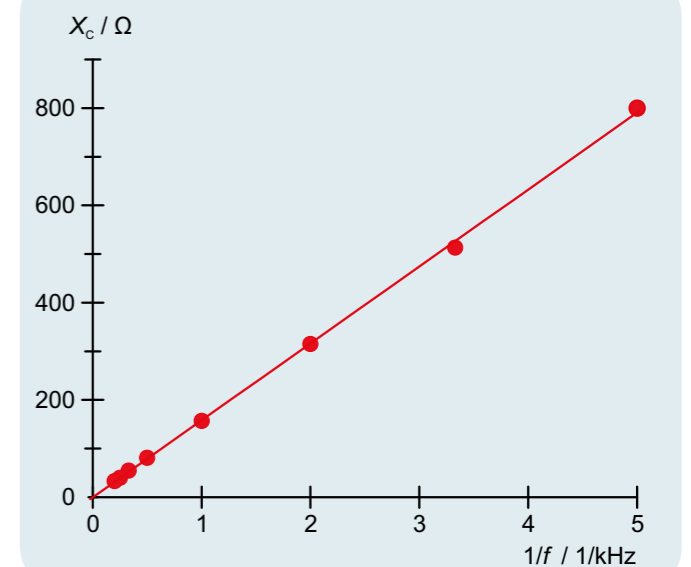
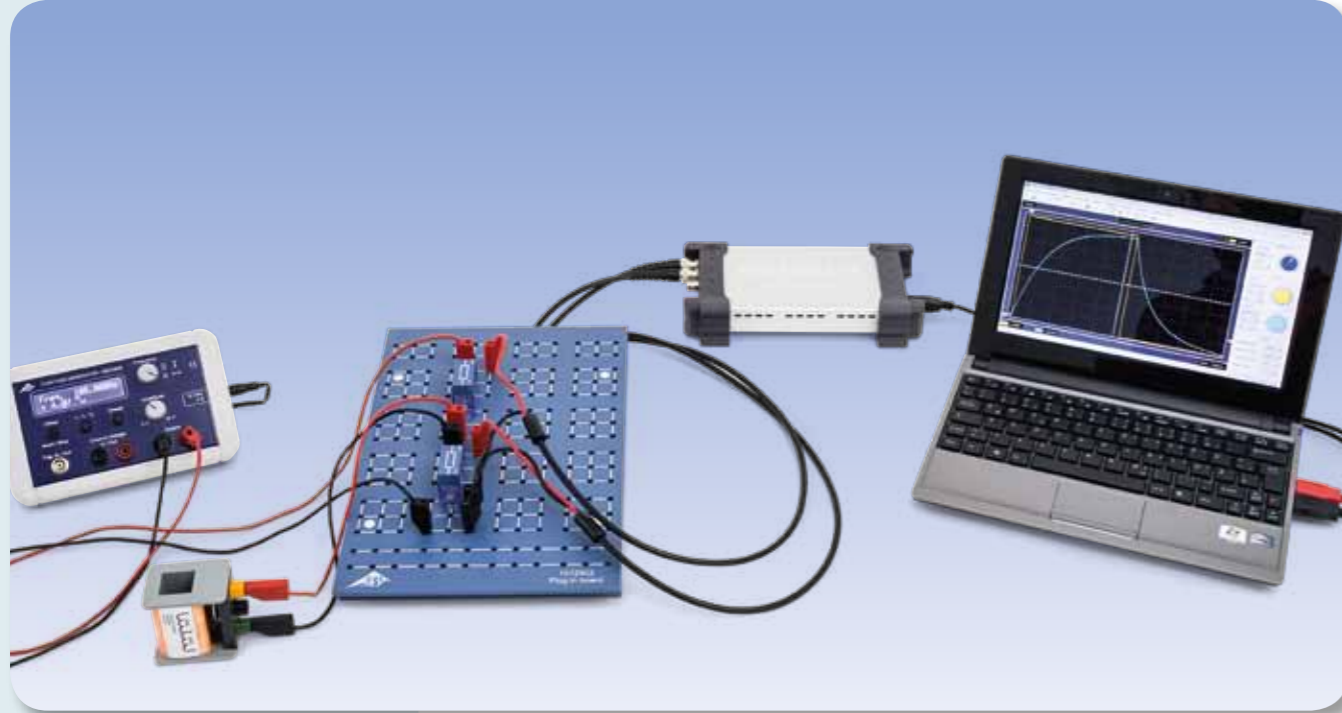

Fig. 3: Capacitive impedance X_c as a function of the inverse of the frequency f



EXPERIMENT PROCEDURE

- Measure the current in a coil when a DC supply is turned on and when it is turned off.
- Determine the half-life period when a DC supply is turned on and when it is turned off.
- Investigate how the half-life depends on inductance and resistance.

OBJECTIVE

Investigation of how the current through a coil changes over time when the DC supply is turned on and off

SUMMARY

The behaviour of a coil in a DC circuit changes as soon as the DC supply is turned on or off. The change in current is delayed by self-induction of the coil until it reaches its final value when turning on or zero when turning off. A plot of the coil current against time can be shown to be an exponential curve, i.e. the current through the coil drops by half in the space of a fixed period $T_{1/2}$ called the half-life. The same period elapses when the current drops from a half to a quarter and from a quarter to an eighth. The half-life period is proportional to the inductance and the resistance of the circuit.

REQUIRED APPARATUS

Quantity	Description	Number
1	Plug-In Board for Components	1012902
1	Resistor 1 Ω , 2 W, P2W19	1012903
1	Resistor 10 Ω , 2 W, P2W19	1012904
1	Resistor 22 Ω , 2 W, P2W19	1012907
1	Resistor 47 Ω , 2 W, P2W19	1012908
1	Resistor 150 Ω , 2 W, P2W19	1012911
1	Set of 10 Jumpers, P2W19	1012985
2	Coil S with 1200 Taps	1001002
1	Function Generator FG 100 (230 V, 50/60 Hz)	1009957 or
1	Function Generator FG 100 (115 V, 50/60 Hz)	1009956
1	USB Oscilloscope 2x50 MHz	1017264
2	HF Patch Cord, BNC/4 mm Plug	1002748
1	Set of 15 Experiment Leads, 75 cm 1 mm ²	1002840

1

BASIC PRINCIPLES

The behaviour of a coil in a DC circuit changes as soon as the DC supply is turned on or off. The change in current is delayed by self-induction of the coil until it reaches its final value when turning on or zero when turning off. A plot of the coil current against time can be shown to be an exponential curve.

For a DC circuit featuring an inductance L , resistance R and DC voltage U_0 , the following applies when the supply is switched on:

$$(1) \quad I(t) = I_0 \cdot (1 - e^{-\frac{t \ln 2}{T_{1/2}}})$$

The following applies when the power is supply off:

$$(2) \quad I(t) = I_0 \cdot e^{-\frac{t \ln 2}{T_{1/2}}}$$

where

$$(3) \quad T_{1/2} = \ln 2 \cdot \frac{L}{R}$$

$T_{1/2}$ is the half-life period, i.e. the current through the coil will halve within a time $T_{1/2}$. The same period elapses when the current drops from a half to a quarter and from a quarter to an eighth.

These aspects will be investigated in the experiment. How the coil current changes over time is recorded using a storage oscilloscope. The current is measured by means of the voltage drop across a resistor R_M . The current I_0 has been selected such that a half, a quarter and an eighth of this current are easy to read off.

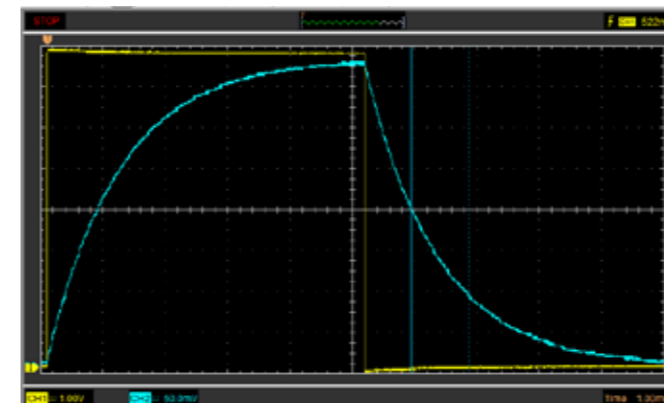

Fig. 1: Traces of current through a coil while charging and discharging recorded with an oscilloscope

EVALUATION

The fact that the measured results for the length of the half-life over the various sections of the charging and discharging traces all match verifies that the curve is of the expected exponential nature, see (1) and (2). Plots of the half-life periods measured as a function of the resistance and of the inductance shows that they can fit along a straight line through the origin in either case, see (3).

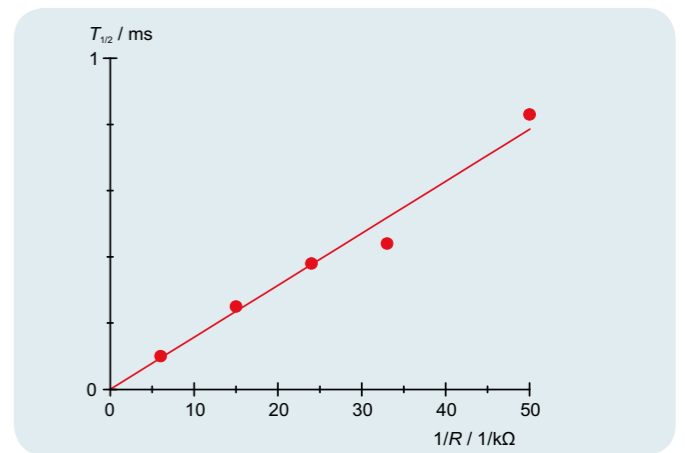

Fig. 2: Half-life $T_{1/2}$ as a function of the inverse of resistance R

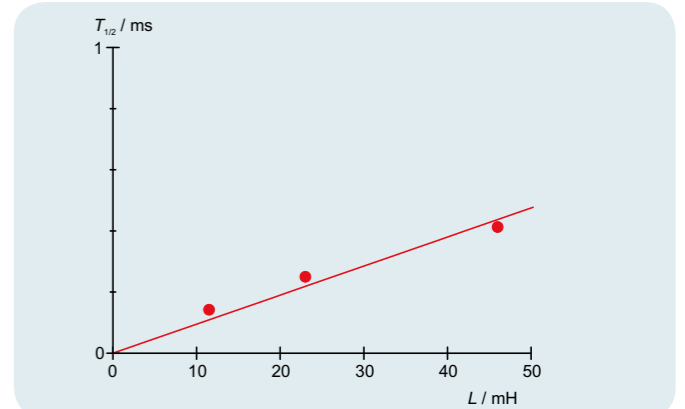

Fig. 3: Half-life $T_{1/2}$ as a function of inductance L

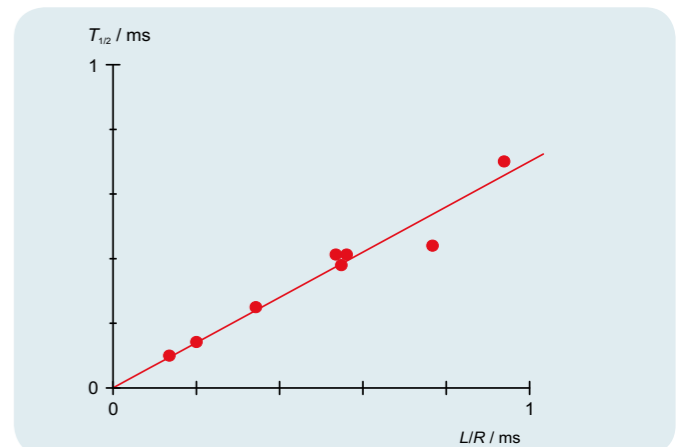
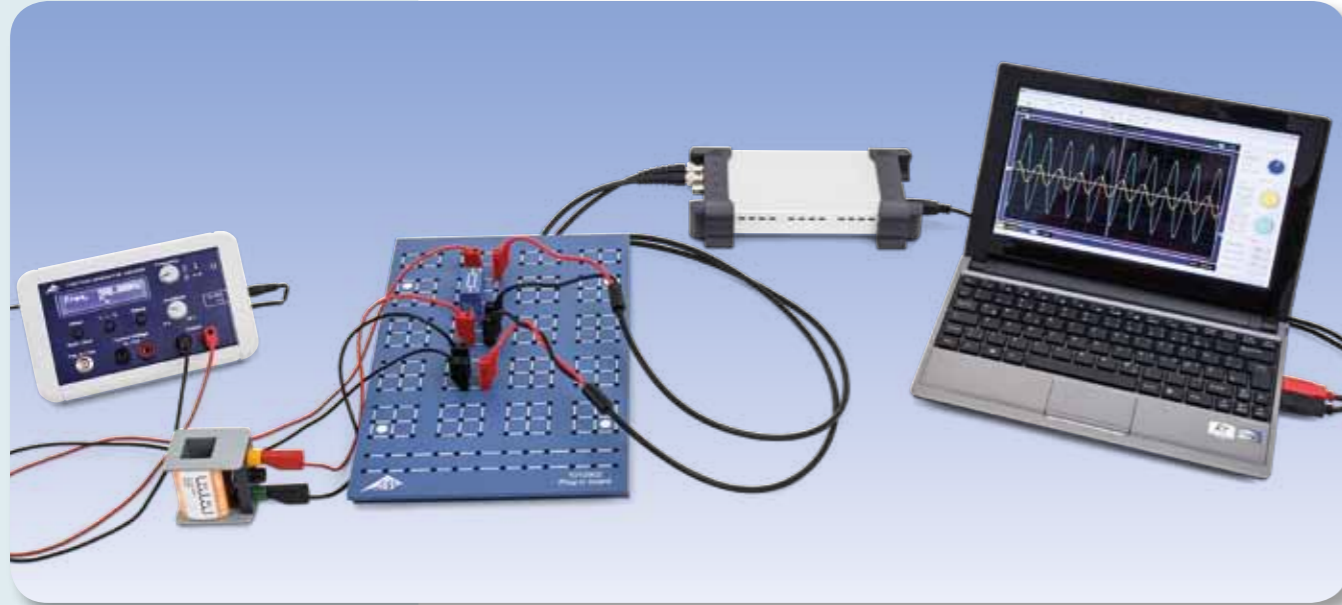

Fig. 4: Half-life $T_{1/2}$ as a function of $\frac{L}{R}$



EXPERIMENT PROCEDURE

- Determine the amplitude and phase of inductive impedance as a function of the inductance.
- Determine the amplitude and phase of inductive impedance as a function of the frequency

OBJECTIVE

Determine inductive impedance as a function of inductance and frequency

SUMMARY

Any change in the current through a coil induces a voltage. If an alternating current flows, an AC voltage will be induced, which is shifted in phase with respect to the current. In mathematical terms, the relationship can be expressed most easily if current, voltage and impedance are regarded as complex values, whereby the real components need to be considered. In this experiment, a frequency generator supplies an alternating voltage with a frequency of up to 2 kHz. A dual-channel oscilloscope is used to record the voltage and current, so that the amplitude and phase of both can be determined. The current through the coil is given by the voltage drop across a resistor with a value which is negligible in comparison to the inductive impedance exhibited by the coil itself.

REQUIRED APPARATUS

Quantity	Description	Number
1	Plug-In Board for Components	1012902
2	Coil S with 1200 Taps	1001002
1	Resistor 10 Ω, 2 W, P2W19	1012904
1	Function Generator FG 100 (230 V, 50/60 Hz)	1009957 or
	Function Generator FG 100 (115 V, 50/60 Hz)	1009956
1	USB Oscilloscope 2x50 MHz	1017264
2	HF Patch Cord, BNC/4 mm Plug	1002748
1	Set of 15 Experiment Leads, 75 cm 1 mm ²	1002840

2

BASIC PRINCIPLES

Any change in the current through a coil induces a voltage which acts such as to oppose the change in current. If an alternating current flows, an AC voltage will be induced, which is shifted in phase with respect to the current. In mathematical terms, the relationship can be expressed most easily if current, voltage and impedance are regarded as complex values, whereby the real components need to be considered.

The relationship between current and voltage for a coil is as follows:

$$(1) \quad U = L \cdot \frac{dI}{dt}$$

I : Current, U : Voltage, L : Inductance

Assume the following voltage is applied:

$$(2) \quad U = U_0 \cdot \exp(i \cdot 2\pi \cdot f \cdot t)$$

This gives rise to a current as follows:

$$(3) \quad I = \frac{U_0}{i \cdot 2\pi \cdot f \cdot L} \cdot \exp(i \cdot 2\pi \cdot f \cdot t)$$

The impedance associated with the inductor L can then be defined as in the following equation:

$$(4) \quad X_L = \frac{U}{I} = i \cdot 2\pi \cdot f \cdot L$$

The real component of this is measurable, therefore

$$(5a) \quad U = U_0 \cdot \cos \omega t$$

$$(6a) \quad I = \frac{U_0}{2\pi \cdot f \cdot L} \cos\left(\omega t - \frac{\pi}{2}\right) = I_0 \cos\left(\omega t - \frac{\pi}{2}\right)$$

$$(7a) \quad X_L = \frac{U_0}{I_0} = 2\pi \cdot f \cdot L$$

In this experiment, a frequency generator supplies an alternating voltage with a frequency of up to 2 kHz. A dual-channel oscilloscope is used to record the voltage and current, so that the amplitude and phase of both can be determined. The current through the capacitor is related to the voltage drop across a resistor with a value which is negligible in comparison to the inductive impedance exhibited by the coil itself.



Fig. 1: Coil in an AC circuit: Current and voltage over time

EVALUATION

As per equation (4), the inductive impedance X_L is proportional to the frequency f and the inductance L . In the relevant graphs, the measurements therefore lie along a straight line through the origin within the measurement tolerances.

The phase of the current through the coil is 90° behind that of the voltage, since every change in current induces an opposing voltage.

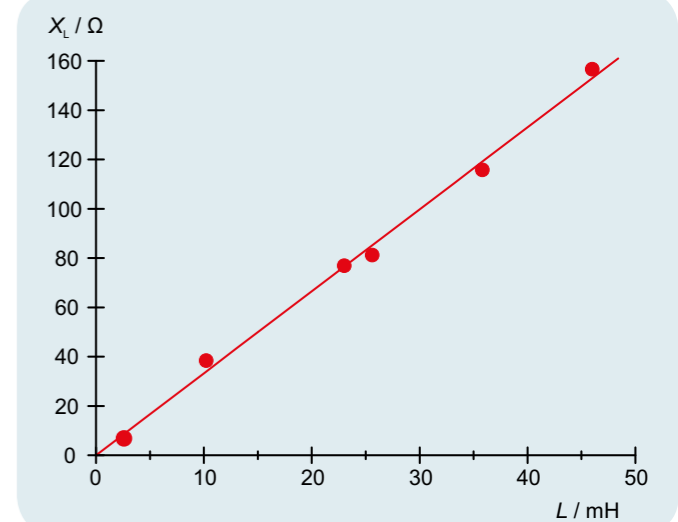

Fig. 2: Inductive impedance X_L as a function of inductance L

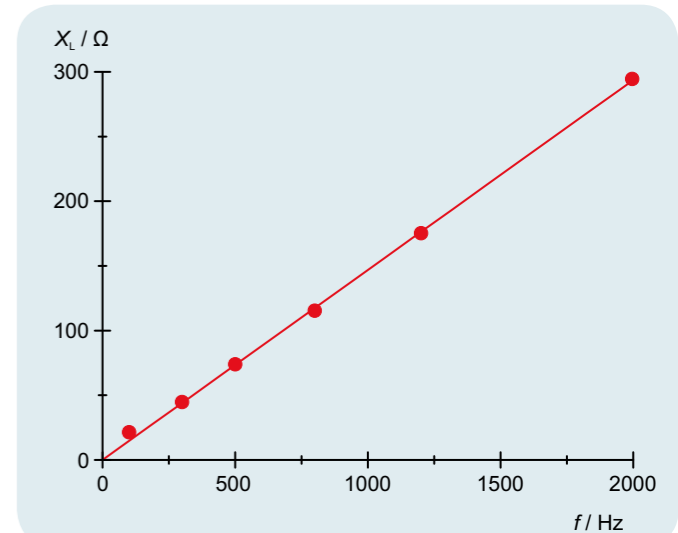
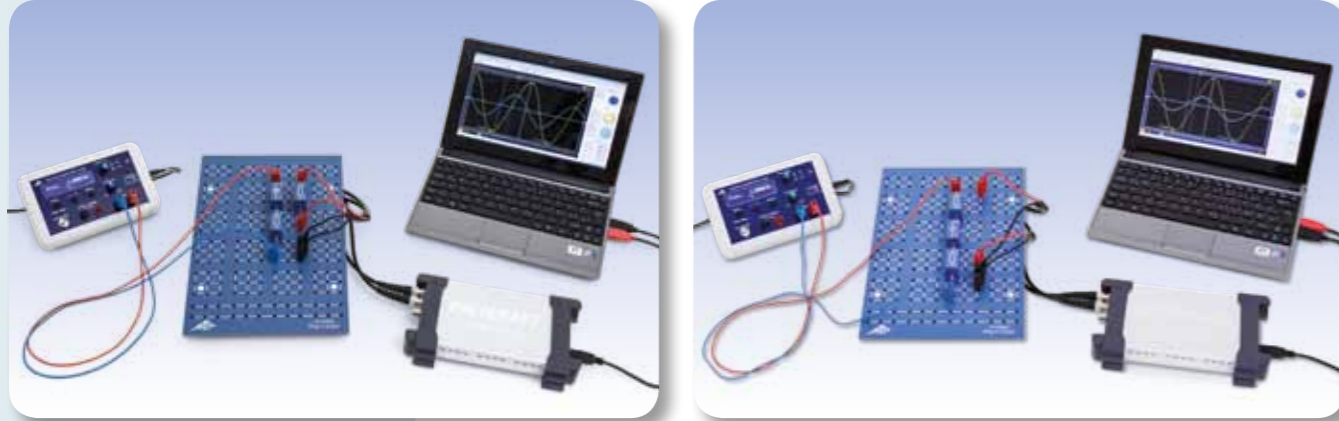

Fig. 3: Inductive impedance X_L as a function of frequency f



EXPERIMENT PROCEDURE

- Determine the amplitude and phase of the overall resistance as a function of frequency for a series circuit.
- Determine the amplitude and phase of the overall resistance as a function of frequency for a parallel circuit.

OBJECTIVE

Determine the AC resistance in a circuit with capacitive and resistive loads

SUMMARY

In AC circuits, not only ohmic resistance needs to be taken into account but also the resistance due to capacitive loads. The combination of the two may be connected in series or parallel. This has an effect on both the amplitudes and phase of the current and voltage. In the experiment, this will be investigated using an oscilloscope and a function generator supplying alternating current with frequencies between 50 and 2000 Hz.

REQUIRED APPARATUS

Quantity	Description	Number
1	Plug-In Board for Components	1012902
1	Resistor 1 Ω, 2 W, P2W19	1012903
1	Resistor 100 Ω, 2 W, P2W19	1012910
1	Capacitor 10 μF, 35 V, P2W19	1012957
1	Capacitor 1 μF, 100 V, P2W19	1012955
1	Capacitor 0.1 μF, 100 V, P2W19	1012953
1	Function Generator FG 100 (230 V, 50/60 Hz)	1009957 or
1	Function Generator FG 100 (115 V, 50/60 Hz)	1009956
1	USB Oscilloscope 2x50 MHz	1017264
2	HF Patch Cord, BNC/4 mm Plug	1002748
1	Set of 15 Experiment Leads, 75 cm 1 mm ²	1002840

BASIC PRINCIPLES

In AC circuits, it is common to use complex numbers to describe the resistance in circuits with capacitors because this actually makes calculation easier. This is because not only the amplitude of the current and voltage is a factor, but also the phase relationships between the two need to be taken into account (this complex resistance is usually called impedance). Series and parallel circuits with both ohmic and capacitive resistance can then be described quite easily, although in each case, only the real component is measurable).

2

The complex resistance (impedance) of a capacitor with capacitance C in a circuit with an alternating current of frequency f is as follows:

$$(1) \quad X_c = \frac{1}{i \cdot \omega \cdot C}$$

$$\text{Angular frequency} \quad \omega = 2\pi \cdot f$$

Therefore series circuits containing a capacitor and an ohmic resistor R will have the following overall resistance:

$$(2) \quad Z_s = \frac{1}{i \cdot \omega \cdot C} + R,$$

A parallel circuit can be assigned the following overall resistance

$$(3) \quad Z_p = \frac{1}{i \cdot \omega \cdot C + \frac{1}{R}}$$

The usual way of expressing this is as follows:

$$(4) \quad Z = Z_0 \cdot \exp(i \cdot \varphi)$$

This becomes

$$(5) \quad Z_s = \frac{\sqrt{1 + (\omega \cdot C \cdot R)^2}}{\omega \cdot C} \cdot \exp(i \cdot \varphi_s)$$

where and

$$\tan \varphi_s = -\frac{1}{\omega \cdot C \cdot R}$$

$$(6) \quad Z_p = \frac{R}{\sqrt{1 + (\omega \cdot C \cdot R)^2}} \cdot \exp(i \cdot \varphi_p)$$

where

$$\tan \varphi_p = -\omega \cdot C \cdot R.$$

In this experiment a function generator supplies an AC voltage with a frequency f , which is adjusted between 50 and 2000 Hz. Voltage U and current I are recorded on an oscilloscope, whereby, I is displayed in the form of the voltage drop across a small auxiliary resistor. This allows the real components of the voltage across the relevant resistance Z .

$$(7) \quad U = U_0 \cdot \exp(i \cdot \omega \cdot t)$$

The resulting current is as follows:

$$(8) \quad I = \frac{U_0}{Z_0} \cdot \exp(i \cdot (\omega \cdot t - \varphi)) \\ = I_0 \cdot \exp(i \cdot (\omega \cdot t - \varphi))$$

The amplitudes I_0 and U_0 , plus the phase shift φ can all be read from the oscilloscope.

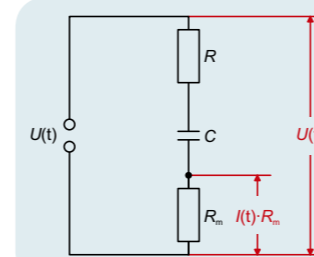

Fig. 1: Measurement set-up for series circuit

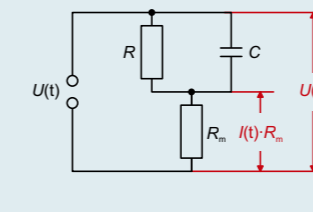

Fig. 2: Measurement set-up for parallel circuit

EVALUATION

The magnitude of the overall resistance (impedance) $Z_0 = \frac{U_0}{I_0}$ is displayed as a function of frequency f or of the capacitive resistance $X_c = \frac{1}{2\pi \cdot f \cdot C}$. At low frequencies the resistance of the series circuit corresponds to the capacitive resistance and that of the parallel circuit corresponds to the ohmic resistance. The phase shift is between 0° and 90° and equals 45° if the ohmic and capacitive resistance values are the same.

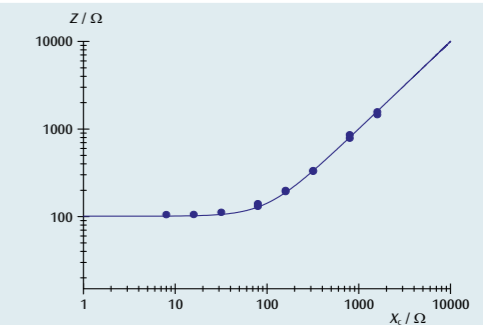

Fig. 3: Overall resistance for series circuit

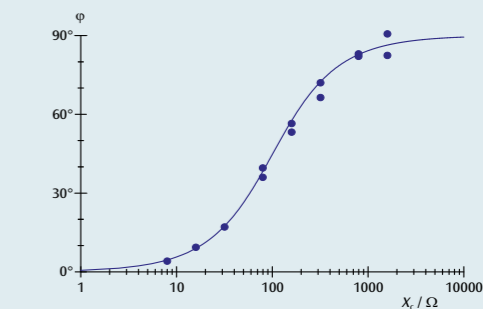

Fig. 4: Phase shift for series circuit

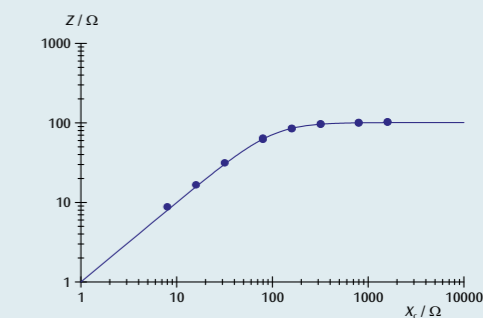

Fig. 5: Overall resistance for parallel circuit

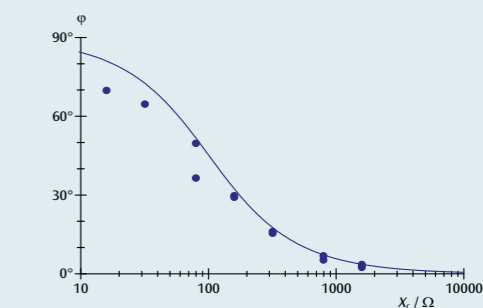
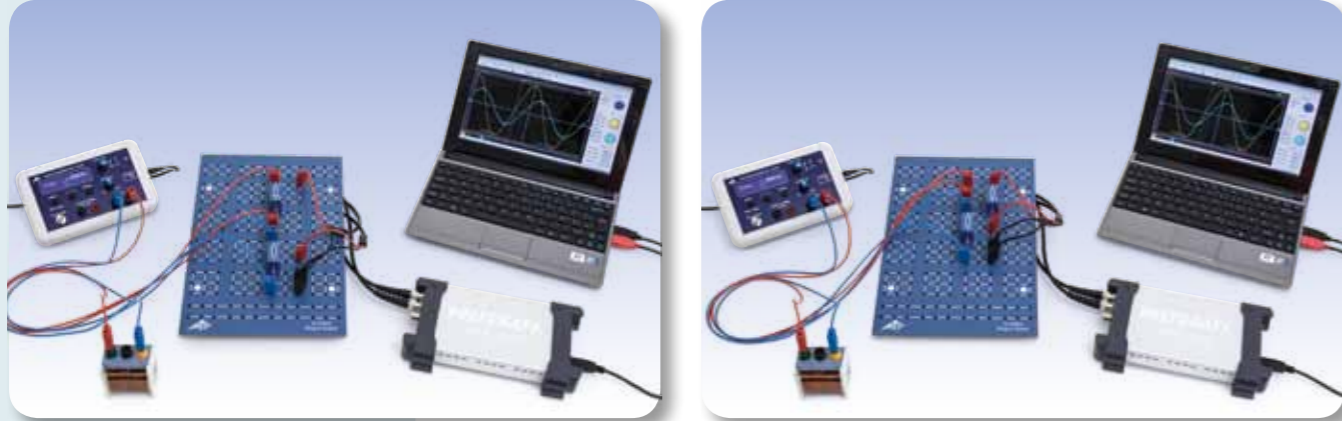

Fig. 6: Phase shift for parallel circuit



EXPERIMENT PROCEDURE

- Determine the amplitude and phase of the overall resistance as a function of frequency for a series circuit.
- Determine the amplitude and phase of the overall resistance as a function of frequency for a parallel circuit.

OBJECTIVE

Determine the AC resistance in a circuit with inductive and resistive loads

SUMMARY

In AC circuits, not only ohmic resistance needs to be taken into account but also the resistance due to inductive loads. The combination of the two may be connected in series or parallel. This has an effect on both the amplitudes and phase of the current and voltage. In the experiment, this will be investigated using an oscilloscope and a function generator supplying alternating current with frequencies between 50 and 10000 Hz.

REQUIRED APPARATUS

Quantity	Description	Number
1	Plug-In Board for Components	1012902
1	Resistor 1 Ω, 2 W, P2W19	1012903
1	Resistor 100 Ω, 2 W, P2W19	1012910
1	Function Generator FG 100 (230 V, 50/60 Hz)	1009957 or
	Function Generator FG 100 (115 V, 50/60 Hz)	1009956
1	USB Oscilloscope 2x50 MHz	1017264
1	HF Patch Cord, BNC/4 mm Plug	1002748
1	Set of 15 Experiment Leads, 75 cm 1 mm ²	1002840
1	Coil S with 600 Taps	1001000
2	Coil S with 1200 Taps	1001002

2

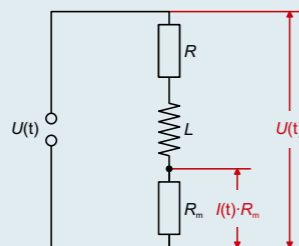

Fig. 1: Measurement set-up for series circuit

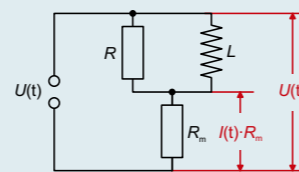

Fig. 2: Measurement set-up for parallel circuit

BASIC PRINCIPLES

In AC circuits, it is common to use complex numbers to describe the resistance in circuits with inductors because this actually makes calculation easier. This is because not only the amplitude of the current and voltage is a factor, but also the phase relationships between the two need to be taken into account (this complex resistance is usually called impedance). Series and parallel circuits with both ohmic and inductive resistance can then be described quite easily, although in each case, only the real component is measurable).

The complex resistance (impedance) of a coil of inductance L in a circuit with an alternating current of frequency f is as follows:

$$(1) \quad X_L = i \cdot 2\pi \cdot f \cdot L$$

$$\text{Angular frequency} \quad \omega = 2\pi \cdot f$$

Therefore the total resistance (impedance) of a series circuit containing a coil with a resistance R is

$$(2) \quad Z_s = i \cdot 2\pi \cdot f \cdot L + R$$

For a parallel circuit, the total resistance can be assigned thus:

$$(3) \quad Z_p = \frac{1}{\frac{1}{i \cdot 2\pi \cdot f \cdot L} + \frac{1}{R}}$$

The usual way of writing this is as follows:

$$(4) \quad Z = Z_0 \cdot \exp(i \cdot \varphi)$$

This becomes

$$(5) \quad Z_s = \sqrt{(2\pi \cdot f \cdot L)^2 + R^2} \cdot \exp(i \cdot \varphi_s)$$

where

$$\tan \varphi_s = \frac{2\pi \cdot f \cdot L}{R}$$

and

$$(6) \quad Z_p = \frac{2\pi \cdot f \cdot L \cdot R}{\sqrt{(2\pi \cdot f \cdot L)^2 + R^2}} \cdot \exp(i \cdot \varphi_p)$$

where

$$\tan \varphi_p = \frac{R}{2\pi \cdot f \cdot L}$$

In this experiment a function generator supplies an AC voltage with an frequency f , which is adjusted between 50 and 10000 Hz. Voltage U and current I are recorded on an oscilloscope, whereby, I is displayed in the form of the voltage drop across a small auxiliary resistor. This allows the real components of the voltage across the relevant resistance Z to be measured.

$$(7) \quad U = U_0 \cdot \exp(i \cdot 2\pi \cdot f \cdot t)$$

The resulting current is as follows:

$$(8) \quad I = \frac{U_0}{Z_0} \cdot \exp(i \cdot (2\pi \cdot f \cdot t - \varphi)) \\ = I_0 \cdot \exp(i \cdot (2\pi \cdot f \cdot t - \varphi))$$

The amplitudes I_0 and U_0 , plus the phase shift φ can all be read from the oscilloscope.

EVALUATION

The magnitude of the overall resistance is $Z_0 = \frac{U_0}{I_0}$ displayed as a function of frequency f or of the inductive resistance $X_L = 2\pi \cdot f \cdot L$. If the inductive impedance is large, the resistance of the series circuit will have the value of the inductive resistance and the parallel circuit will have the value of the ohmic resistance. The phase shift is between 0° and 90° and equals 45° if the ohmic and inductive resistance values are the same.

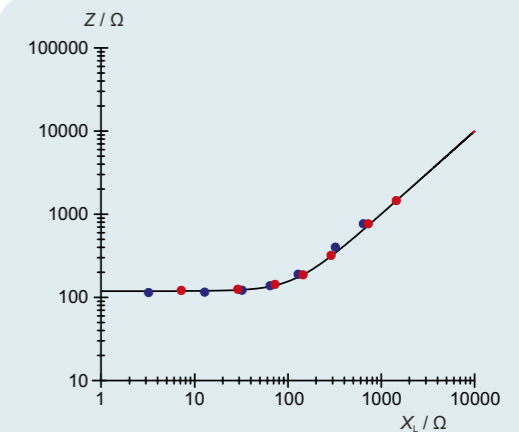

Fig. 3: Overall resistance for series circuit

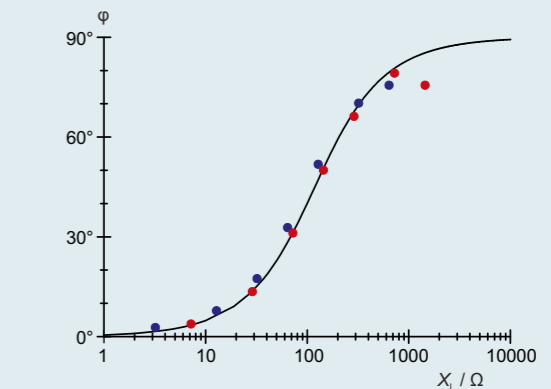

Fig. 4: Phase shift for series circuit

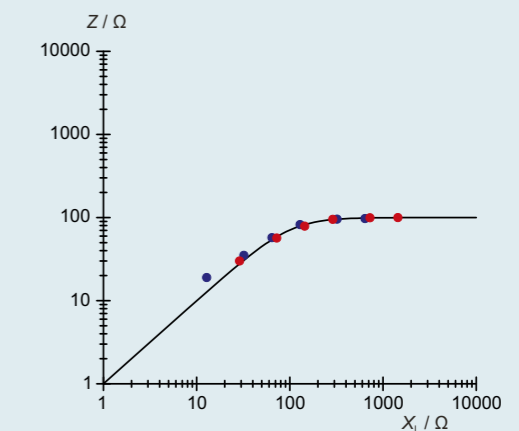

Fig. 5: Overall resistance for parallel circuit

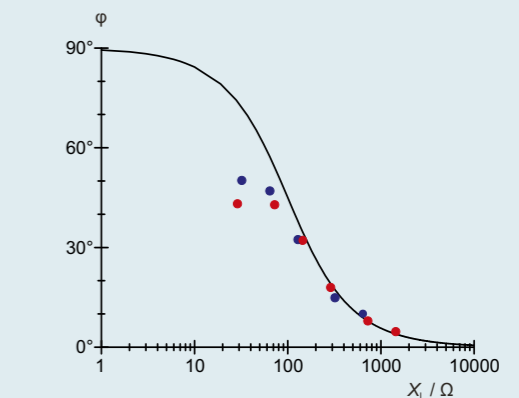
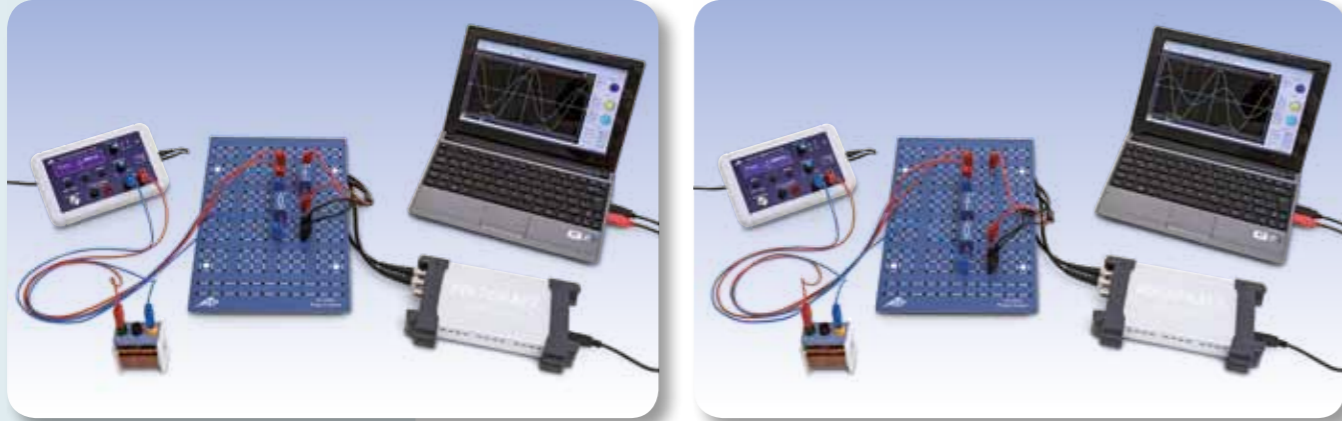

Fig. 6: Phase shift for parallel circuit



EXPERIMENT PROCEDURE

- Determining the impedances of series and parallel connections of capacitive and inductive reactances as a function of frequency.
- Determining resonant frequency as a function of inductance and capacitance.
- Observing changes in phase shift between voltage and current at the resonant frequency.

OBJECTIVE

Determining impedance in a circuit with an inductive and a capacitive reactance

SUMMARY

AC circuits with inductive and capacitive reactances show resonant behaviour. At the resonant frequency, the impedance of a series connection of an inductive and a capacitive reactance is zero, whereas the impedance of a parallel connection is infinite. This experiment examines this phenomenon with the help of an oscilloscope and a function generator which supplies voltages between 50 Hz and 20,000 Hz.

REQUIRED APPARATUS

Quantity	Description	Number
1	Plug-In Board for Components	1012902
1	Capacitor 1 μF , 100 V, P2W19	1012955
1	Capacitor 4.7 μF , 63 V, P2W19	1012946
1	Coil S with 600 Taps	1001000
1	Coil S with 1200 Taps	1001002
1	Resistor 10 Ω , 2 W, P2W19	1012904
1	Function Generator FG 100 (230 V, 50/60 Hz)	1009957 or
	Function Generator FG 100 (115 V, 50/60 Hz)	1009956
1	USB Oscilloscope 2x50 MHz	1017264
2	HF Patch Cord, BNC/4 mm Plug	1002748
1	Set of 15 Experiment Leads, 75 cm 1 mm ²	1002840

BASIC PRINCIPLES

As the frequency of an AC circuit's current rises, the inductive reactance rises too, while the capacitive reactance drops. Series and parallel connections of capacitive and inductive reactances therefore exhibit resonant behaviour. One speaks here of a resonant circuit, its current and voltage oscillating back and forth between the capacitance and inductance. An additional ohmic resistor dampens these oscillations.

2

To simplify calculations for series and parallel connections, inductances L are assigned the following complex reactance:

$$(1) \quad X_L = i \cdot 2\pi \cdot f \cdot L$$

f : Alternating current's frequency

Furthermore, capacitances C are assigned the following complex reactance:

$$(2) \quad X_C = \frac{1}{i \cdot 2\pi \cdot f \cdot C}$$

The total impedance of a series connection without an ohmic resistance therefore is:

$$(3) \quad Z_S = i \cdot \left(2\pi \cdot f \cdot L - \frac{1}{2\pi \cdot f \cdot C} \right),$$

The corresponding calculation for a parallel connection is:

$$(4) \quad \frac{1}{Z_P} = -i \cdot \left(\frac{1}{2 \cdot \pi \cdot f \cdot L} - 2 \cdot \pi \cdot f \cdot C \right)$$

At the resonant frequency

$$(5) \quad f_r = \frac{1}{2 \cdot \pi \cdot \sqrt{L \cdot C}}$$

the impedance Z_S of the series connection comprising inductive and capacitive reactances therefore vanishes, i.e. the voltages across both individual reactances are opposite and equal. By contrast, the value of a parallel connection's impedance Z_P becomes infinite, i.e. the individual currents are opposite and equal. At the resonant frequency, the sign of the phase shift between the voltage and current furthermore changes.

In the experiment, resonant circuits are set up as series / parallel connections of capacitors and inductors. A function generator serves as a voltage source with an adjustable frequency and amplitude. An oscilloscope is used to measure current and voltage as functions of the set frequency. The voltage U and current I are displayed on the oscilloscope; I corresponds to the voltage drop across a small load resistor.

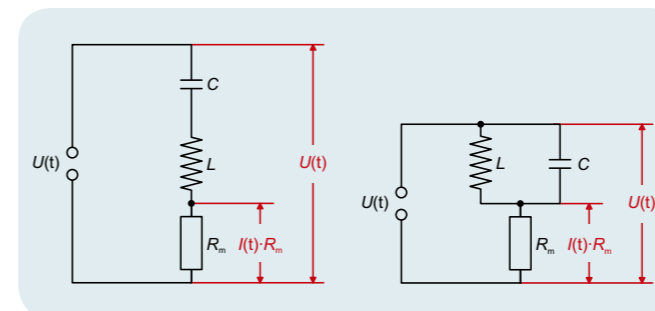

Fig. 1: Measurement setup for a series connection

Fig. 2: Measurement setup for a parallel connection

EVALUATION

For each frequency f , the phase shift ϕ as well as the amplitudes I_0 and U_0 are read on the oscilloscope. The readings are used to calculate the total impedance: $Z_0 = \frac{U_0}{I_0}$.

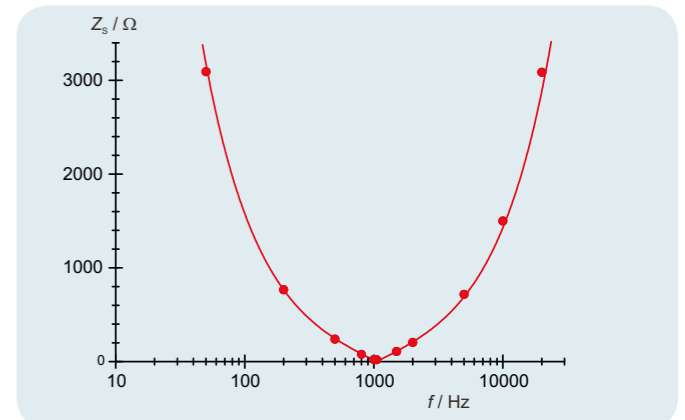

Fig. 3: Impedance of a series connection as a function of frequency

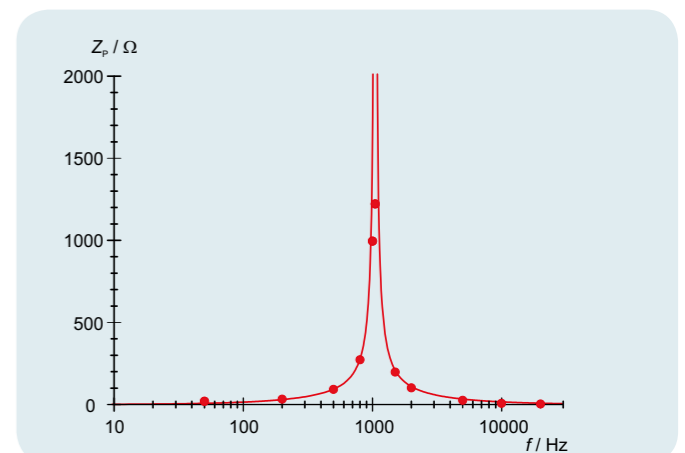

Fig. 4: Impedance of a parallel connection as a function of frequency

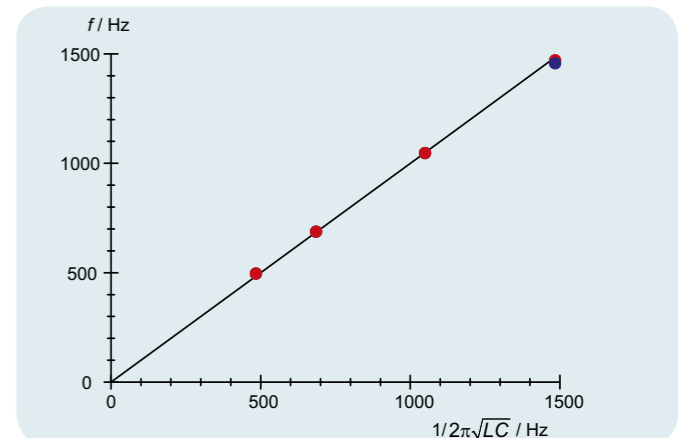
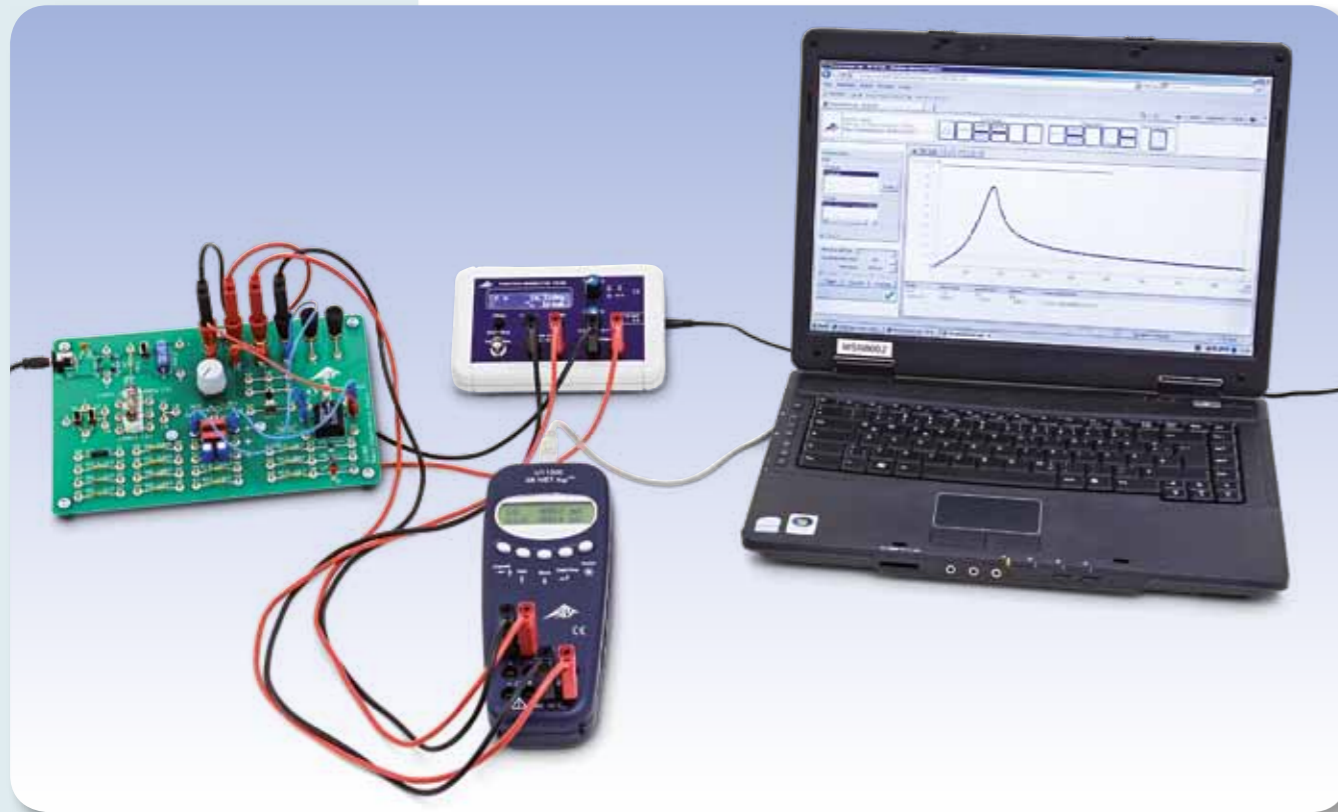

Fig. 5: Comparison between measured and calculated resonant frequencies for a series connection (red) and a parallel connection (blue)



EXPERIMENT PROCEDURE

- Record an amplitude resonance curve for a series LC resonant circuit with various degrees of damping.
- Determine the resonant frequency of the series LC resonant circuit.

OBJECTIVE

Investigate the resonance response of a series LC resonant circuit

SUMMARY

An electric resonant (also resonance or tuned) circuit is a circuit which is capable of resonating at a specific frequency. It comprises an inductor and a capacitor. In this experiment an AC voltage is generated with the help of a function generator and fed to a series resonant circuit. What will be measured is the amplitude resonance curve, i.e. the current as a function of the frequency at a constant voltage amplitude. If the capacitance is known, it is possible to calculate the unknown inductance of the circuit.

REQUIRED APPARATUS

Quantity	Description	Number
1	Basic Experiment Board (230 V, 50/60 Hz)	1000573 or
	Basic Experiment Board (115 V, 50/60 Hz)	1000572
1	3B NETlog™ (230 V, 50/60 Hz)	1000540 or
	3B NETlog™ (115 V, 50/60 Hz)	1000539
1	3B NETlab™	1000544
1	Function Generator FG 100 (230 V, 50/60 Hz)	1009957 or
	Function Generator FG 100 (115 V, 50/60 Hz)	1009956
1	Set of 15 Experiment Leads, 75 cm 1 mm²	1002840

2

BASIC PRINCIPLES

An electric resonant circuit is a circuit consisting of an inductor with inductance L and a capacitor with capacitance C . The periodic transfer of energy between the magnetic field of the coil and the electric field of the capacitor results in oscillation of the electric circuit. This transfer results in alternating instances where there is maximum current through the coil or maximum voltage across the capacitor.

If the resonant circuit is not oscillating freely, but is excited by an external sine-wave signal, it oscillates at the same frequency as the excitation signal and the amplitude of the current and voltage across the individual components are dependent on the frequency. The current I can be deduced from Ohm's law as follows:

$$(1) \quad I = \frac{U}{Z} = \frac{U_0 \cdot e^{i\omega t}}{Z}$$

U : sinusoidal input voltage

U_0 : amplitude, ω : angular frequency

Z : total impedance

In a series circuit, the total impedance is made up of the sum of the impedances of the individual components. In addition there is an ohmic resistance R , which covers the losses which inevitably occur in a real resonant circuit and which may also have any external resistance added to it. The following expression therefore arises:

$$(2) \quad Z = R + i\omega L + \frac{1}{i\omega C}$$

From equation (1) and (2) the current is given by

$$(3) \quad I(\omega) = \frac{U_0 \cdot e^{i\omega t}}{R + i\left(\omega L - \frac{1}{\omega C}\right)}$$

The magnitude of the current corresponds to its amplitude, which is frequency-dependent:

$$(4) \quad I_0(\omega) = \frac{U_0}{\sqrt{R^2 + \left(\omega L - \frac{1}{\omega C}\right)^2}}$$

This reaches its maximum value at the resonant frequency

$$(5) \quad f_r = \frac{\omega_r}{2\pi} = \frac{1}{2\pi \cdot \sqrt{L \cdot C}}$$

At that point, its magnitude is

$$(6) \quad I_0(\omega_r) = \frac{U_0}{R}$$

Therefore, in the case of resonance, the resonant circuit behaves as if it consisted solely of an ohmic resistance. In particular, an inductor and capacitor connected in series act as if they were a short circuit when resonance is occurring.

This experiment involves an AC voltage generated by a function generator being used to excite the tuned circuit. The current I is measured as a function of the frequency f while the amplitude of the voltage remains constant. The current is measured using a measuring interface and recorded by means of measurement and evaluation software which allows it to be displayed graphically. The amplitude resonance curve of the current, i.e. the way the amplitude of the current depends on the frequency, is recorded automatically.

EVALUATION

The resonant frequency f_r can be read off from the amplitude resonance curve. Since the capacitance C is known, it is possible to calculate the size of the inductor being used by means of equation (5):

$$L = \frac{1}{4\pi^2 \cdot f_r^2 \cdot C}$$

Using equation (6), the ohmic resistance R can be calculated from the amplitude of the resonance curve. If no external resistor is connected, R represents the ohmic losses inherent in a real resonant circuit.

$$R = \frac{U_0}{I_0(\omega_r)}$$

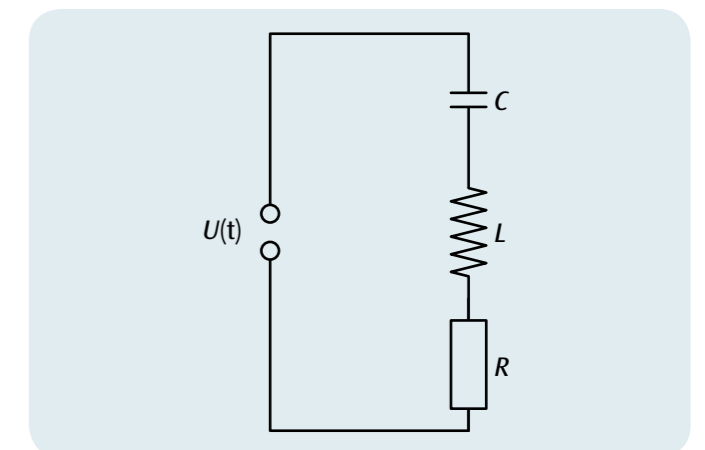

Fig. 1: Circuit diagram sketch for series LC resonant circuit

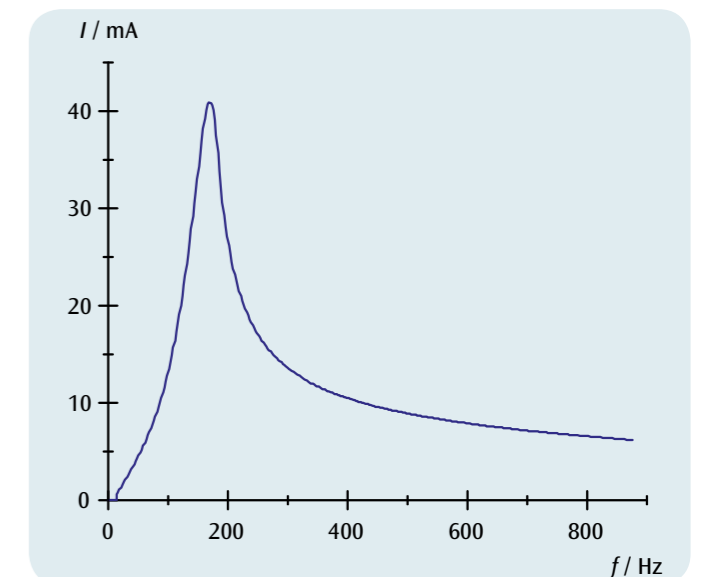
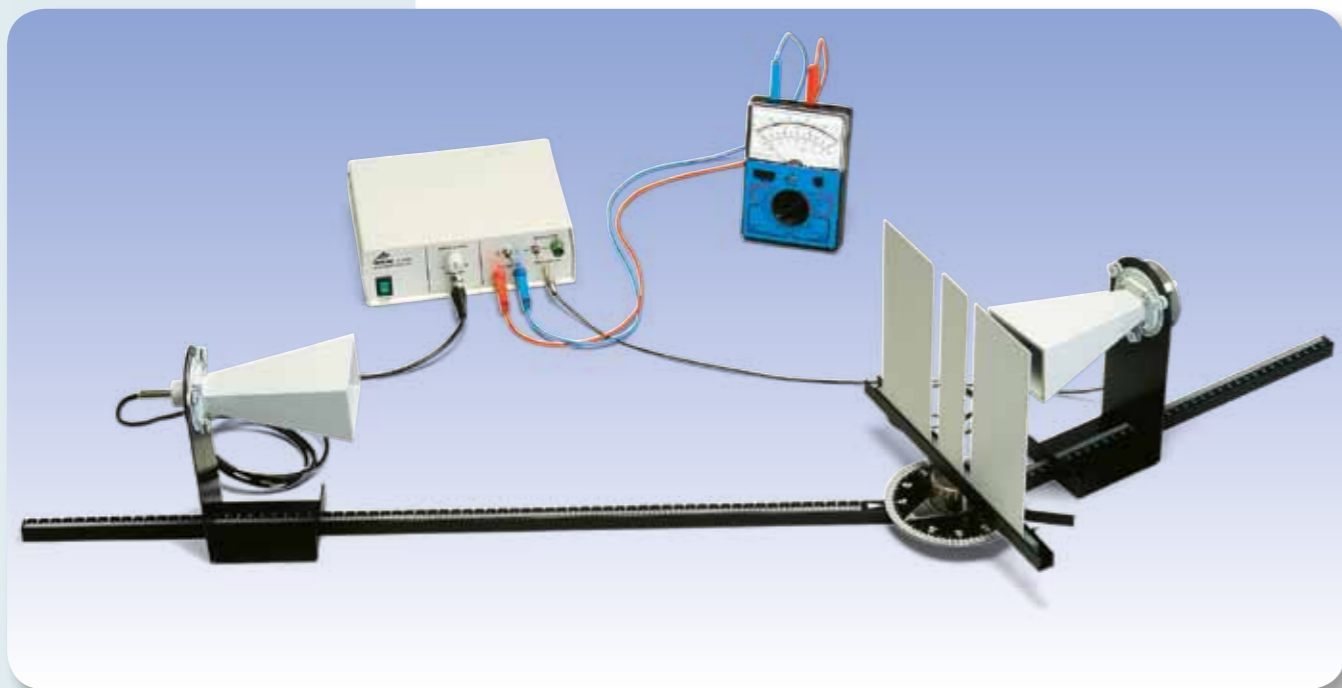

Fig. 2: Amplitude resonance curve of the current ($R_{\text{ext}} = 0$)



EXPERIMENT PROCEDURE

- Take point-by-point measurements of the intensity when microwaves are diffracted at a pair of slits.
- Determine the positions of the maxima for different diffraction orders.
- Determine the wavelength when the distance between the slits is known.
- Investigate the polarisation of the emitted microwaves and modify it.

OBJECTIVE

Demonstrate and investigate the phenomena of interference, diffraction and polarisation using microwaves

SUMMARY

Using microwaves, many experiments can be conducted on interference, diffraction and polarisation, as an aid to understanding these phenomena for visible light. Diffracting objects and polarisation gratings can be used which possess a structure that can be seen with the unaided eye and easily understood. In the case of diffraction by a pair of slits, maximum intensity can be detected at a position where radiation travelling in a straight line from the transmitter could not possibly reach.

REQUIRED APPARATUS

Quantity	Description	Number
1	Microwave Set 9.4 GHz (230 V, 50/60 Hz)	1009951 or
	Microwave Set 10.5 GHz (115 V, 50/60 Hz)	1009950
1	Analogue Multimeter AM50	1003073
1	Pair of Safety Experimental Leads, 75cm, red/blue	1017718

2

BASIC PRINCIPLES

In wave optics light is regarded as consisting of transverse electromagnetic waves. This explains the phenomena of interference, diffraction and polarisation. Microwaves too are electromagnetic waves and they exhibit the same phenomena, but the wavelengths are much greater than those of visible light. Consequently, wave optics experiments can also be carried out using microwaves with diffraction objects and polarisation grids, the internal structure of which is obvious to the unaided eye.

This experiment investigates the diffraction of microwaves of wavelength λ at a pair of slits separated by a distance d of several centimetres. Measure the characteristic intensity distribution for diffraction by a pair of slits (see Fig. 1), with maxima at the angles α_m satisfying the condition:

$$(1) \quad \sin \alpha_m = m \cdot \frac{\lambda}{d}, \quad m = 0, \pm 1, \pm 2, \dots$$

Evidently the maximum intensity is observed when the detector is positioned exactly behind the central strip between the slits ($= 0, m = 0$), where it could not have detected radiation travelling along a straight-line path from the transmitter. This phenomenon can be explained as the result of interference between the partial wave beams from the two slits and is clear evidence for the wave nature of the microwaves.

By rotating the detector about the direction of the source, clear evidence for the linear polarisation of the emitted microwaves can be obtained. When the planes of the transmitter and the detector are crossed at 90° the observed intensity falls to zero. If one of the polarising grids is then placed in the beam at an orientation of 45° to the other, the detector again detects radiation, although with a smaller amplitude than before. The grid transmits that component of the electric field vector of the incoming microwaves that vibrates parallel to the direction of the polarising grid. In this way the component vibrating in the direction parallel to the plane of the detector can be measured.

NOTE

Experiments on the absorption, reflection, refraction and polarisation of microwaves can be performed using the same equipment.

EVALUATION

Measure the diffraction angles α_m for the different intensity maxima and plots a graph of $\sin \alpha_m$ against the diffraction order m . The experimental measurements lie on a straight line through the origin, the gradient of which corresponds to the ratio λ/d .

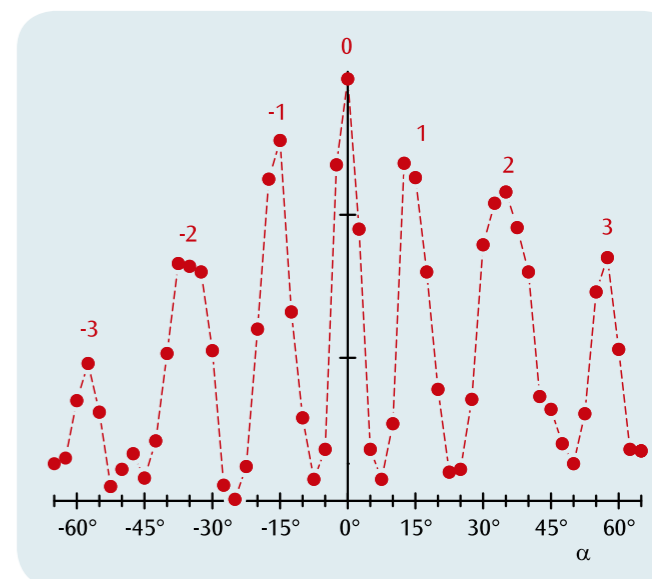

Fig. 1: Intensity distribution resulting from the diffraction of microwaves at a pair of slits

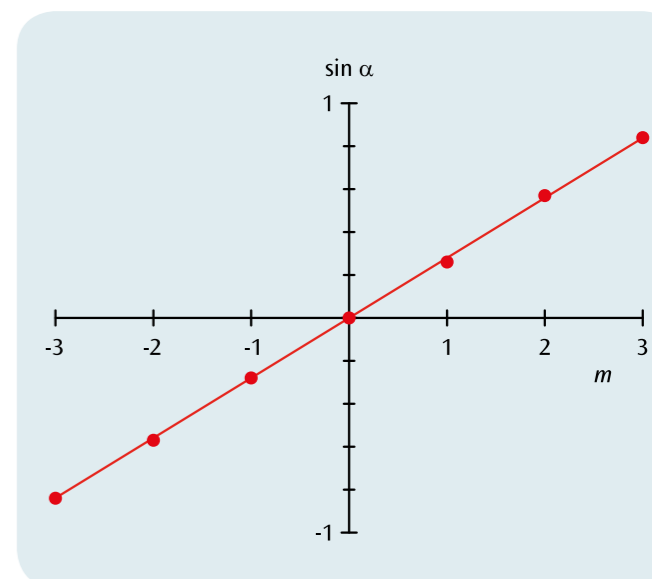

Fig. 2: Positions of the intensity maxima as a function of the diffraction order m



EXPERIMENT PROCEDURE

- Record the characteristic for a thermionic diode at three different cathode heater voltages.
- Identify the space charge and saturation regions.
- Confirm the Schottky-Langmuir law.

OBJECTIVE

Record the characteristic for a thermionic diode

SUMMARY

In a thermionic diode, free electrons carry a flow of current between the heated cathode and the anode when a positive voltage is applied between the cathode and anode. The current increases along with the voltage until a saturation point is reached. However, if the voltage is negative, the current is zero.

REQUIRED APPARATUS

Quantity	Description	Number
1	Diode S	1000613
1	Tube Holder S	1014525
1	DC Power Supply 0 – 500 V (230 V, 50/60 Hz)	1003308 or
	DC Power Supply 0 – 500 V (115 V, 50/60 Hz)	1003307
1	Analogue Multimeter AM50	1003073
1	Set of 15 Safety Experiment Leads, 75 cm	1002843

1

BASIC PRINCIPLES

A thermionic diode is an evacuated glass tube that contains two electrodes, a heated cathode that emits electrons due to the thermoelectric effect and an anode (see Fig. 1). A positive voltage between cathode and anode causes a current flow due to the transport of these emitted electrons from the cathode to the anode. If the voltage is low, the anode current is prevented from flowing since the charge of the emitted electrodes around the cathode, the space charge, shields the field of the cathode itself. As the anode voltage rises, the field lines penetrate more deeply into the space around the cathode and the anode current increases. It continues to rise until the space around the cathode is fully discharged so that the anode current reaches saturation level. When the voltage is sufficiently negative, however, electrons cannot get to the anode at all so that the anode current is zero in this case.

The way the anode current I_A depends on the anode voltage U_A is called the characteristic of the diode (see Fig. 2). There are three distinct areas, the reverse-bias region (a), the space charge region (b) and the saturation region (c).

In the reverse bias region the anode is at a negative voltage with respect to the cathode. Electrons are then unable to move against the electric field. In the space charge region the anode current depends on the anode voltage in accordance with the Schottky-Langmuir law:

$$(1) \quad I_A \sim U_A^{\frac{3}{2}}$$

In the saturation region the anode current depends on the temperature of the cathode. By increasing the heater voltage U_F the anode current can be made to increase.

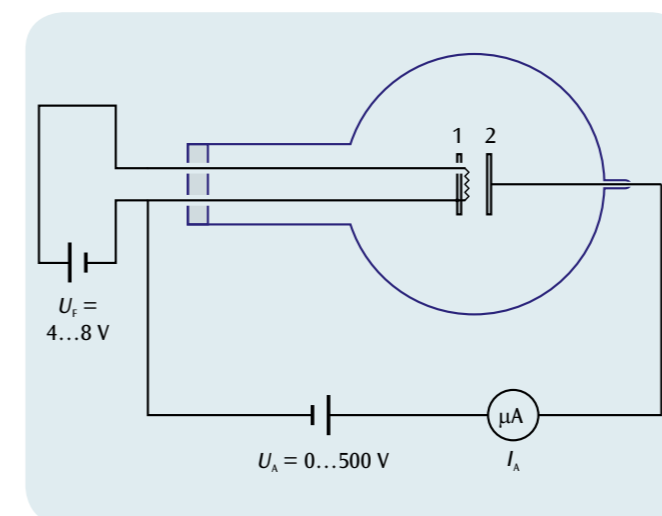

Fig. 1: Circuit for recording the characteristic of a thermionic diode.
1: Cathode, 2: Anode

EVALUATION

Reverse bias region:

Since electrons are emitted from the cathode with a kinetic energy $E_{kin} > 0$ a current flows in the anode only until the voltage of the anode is sufficiently negative that even the fastest of the emitted electrons is unable to overcome the field to reach the anode.

Space charge region:

For weak field strengths, not all the electrons emitted from the cathode are transported to the anode. They occupy the space around the cathode in a cloud creating a negative space charge. When the voltage is low, field lines for the anode thus reach only as far as the electrons in the cloud and not the cathode itself. The latter is thus shielded from the anode field. Only as the voltage increases do the field lines penetrate further into the cathode causing the anode current to rise. The increase continues until the space charge around the cathode is dissipated, at which point the anode current is saturated.

Saturated region:

In the saturation region the anode current does not depend on the anode voltage at all. It can nevertheless be increased by increasing the number of electrons emitted from the cathode in unit time. This can be achieved by raising the temperature of the cathode. The saturation current therefore depends on the heater voltage.

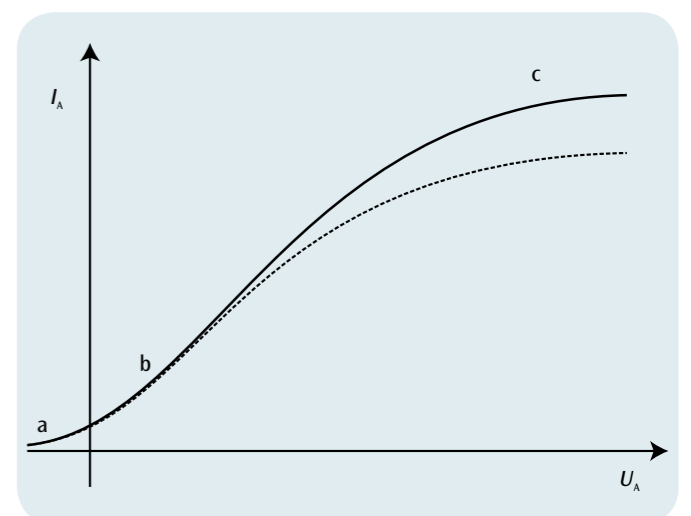

Fig. 2: Characteristic of a thermionic diode
a: Reverse bias region, b: Space charge region, c: Saturation region



EXPERIMENT PROCEDURE

- Record the anode current/anode voltage characteristics for a thermionic triode at various constant grid voltages.
- Record the anode current/grid voltage characteristics for a thermionic triode at various constant anode voltages.

OBJECTIVE

Record characteristics for a thermionic triode

SUMMARY

In a thermionic triode, free electrons carry a flow of current between the heated cathode and the anode when a positive voltage is applied between the cathode and anode. This current can be controlled by applying a positive or negative voltage to an intervening grid.

REQUIRED APPARATUS

Quantity	Description	Number
1	Triode S	1000614
1	Tube Holder S	1014525
1	DC Power Supply 0 – 500 V (230 V, 50/60 Hz)	1003308 or
	DC Power Supply 0 – 500 V (115 V, 50/60 Hz)	1003307
1	Analogue Multimeter AM50	1003073
1	Set of 15 Safety Experiment Leads, 75 cm	1002843

1

BASIC PRINCIPLES

A thermionic triode is an evacuated glass tube that contains three electrodes, a heated cathode that emits electrons due to the thermo-electric effect and an anode with a grid placed in between them. At sufficiently high positive voltage between the cathode and anode (anode voltage), free electrons from the cathode can pass through the grid to reach the anode. The anode current generated in this way can be modulated by varying another voltage between the cathode and the grid. Depending on whether the grid is at positive or negative potential to the cathode, the anode current is either amplified or weakened. A thermionic triode can thus be used for amplifying AC voltages.

This experiment involves recording the set of characteristics for a thermionic triode. These incorporate the way the anode current I_A depends on the anode voltage U_A and on the grid voltage U_G . There are two common ways of portraying these characteristics (see Figs. 2 and 3): Fig. 2 shows the anode current as a function of the anode voltage at various constant grid voltages and Fig. 3 shows the anode current as a function of the grid voltage at various different constant anode voltages.

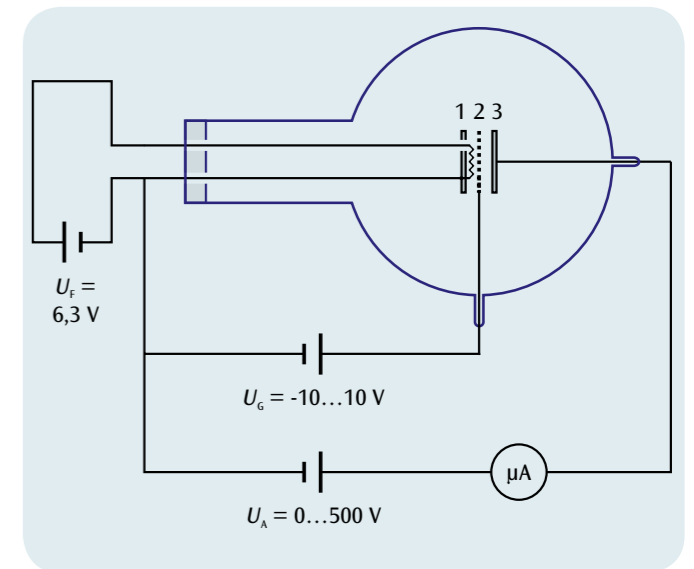

Fig. 1: Circuit for recording the characteristics of a thermionic triode
1: Cathode, 2: Grid, 3: Anode

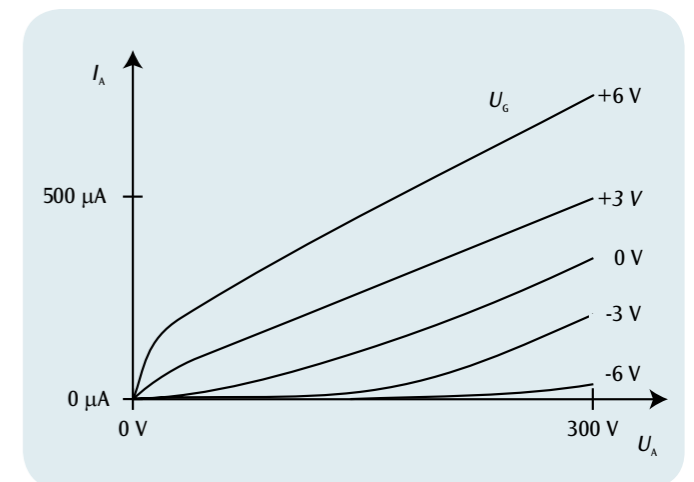

Fig. 2: Anode current/anode voltage characteristics

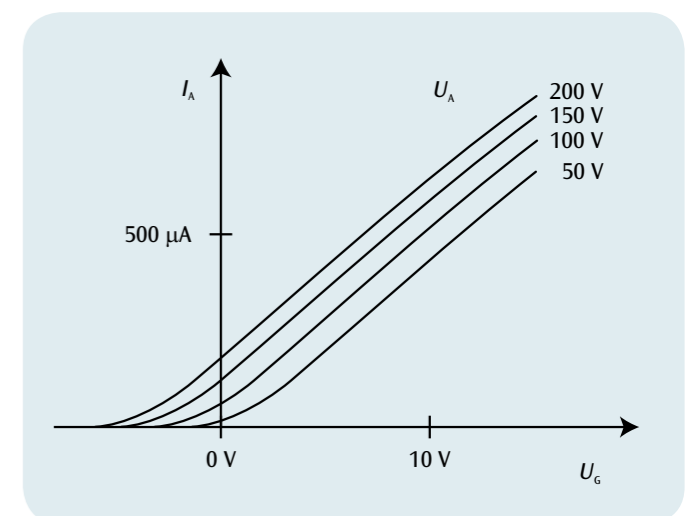
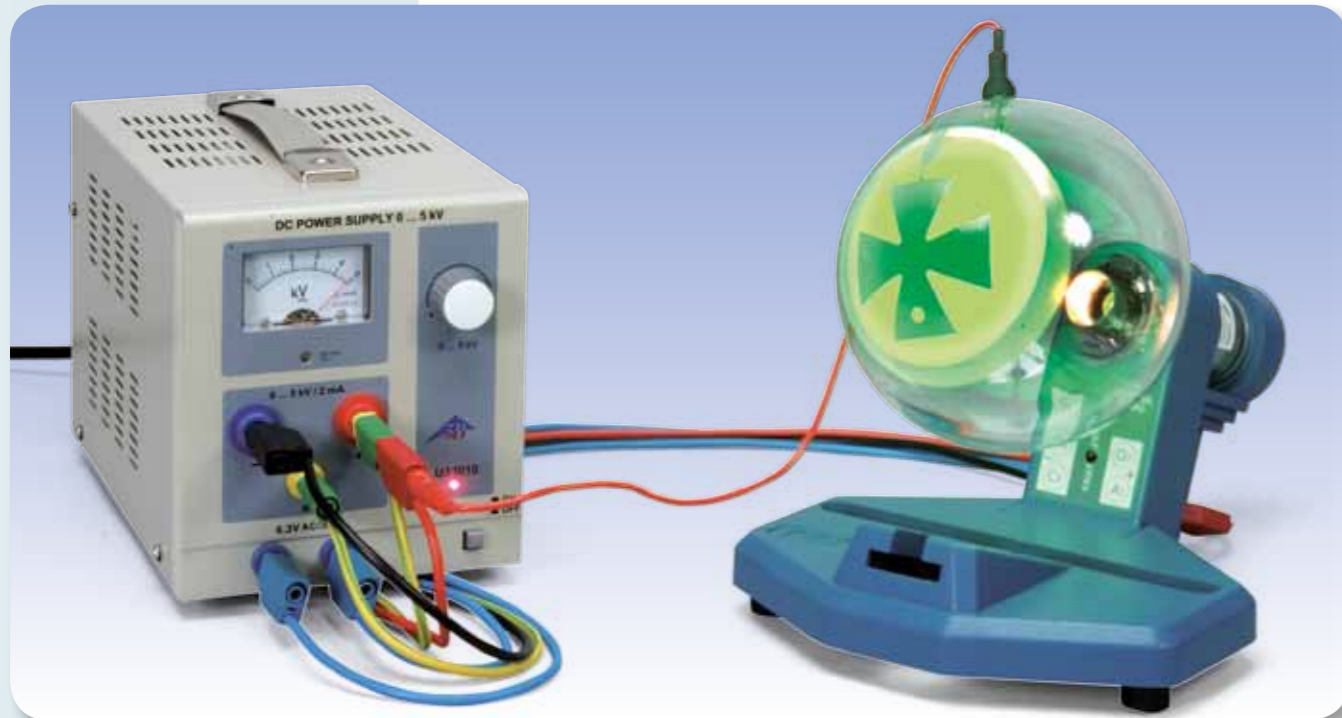

Fig. 3: Anode current/grid voltage characteristics

EVALUATION

The anode current rises as the anode voltage or the grid voltage rises. Even slight changes in the grid voltage of the order of a few volts can lead to large variations in the anode current. The grid voltage can thus be used to control the anode current.



EXPERIMENT PROCEDURE

- Demonstrate the straight-line propagation of electrons in the absence of a field.
- Demonstrate the deflection of electrons by a magnetic field.
- Introduction to electron optics.

OBJECTIVE

Demonstrate the straight-line propagation of electrons in the absence of any field

SUMMARY

Straight-line propagation of electrons in the absence of a field can be demonstrated in a Maltese-cross tube by showing how the shadow of the electron beam coincides with the shadow due to a light beam. Any deviation from the straight-line propagation of the beam, due to a magnetic field for example, can be seen since the shadow is then caused to move.

REQUIRED APPARATUS

Quantity	Description	Number
1	Maltese Cross Tube S	1000011
1	Tube Holder S	1014525
1	High Voltage Power Supply 5 kV (230 V, 50/60 Hz)	1003310 or
	High Voltage Power Supply 5 kV (115 V, 50/60 Hz)	1003309
1	Set of 15 Safety Experiment Leads, 75 cm	1002843
Additionally recommended for generating an axially aligned magnetic field:		
Quantity	Description	Number
1	Helmholtz Pair of Coils S	1000611
1	DC Power Supply 0 – 20 V, 0 – 5 A (230 V, 50/60 Hz)	1003312 or
	DC Power Supply 0 – 20 V, 0 – 5 A (115 V, 50/60 Hz)	1003311

1

BASIC PRINCIPLES

In a Maltese-cross tube, a divergent electron beam from a cathode ray gun can be seen on a fluorescent screen by observing the shadow on the screen of an object (a Maltese cross) that is opaque to cathode rays. The position of the shadow changes when the straight-line propagation of the electrons towards the screen is disturbed.

If the anode and the Maltese-cross are at the same potential, there will be no field within the tube and electrons will propagate in a straight line. The electron shadow of the cross will then be coincident with its shadow in the light that is emitted from the glowing cathode.

How this straight-line propagation is disturbed when a field is present within the tube can be easily seen by disconnecting the lead between the anode and the cross. The cross then becomes statically charged and the electron shadow on the screen becomes blurred.

If the electrons are deflected by a magnetic field on their way to the screen, the electron shadow can be seen to shift or rotate.

The deflecting force F depends on the velocity v of the electrons, on the magnetic field B and is a result of the Lorentz-force:

$$(1) \quad F = -e \cdot v \times B$$

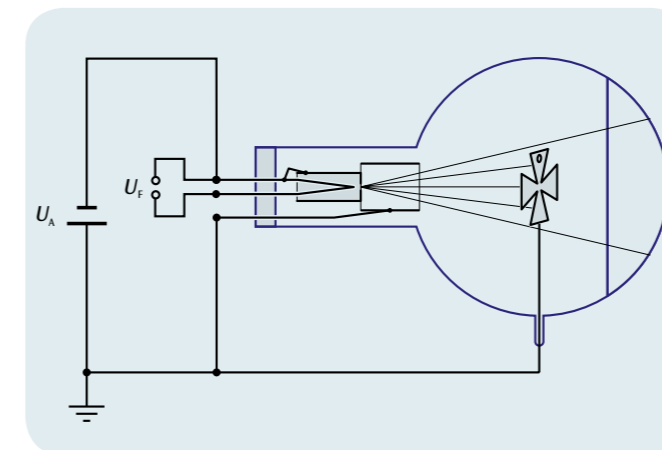

Fig. 1: Schematic of Maltese cross tube

EVALUATION

In the absence of a field the electrons propagate in a straight line. The electron shadow exactly matches the shadow from the light.

In a magnetic field electrons are deflected and the electron shadow is shifted with respect to the shadow from the light. The deflecting force is perpendicular to the direction of motion of the electrons and to the magnetic field itself.

If the magnetic field is aligned axially, the electrons are deflected into spiral paths and the shadow rotates and becomes smaller.



Fig. 2: Rotation of the electron shadow through deflection of electrons in the axially aligned magnetic field



EXPERIMENT PROCEDURE

- Observing the thermionic emission of charge-carriers from a heated cathode.
- Determining the polarity of the emitted charge-carriers.
- Estimating the specific charge (charge-to-mass ratio) of the charge-carriers.

OBJECTIVE

Determine the polarity of the charge-carriers

SUMMARY

In the Perrin tube, the electron beam can be deflected into a Faraday cup by applying a homogeneous magnetic field. The charge of the electrons can be observed by connecting an electroscope to the Faraday cup, and its polarity can be determined by comparison with an electric charge of known polarity.

REQUIRED APPARATUS

Quantity	Description	Number
1	Perrin Tube S	1000616
1	Tube Holder S	1014525
1	Helmholtz Pair of Coils S	1000611
1	High Voltage Power Supply 5 kV (230 V, 50/60 Hz)	1003310 or
	High Voltage Power Supply 5 kV (115 V, 50/60 Hz)	1003309
1	DC Power Supply 0 – 20 V, 0 – 5 A (230 V, 50/60 Hz)	1003312 or
	DC Power Supply 0 – 20 V, 0 – 5 A (115 V, 50/60 Hz)	1003311
1	Kolbe's Electroscope	1001027
1	Set of 15 Safety Experiment Leads, 75 cm	1002843

1

BASIC PRINCIPLES

In the Perrin tube, a focused electron beam falls onto a fluorescent screen, where it is observed as a bright dot. A Faraday cup is placed at 45° to the electron beam, and the electrons can then be deflected into it by applying a magnetic field. The flow of charge can be measured through a separate electrical connection.

In the experiment, the electron beam is deflected by the homogeneous magnetic field of a Helmholtz coil pair into the Faraday cup, which is connected to an electroscope. From the observed charging or discharging of the electroscope by the electron beam entering the Faraday cup, it is possible to determine the polarity of the charge-carriers.

It is also possible to estimate the specific charge of the charge-carriers, since the radius of curvature r of the curved path into the Faraday cup is known. The centripetal force acting on the charge-carriers in this curved path is given by the Lorentz force as follows:

$$(1) \quad m \cdot \frac{v^2}{r} = e \cdot v \cdot B$$

e : Carrier charge, m : Mass of the charge-carrier,
 B : Magnetic flux density.

Also, the velocity v of the charge-carriers depends on the anode voltage U_A as follows:

$$(2) \quad v = \sqrt{2 \cdot \frac{e}{m} \cdot U_A}$$

Combining Equations 1 and 2 gives the following expression for the specific charge (charge-to-mass ratio) of the charge-carriers:

$$(3) \quad \frac{e}{m} = \frac{2 \cdot U_A}{(B \cdot r)^2}$$

EVALUATION

The radius of curvature r of the curved path to the Faraday cup is 160 mm. The anode voltage U_A is known.

The magnetic field B is generated by a Helmholtz coil pair and is proportional to the current I_H through each of the coils. The proportionality factor k can be calculated from the coil radius $R = 68$ mm and the number of turns on each coil, which is $N = 320$.

Thus:

$$B = k \cdot I_H \quad \text{with} \quad k = \left(\frac{4}{5}\right)^{\frac{3}{2}} \cdot 4\pi \cdot 10^{-7} \frac{\text{Vs}}{\text{Am}} \cdot \frac{N}{R}$$

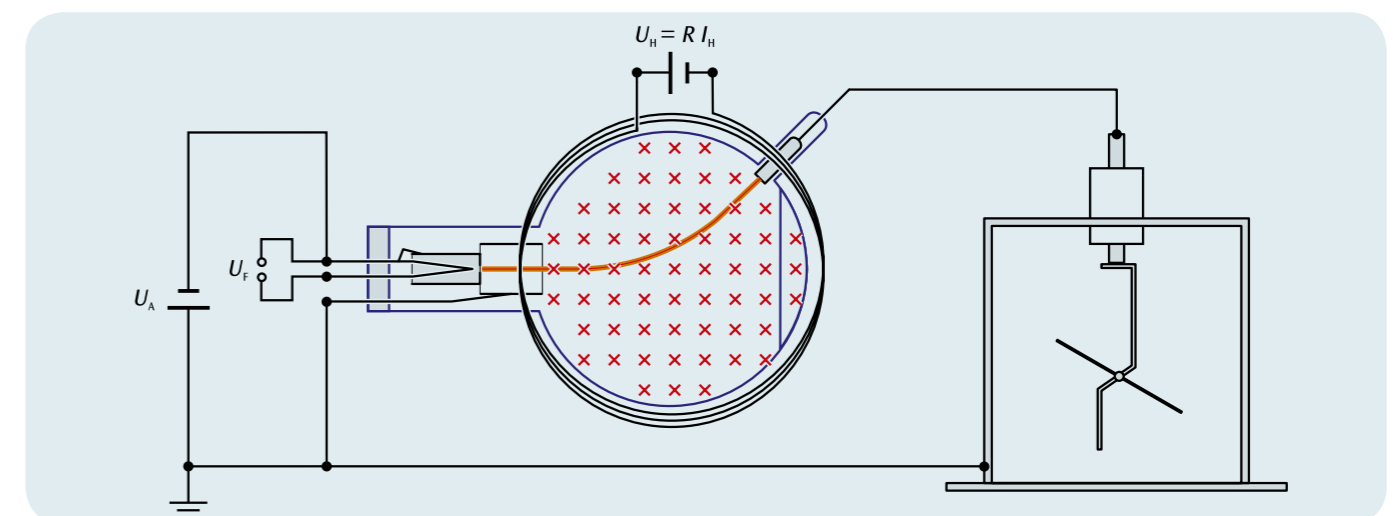

Fig. 1: Schematic diagram of the Perrin tube



EXPERIMENT PROCEDURE

- Investigate the deflection of an electron beam by a magnetic field.
- Estimate the specific charge of an electron.
- Investigate the deflection of an electron beam by an electric field.
- Construct a velocity filter using orthogonal electric and magnetic fields.

OBJECTIVE

Investigate the deflection of electrons by electric and magnetic fields

SUMMARY

In a Thomson tube the vertical deflection of a horizontal electron beam can be observed on a fluorescent screen. Such a deflection can be generated by a vertical electric field or by a horizontal magnetic field that is perpendicular to the direction of motion in the horizontal plane.

REQUIRED APPARATUS

Quantity	Description	Number
1	Thomson Tube S	1000617
1	Tube Holder S	1014525
1	Helmholtz Pair of Coils S	1000611
1	High Voltage Power Supply 5 kV (230 V, 50/60 Hz)	1003310 or
	High Voltage Power Supply 5 kV (115 V, 50/60 Hz)	1003309
1	DC Power Supply 0 – 500 V (230 V, 50/60 Hz)	1003308 or
	DC Power Supply 0 – 500 V (115 V, 50/60 Hz)	1003307
1	Set of 15 Safety Experiment Leads, 75 cm	1002843

2

BASIC PRINCIPLES

In a Thomson tube electrons pass horizontally through a slit behind the anode and impinge upon a fluorescent screen placed at an angle to the electron beam on which they can be observed. Beyond the slot there is a plate capacitor. The electric field between its two plates deflects the electron beam in a vertical direction. In addition Helmholtz coils can be used to create a magnetic field in a horizontal direction perpendicular to the motion of the electrons that also deflects them in a vertical direction.

An electron moving with velocity \mathbf{v} through a magnetic field \mathbf{B} is subject to a Lorentz force given by

$$(1) \quad \mathbf{F} = -e \cdot \mathbf{v} \times \mathbf{B}$$

e : Charge of an electron

The force acts in a direction perpendicular to a plane defined by the direction of motion and the magnetic field. This causes the beam to be deflected vertically, if both the direction of motion and the magnetic field are in the horizontal plane (see Fig. 1). If the direction of motion is perpendicular to a uniform magnetic field, electrons are deflected in a circular path with a centripetal force resulting from the Lorentz-force.

$$(2) \quad m \cdot \frac{v^2}{r} = e \cdot v \cdot B$$

m : Mass of an electron, r : Radius of path.

The velocity of the electrons depends on the anode voltage U_A so that:

$$(3) \quad v = \sqrt{2 \cdot \frac{e}{m} \cdot U_A}$$

This means that measuring the radius of the path allows the specific charge of an electron to be determined as long as the homogenous magnetic field B and the anode voltage U_A are both known. Equations (2) and (3) can be combined to give an expression for the specific charge of an electron:

$$(4) \quad \frac{e}{m} = \frac{2 \cdot U_A}{(B \cdot r)^2}$$

If a voltage U_P is being applied to the plate capacitor, electrons are deflected vertically by its electric field E with a force

$$(5) \quad \mathbf{F} = -e \cdot \mathbf{E}$$

e : Charge of an electron

This deflection is also vertical (see Fig. 2). The electric field can thus be adjusted in such a way that it precisely cancels out the deflection due to the magnetic field:

$$(6) \quad e \cdot E + e \cdot v \cdot B = 0$$

In this case it is easy to determine the velocity of each electron:

$$(7) \quad v = \frac{E}{B}$$

Such an arrangement of orthogonal electric and magnetic fields in which the deflection of the beam, is cancelled out is sometimes called a velocity filter.

EVALUATION

The magnetic field B is generated by a pair of Helmholtz coils and is proportional to the current I_H passing through each coil individually. The coefficient of proportionality k can be determined from the coil radius $R = 68 \text{ mm}$ and the number of turns in the coil $N = 320$ per coil:

$$B = k \cdot I_H \quad \text{where} \quad k = \left(\frac{4}{5}\right)^2 \cdot 4\pi \cdot 10^{-7} \frac{\text{Vs}}{\text{Am}} \cdot \frac{N}{R}$$

The electric field can be calculated from the voltage U_P and the separation of plates d :

$$E = \frac{U_P}{d}$$

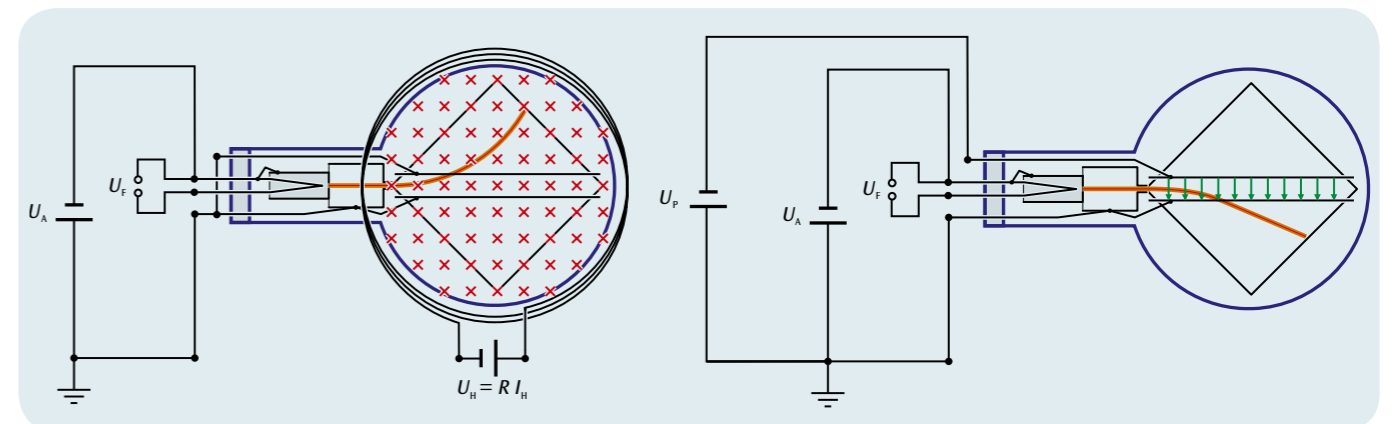

Fig. 1: Schematic of a Thomson tube in a magnetic field

Fig. 2: Schematic of a Thomson tube in an electric field

UE3070700

FINE-BEAM TUBE

UE3070700

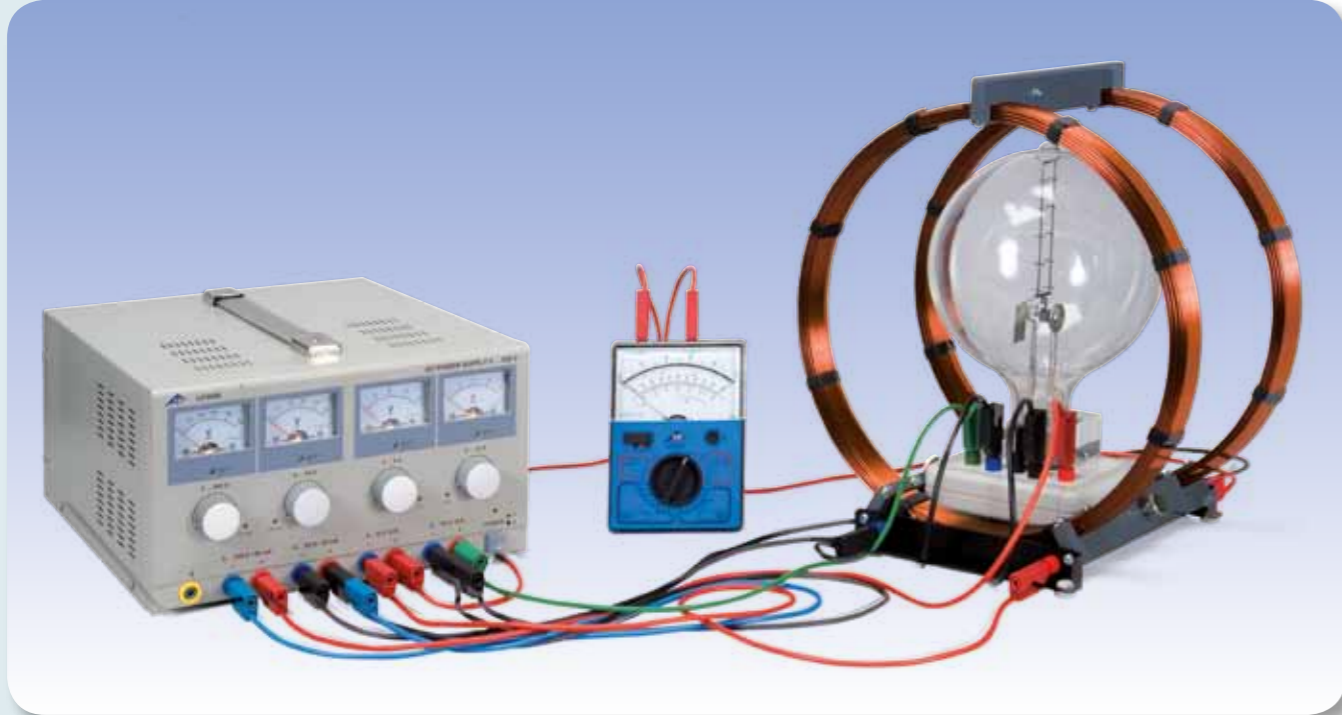

EXPERIMENT PROCEDURE

- Demonstrate the deflection of electrons in a uniform magnetic field into a closed circular path.
- Determine the Helmholtz current I_H as a function of the accelerating voltage of the electron gun U for a constant path radius r .

OBJECTIVE

Determine the specific charge of an electron

SUMMARY

In the fine-beam tube, the path of electrons in a uniform magnetic field can be observed as a clearly delineated ray. This means that the radius of the circular path can be directly measured with a simple ruler. From the path radius r , the magnetic field B and the electron gun's accelerating voltage U the specific charge of an electron e/m can be calculated.

REQUIRED APPARATUS

Quantity	Description	Number
1	Fine Beam Tube on Connection Base	1000904
1	Helmholtz Coils 300 mm	1000906
1	DC Power Supply 0 – 500 V (230 V, 50/60 Hz)	1003308
1	DC Power Supply 0 – 500 V (115 V, 50/60 Hz)	1003307
1	Analogue Multimeter AM50	1003073
1	Set of 15 Safety Experiment Leads, 75 cm	1002843

2

BASIC PRINCIPLES

Electrons in a fine-beam tube are deflected into a circular path by a uniform magnetic field. The tube contains neon gas at a precisely defined pressure so that gas atoms become ionised by collision with electrons along the path thus causing them to emit light. This means the path of the electrons can be viewed directly and the radius of the curvature can simply be measured with a ruler. Since the accelerating voltage of the electron gun U and the magnetic field strength B are both known, the radius of the path r can be used to determine the specific charge of an electron e/m :

An electron moving at velocity v in a direction perpendicular to a magnetic field B is subject to a Lorentz-force that acts in a direction orthogonal to both the movement and the magnetic field:

$$(1) \quad F = e \cdot v \cdot B$$

e : Charge on an electron

This gives rise to a centripetal force on the electron

$$(2) \quad F = \frac{m \cdot v^2}{r}$$

m : Mass of an electron

such that it moves in a circular path of radius r . Therefore

$$(3) \quad e \cdot B = \frac{m \cdot v}{r}$$

The velocity v is dependent on the accelerating voltage U applied to the electron gun:

$$(4) \quad v = \sqrt{2 \cdot \frac{e}{m} \cdot U}$$

Therefore the specific charge of the electron is given by:

$$(5) \quad \frac{e}{m} = \frac{2 \cdot U}{(r \cdot B)^2}$$

EVALUATION

The magnetic field B is generated by a pair of Helmholtz-coils and is proportional to the current I_H that passes through each of the coils. The coefficient of proportionality k can be determined from the coil radius $R = 147.5 \text{ mm}$ and the number of turns in the coil $N = 124$ per coil:

$$B = k \cdot I_H \quad \text{where} \quad k = \left(\frac{4}{5}\right)^{\frac{3}{2}} \cdot 4\pi \cdot 10^{-7} \frac{\text{Vs}}{\text{Am}} \cdot \frac{N}{R}$$

This means that all the components needed to calculate the specific change are known.

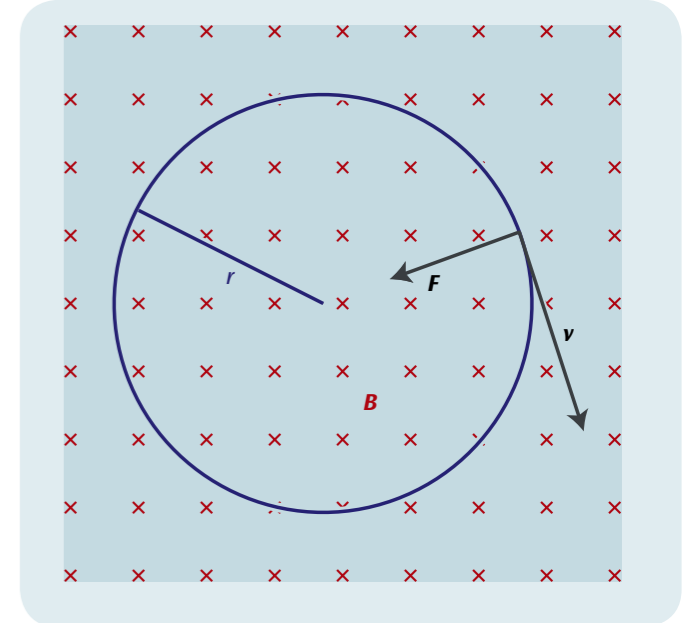

Fig. 1: Deflection of electron of velocity v in a magnetic field B by a Lorentz-force F into a closed circular path of radius r

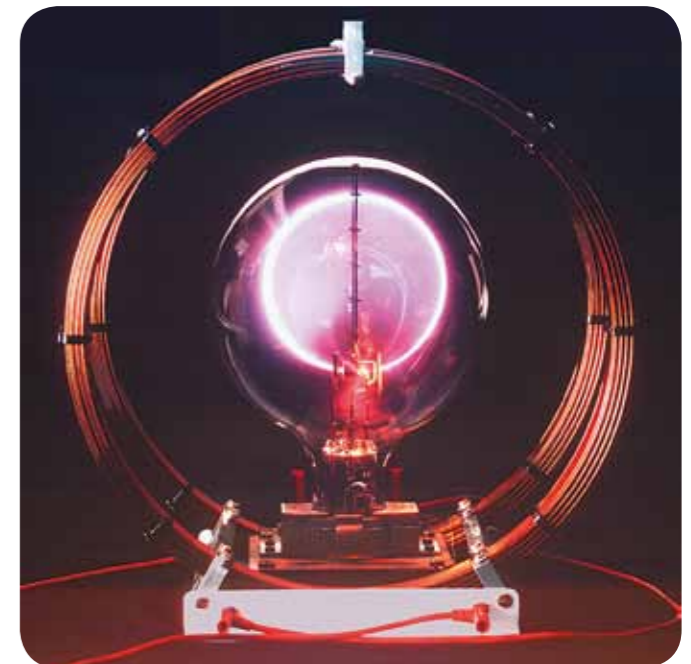
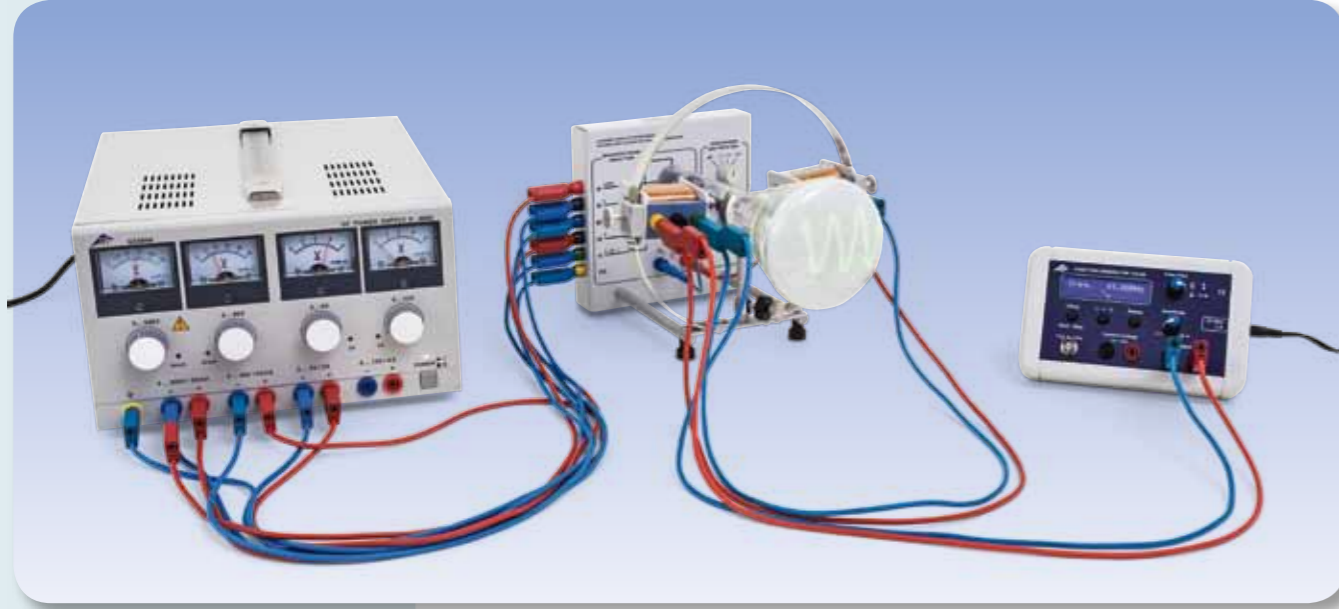

Fig. 2: Fine-beam tube with spherically-shaped luminous trace of electrons in the magnetic field



EXPERIMENT PROCEDURE

- Investigating the deflection of an electron beam in an electric field.
- Investigating the deflection of an electron beam in a magnetic field.
- Demonstrating the display of signals on an oscilloscope, using the periodic signal from a function generator.
- Calibrating the frequency control of the sawtooth generator.

OBJECTIVE

Study the physical principles of the time-resolved display of electrical signals using an oscilloscope

SUMMARY

The student oscilloscope can be used to study the physical principles of the time-resolved display of electrical signals on a fluorescent screen. In a Braun tube, a focused electron beam is generated, and the point at which it falls on the fluorescent screen is observed as a spot of green light. When the electron beam is deflected by a sawtooth voltage applied between a pair of plates, it moves at a constant speed from left to right across the screen, then flies back to the starting point. This process is repeated cyclically at a frequency that can be adjusted. The time-dependent voltage that is to be displayed is applied to a coil outside the tube, so that the beam is deflected vertically in the magnetic field of the coil. The time-dependence of the signal is resolved by the simultaneous horizontal motion of the electron beam and displayed on the fluorescent screen.

REQUIRED APPARATUS

Quantity	Description	Number
1	Training Oscilloscope	1000902
1	DC Power Supply 0 – 500 V (230 V, 50/60 Hz)	1003308 or
	DC Power Supply 0 – 500 V (115 V, 50/60 Hz)	1003307
1	Function Generator FG 100 (230 V, 50/60 Hz)	1009957 or
	Function Generator FG 100 (115 V, 50/60 Hz)	1009956
1	Set of 15 Safety Experiment Leads, 75 cm	1002843

2

BASIC PRINCIPLES

An important application of thermionic emission in a high vacuum is the cathode ray oscilloscope, in which the Braun tube is an essential component. In the form used in the student oscilloscope, the electron-optical system of the Braun tube, which is visible from the outside, consists of a thermionic cathode surrounded by a “Wehnelt cylinder” and a pinhole disc at the anode potential. A proportion of the electrons that are accelerated towards the anode pass through the pinhole disc and form a beam, which is observed on the tube’s fluorescent screen as a green spot of light. Because the tube is filled with neon at a low pressure, the electron beam is concentrated through collisions with gas atoms, and is visible as thin threads emitting reddish light. A negative voltage that is applied to the Wehnelt cylinder also contributes to the concentration of the beam. Technical oscilloscopes usually have additional arrangements for post-acceleration (intensification) and focusing of the beam, but for simplicity and clarity these are not present in the student oscilloscope.

Behind the anode, there is a pair of plates with their planes parallel to the electron beam, which can be connected to a sawtooth generator (see Fig. 1). The electric field produced by the sawtooth voltage $U_x(t)$ deflects the beam horizontally, so that it moves across the fluorescent screen from left to right at a constant speed, then flies back to the starting point. This process is repeated cyclically at a frequency that can be adjusted.

During its left-to-right movement, the electron beam can also be deflected vertically by a magnetic field, and for this a voltage $U_y(t)$ is applied to the coils that are external to the tube. If this voltage is time-dependent, the time-resolved variations are displayed on the screen (see Fig. 2). Such time-dependent voltages might be, for example, the periodic output voltage from a function generator, or the amplified signals from a microphone.

In the experiment, the periodic signals from a function generator are investigated. The most useful display is obtained when the sawtooth frequency is adjusted so that its ratio to that of the function generator is a whole number.

EVALUATION

If the frequencies are adjusted so that exactly one cycle of the signal is displayed on the screen, then its frequency matches that of the sawtooth generator.

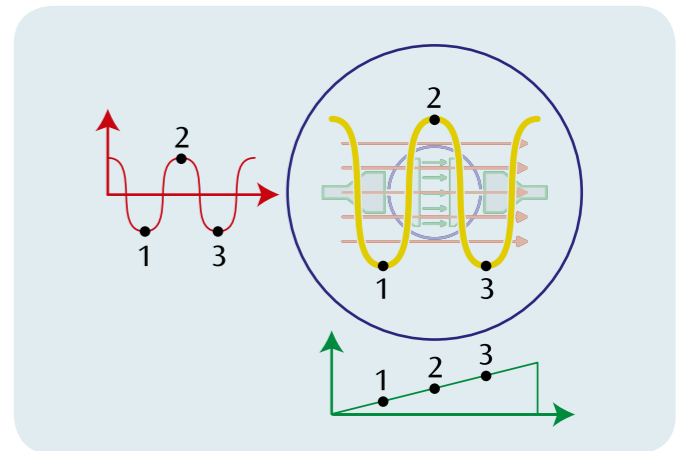

Fig. 2: Time-resolved display of a periodic signal

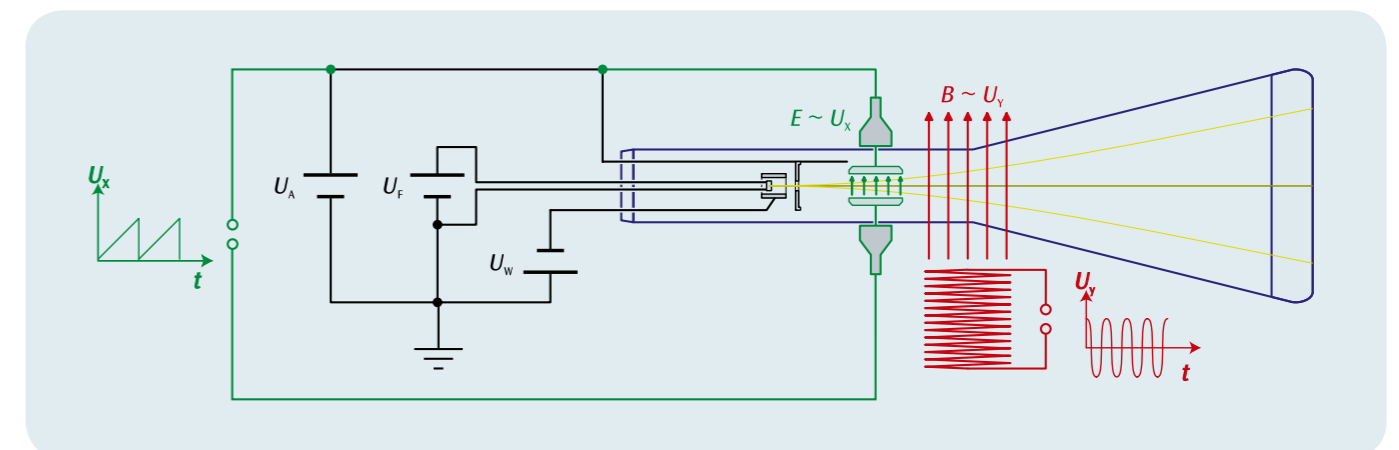

Fig. 1: Schematic diagram of the student oscilloscope, viewed from above



EXPERIMENT PROCEDURE

- Superposing magnetic fields with the same and different frequencies, and observing the displacement of the focused spot on the screen of the tube.
- Generating closed Lissajous' figures.
- Checking the frequency of the mains supply.

OBJECTIVE

Demonstrate the superposition of magnetic fields in a vacuum

SUMMARY

The absence of interference when magnetic fields are superposed in a vacuum is demonstrated using a Braun tube. This is done by observing the displacements of the focused spot on the fluorescent screen of the tube. The experiments can be extended to include alternating magnetic fields with identical and different frequencies. The Lissajous' figures observed on the screen depend critically on the relation between the frequencies of the two magnetic fields and on their phase relation.

REQUIRED APPARATUS

Quantity	Description	Number
1	Training Oscilloscope	1000902
1	DC Power Supply 0 – 500 V (230 V, 50/60 Hz)	1003308 or
	DC Power Supply 0 – 500 V (115 V, 50/60 Hz)	1003307
1	Function Generator FG 100 (230 V, 50/60 Hz)	1009957 or
	Function Generator FG 100 (115 V, 50/60 Hz)	1009956
1	AC/DC Power Supply 0 – 12 V, 3 A, stab. (230 V, 50/60 Hz)	1001007 or
	AC/DC Power Supply 0 – 12 V, 3 A, stab. (115 V, 50/60 Hz)	1001006
1	Set of 15 Safety Experiment Leads, 75 cm	1002843

2

BASIC PRINCIPLES

A Braun tube can be used to demonstrate the principle of superposition for magnetic fields in a vacuum, by observing the deflection of the beam in the magnetic field. It is especially instructive to also perform experiments with alternating magnetic fields, as the electron beam follows the changes of the magnetic field without a significant time-lag.

In the experiment, two identical current-carrying coils are placed outside the Braun tube, and the deflection of the electron beam in the magnetic fields of the coils is observed on the tube's fluorescent screen as shifts of the focused spot. The magnetic field of the horizontal coil causes a vertical shift of the beam, while that of the vertical coil causes a horizontal shift. When an alternating magnetic field at the mains frequency is applied to one of the coils, the focused spot is stretched out to become a vertical or horizontal line. If both coils are then connected in parallel to the alternating voltage source, the screen shows a straight line at 45° to the vertical, whereas when the coils are connected in opposition the line is at -45°, as the shifts produced by the two magnetic fields are superposed.

The experiment can be extended to study the effects of alternating magnetic fields of different frequencies. The Lissajous' figures that then appear on the screen depend critically on the relationship between the frequencies of the two magnetic fields and on their phase relationship. When the ratio of the frequencies is an integer or a simple fraction, closed figures are generated. Their exact shape also depends on the phase difference between the magnetic fields. As an example, Figure 1 shows Lissajous' figures with a frequency ratio 5:1.

If the frequency ratio is only slightly different from a simple rational value, we observe a closed figure that changes with time, at a rate that becomes slower as the difference from a simple ratio is reduced. In the experiment, this behaviour is used to check the mains frequency. For this, one coil is connected to a transformer working at the mains frequency, while the second coil is connected to a signal generator whose output frequency can be read precisely.

EVALUATION

The generator frequency is adjusted relative to the mains frequency ν until we get the frequency ν_5 that gives the slowest change of a Lissajous' figure corresponding to the frequency ratio 5:1.

The mains frequency is then calculated as:

$$\nu = \frac{\nu_5}{5}$$

The measurement has a precision of ± 0.01 Hz, since ν_5 can be adjusted with a precision of ± 0.05 Hz.

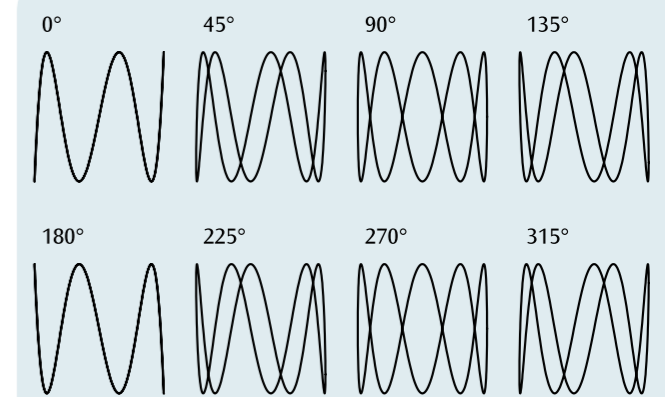

Fig. 1: Lissajous' figures for the frequency ratio 5:1 with phase differences 0°, 45°, 90°, ...



OBJECTIVE

Messung der relevanten Kennlinien eines npn-Transistors

SUMMARY

A bipolar transistor is an electronic component composed of three alternating p-doped and n-doped semiconductor layers called the base, the collector and the emitter. Depending on the sequence of the layers, the transistor may either be termed npn or pnp. The response of a bipolar transistor may be distinctively described by, for example, an input characteristic, a control characteristic and an output characteristic. In this experiment, examples of these are to be measured for an npn transistor, displayed on a graph and evaluated.

EXPERIMENT PROCEDURE

- Measure the input characteristic, i.e. the base current I_B as a function of the base emitter voltage U_{BE} .
- Measure the control characteristic, i.e. the collector current I_C as a function of the base current I_B for a fixed collector-emitter voltage U_{CE} .
- Measure the output characteristic, i.e. the collector current I_C as a function of the collector-emitter voltage for a fixed base current I_B .

REQUIRED APPARATUS

Quantity	Description	Number
1	Plug-In Board for Components	1012902
1	Set of 10 Jumpers, P2W19	1012985
1	Resistor 1 kΩ, 2 W, P2W19	1012916
1	Resistor 47 kΩ, 0.5 W, P2W19	1012926
1	Potentiometer 220 Ω, 3 W, P4W50	1012934
1	Potentiometer 1 kΩ, 1 W, P4W50	1012936
1	NPN Transistor, BD 137, P4W50	1012974
1	AC/DC Power Supply 0 – 12 V, 3 A (230 V, 50/60 Hz)	1002776 or
	AC/DC Power Supply 0 – 12 V, 3 A (115 V, 50/60 Hz)	1002775
3	Analogue Multimeter AM50	1003073
1	Set of 15 Experiment Leads, 75 cm 1 mm ²	1002840

BASIC PRINCIPLES

A bipolar transistor is an electronic component composed of three alternating p-doped and n-doped semiconductor layers called the base B, the collector C and the emitter E. The base is between the collector and emitter and is used to control the transistor. In principle a bipolar transistor resembles two diodes facing opposite directions and sharing an anode or cathode. Bipolarity arises from the fact that the two varieties of doping allow for both electrons and holes to contribute to the transport of charge.

Depending on the sequence of the layers, the transistor may either be termed npn or pnp (Fig. 1). Bipolar transistors are operated as quadripoles in three basic circuits, distinguished by the arrangement of the terminals and called common emitter, common collector and common base. The names indicate which of the terminals is common to both the input and the output.

Only npn transistors are considered in the following treatment.

There are four operating modes for an npn transistor, depending on whether the base-emitter or base-collector junctions are aligned in a conducting or forward-bias direction ($U_{BE}, U_{BC} > 0$) or a non-conducting or reverse bias ($U_{BE}, U_{BC} < 0$) direction (see Table 1). In forward-bias mode, electrons from the emitter migrate into the base across the transistor's forward-biased base-emitter junction ($U_{BE} > 0$) while holes from the base move into the emitter. Since the emitter has much higher doping than the

base, more electrons will migrate than holes, which minimises recombination between the two. Because the width of the base is shorter than the diffusion length of the electrons, which count as minority carriers within the base itself, the electrons diffuse through the base into the depletion layer between the base and the collector before drifting further towards the collector itself. This is because the depletion layer only forms a barrier for majority carriers. This results in a transfer current I_T from the emitter into the collector, which is the major contributor to the collector current I_C in forward-bias mode. The transistor can therefore be regarded as a voltage controlled current source whereby the I_C at the output can be controlled by the voltage U_{BE} at the input. Electrons which recombine in the base emerge from there in a base current I_B which guarantees a constant transfer current I_T , thereby ensuring that the transistor remains stable. A small input current I_B can therefore control a much greater output current I_C ($I_C \approx I_T$), which gives rise to current amplification.

The response of a bipolar transistor is described by four characteristics, the input characteristic, the control or base characteristic, the output characteristic and the feedback characteristic (see Table 2). This experiment involves measuring, by way of example, input, control and output characteristics for an npn transistor and plotting them as a graph.

Tab. 1: Four operating modes of an npn transistor

U_{BE}	U_{BC}	Operating mode
> 0	< 0	Normal mode
> 0	> 0	Saturation
< 0	> 0	Inverse mode
< 0	< 0	Off state

Tab. 2: Four characteristics of an npn transistor in normal mode

Name	Dependency	Parameter
Input characteristic	$I_B(U_{BE})$	
Control characteristic	$I_C(I_B)$	$U_{CE} = \text{const.}$
Output characteristic	$I_C(U_{CE})$	$I_B = \text{const.}$
Feedback characteristic	$U_{BE}(U_{CE})$	$I_B = \text{const.}$

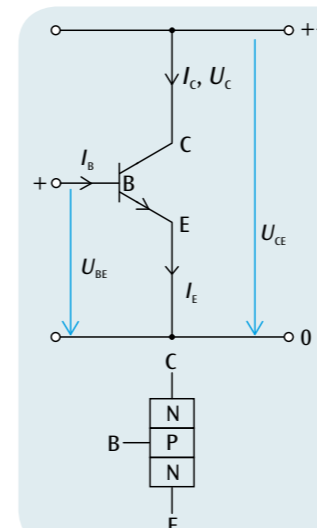

Fig. 1: Design of an npn transistor in principle, including accompanying circuit symbol plus indications of voltage and current

EVALUATION

The threshold voltage U_{Th} can be found from the input characteristic and the gain can be found from the control characteristic

$$B = \frac{\Delta I_C}{\Delta I_B}$$

The power dissipation can be found from the output characteristic $P = U_{CE} \cdot I_C$.

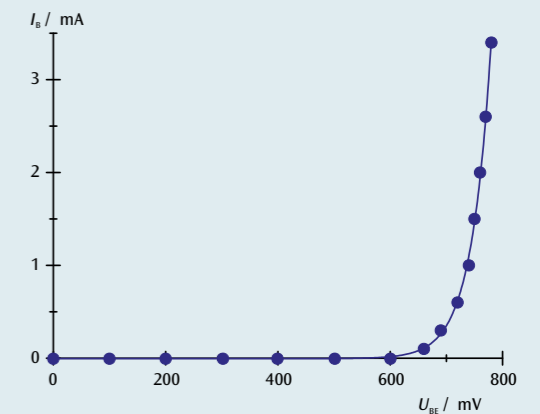

Fig. 2: Input characteristic

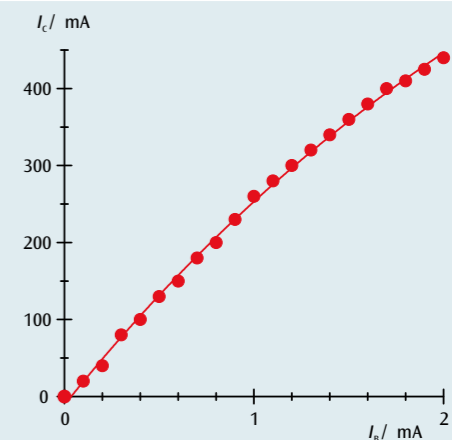

Fig. 3: Control characteristic for $U_{CE} = 5.2$ V

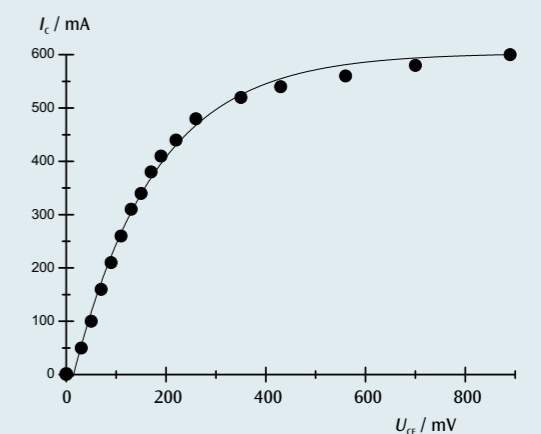
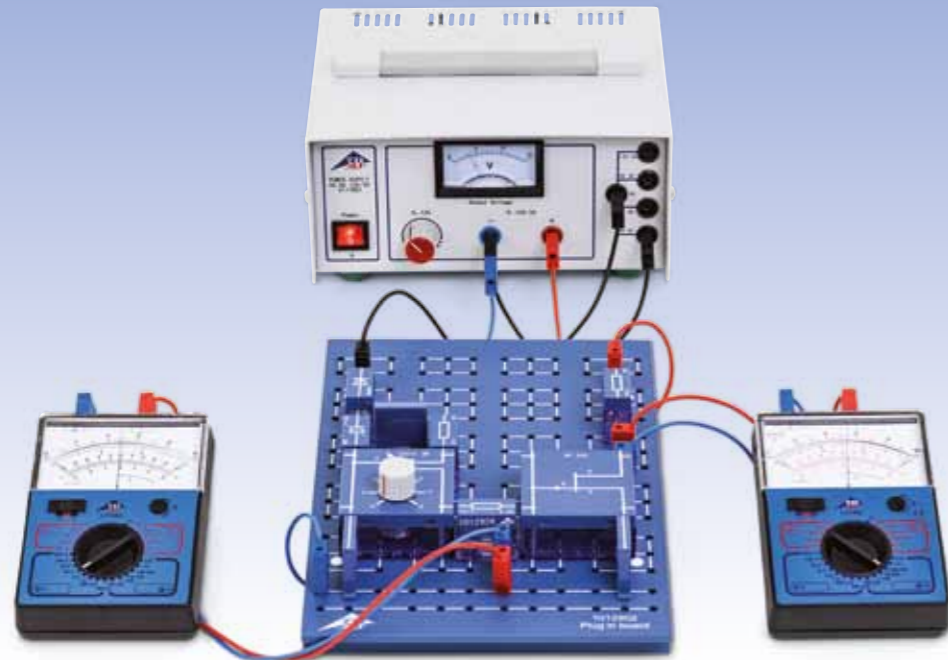

Fig. 4: Output characteristic for $I_B = 4.2$ mA





EXPERIMENT PROCEDURE

- Measure the drain voltage as a function of the drain current for various voltages at the gate.

OBJECTIVE

Measure the characteristics of a field effect transistor

SUMMARY

A field effect transistor (FET) is a semiconductor component in which electric current passes through a channel and is controlled by an electric field acting perpendicular to the channel. FETs have three contacts, called source, drain and gate due to their respective functions. If a voltage is applied between the source and the drain, then a drain current flows between the two. For small voltages between the drain and source, an FET acts like a simple ohmic resistor with a correspondingly linear characteristic. As the source-drain voltage increases, the channel becomes restricted and eventually is cut off entirely. The characteristic then enters an area of saturation. When the gate voltage is non-zero, the saturation value of the drain current decreases.

REQUIRED APPARATUS

Quantity	Description	Number
1	Plug-In Board for Components	1012902
1	Set of 10 Jumpers, P2W19	1012985
1	Resistor 1 k Ω , 2 W, P2W19	1012916
1	Resistor 470 Ω , 2 W, P2W19	1012914
1	Resistor 47 k Ω , 0.5 W, P2W19	1012926
1	Capacitor 470 μ F, 16 V, P2W19	1012960
1	FET Transistor, BF 244, P4W50	1012978
1	Silicon Diode, 1N 4007, P2W19	1012964
1	Potentiometer 220 Ω , 3 W, P4W50	1012934
1	AC/DC Power Supply 0 – 12 V, 3 A (230 V, 50/60 Hz)	1002776 or
	AC/DC Power Supply 0 – 12 V, 3 A (115 V, 50/60 Hz)	1002775
2	Analogue Multimeter AM50	1003073
1	Set of 15 Experiment Leads, 75 cm 1 mm ²	1002840

2

BASIC PRINCIPLES

A field effect transistor (FET) is a semiconductor component in which electric current passes through a channel and is controlled by an electric field acting perpendicular to the channel.

FETs have three contacts, called source (S), drain (D) and gate (G) due to their respective functions. The channel comprises a conductive link between the source and the drain. If a voltage U_{DS} is applied between source and drain, a drain current I_D flows in the channel. The current is carried by carriers of only one polarity (unipolar transistors), i.e. electrons for an n-doped semiconductor channel and holes in a p-doped channel. The cross-section or the conductivity of the channel is controlled by the electric field perpendicular to the channel. To create this field, a gate voltage U_{GS} is applied between the source and gate. The gate electrode is isolated from the channel by means of a reverse-biased pn junction or by an extra insulating layer (IGFET, MISFET, MOSFET). For insulated gate FETs the cross section of the channel is controlled by the expansion of the space-charge region of the junction, which is itself controlled by the perpendicular field. In order to ensure that the pn junction is always reverse-biased, i.e. specifically to make sure that there is no current at the gate, the gate voltage U_{GS} and the drain-source voltage U_{DS} must meet the following condition for an n-channel FET

$$(1a) \quad U_{GS} \leq 0, U_{DS} \geq 0$$

and the following for a p-channel FET

$$(1b) \quad U_{GS} \geq 0, U_{DS} \geq 0.$$

If the absolute value of the drain-source voltage $|U_{DS}|$ is small, the FET acts like an ohmic resistor with a correspondingly linear characteristic. As $|U_{DS}|$ increases, the channel is restricted in size because the reverse-bias voltage between the gate and the channel increases in the direction of the drain. The space-charge region near the drain is wider than that near the source, meaning that the channel is narrower near the drain than it is near the source. At a specific voltage where $U_{DS} = U_p$ the width of the channel becomes zero and the drain current no longer increases even though the drain-source voltage is increased. The characteristic passes out of its ohmic region into a region of saturation.

The extent of the space-charge region and therefore the size of the channel can be controlled by means of the gate voltage. As long as the gate voltage is non-zero, the channel can undergo additional constriction, making the drain-source current smaller and, in particular, the saturation current lower. The channel remains blocked irrespective of the drain-source voltage U_{DS} when $|U_{GS}| \geq |U_p|$.

The experiment involves measuring drain current I_D as a function of drain-source voltage U_{DS} for various gate voltages U_{GS} .

EVALUATION

The measurements are plotted on a graph of I_D against U_{DS} for various values of the gate voltage U_{GS} (Fig. 1). This should verify the shape of the characteristic showing how the drain current is controlled by the drain-source voltage and gate voltage.

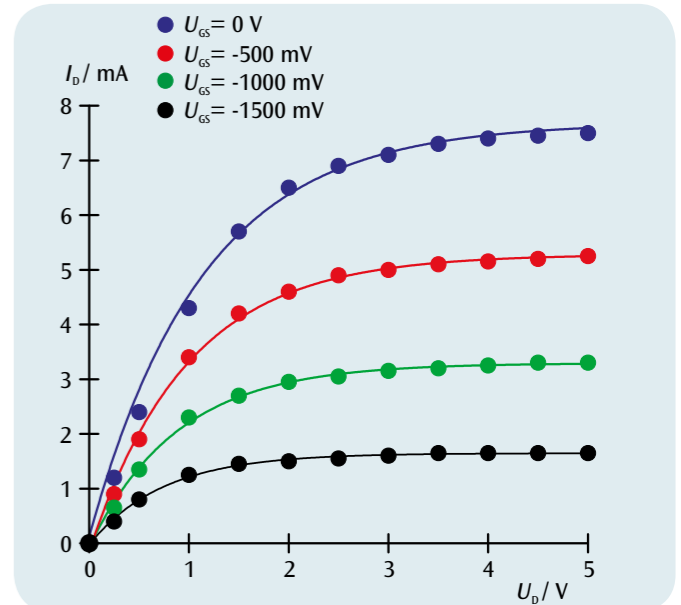
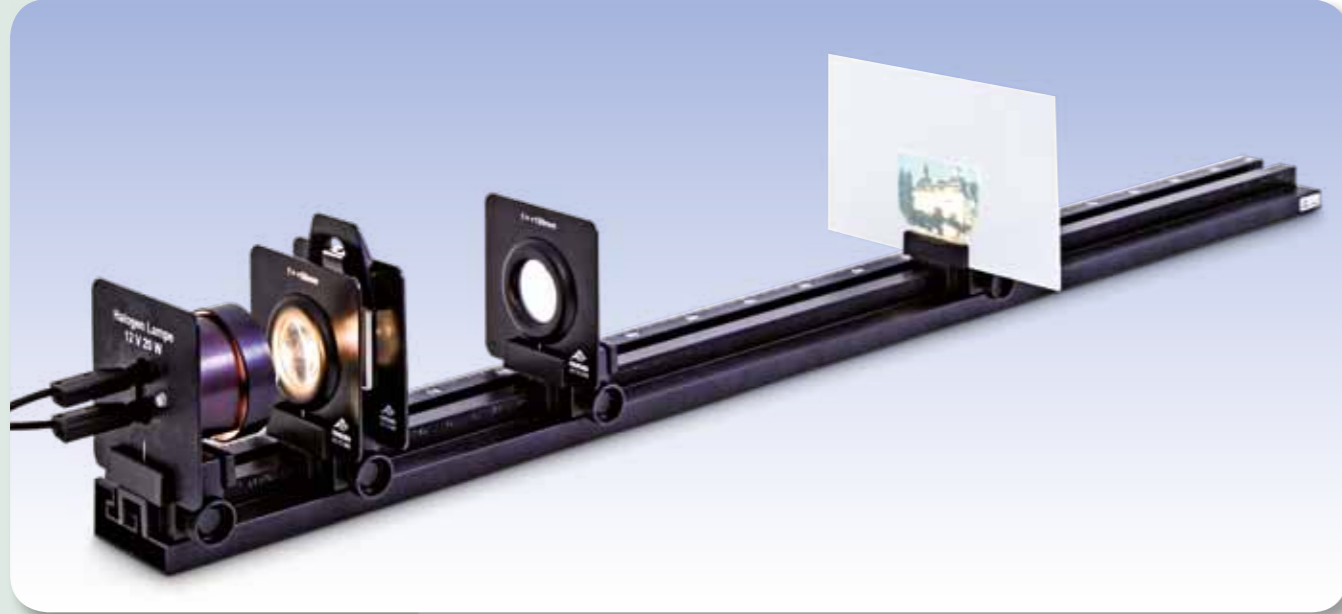

Fig. 1: Characteristic curve for FET with gate voltages 0 V (blue), -0.5 V (red), -1 V (green) and -1.5 V (turquoise)



EXPERIMENT PROCEDURE

- Determine the two positions of a thin lens where a sharp image is formed.
- Determine the focal length of a thin lens.

OBJECTIVE

Determine the focal length of a lens using the Bessel method

SUMMARY

On an optical bench it is possible to set up a light source, a lens, a screen and an object to be imaged in such a way that a well focussed image appears on the screen. Using the geometric relationships between the ray paths for a thin lens, it is possible to determine its focal length.

REQUIRED APPARATUS

Quantity	Description	Number
1	Optical Bench K, 1000 mm	1009696
4	Optical Rider K	1000862
1	Optical Lamp K	1000863
1	Transformer 12 V, 25 VA (230 V, 50/60 Hz)	1000866 or
	Transformer 12 V, 25 VA (115 V, 50/60 Hz)	1000865
1	Convex Lens K, $f = 50$ mm	1000869
1	Convex Lens K, $f = 100$ mm	1010300
1	Clamp K	1008518
1	Set of 4 Image Objects	1000886
1	Projection Screen K, White	1000879

1

BASIC PRINCIPLES

The focal length f of a lens refers to the distance between the main plane of the lens and its focal point, see Fig.1. This can be determined using the Bessel method (devised by Friedrich Wilhelm Bessel). This involves measuring the various separations between the optical components on the optical bench.

From Fig.1 and Fig. 2 it can be seen that the following relationship must apply for a thin lens:

$$(1) \quad a = b + g$$

a : distance between object G and image B
 b : distance between lens and image B
 g : distance between object G and lens

By plugging these values into the lens equation

$$(2) \quad \frac{1}{f} = \frac{1}{b} + \frac{1}{g}$$

f : focal length of lens

the following is obtained:

$$(3) \quad \frac{1}{f} = \frac{a}{a \cdot g - g^2}$$

This corresponds to a quadratic equation with the following pair of solutions:

$$(4) \quad g_{1,2} = \frac{a}{2} \pm \sqrt{\frac{a^2}{4} - a \cdot f}$$

A sharp image is obtained for each of the object distances g_1 and g_2 . The difference e between them allows the focal length to be determined:

$$(5) \quad e = g_1 - g_2 = \sqrt{a^2 - 4af}$$

The difference e is the difference between the two lens positions P_1 and P_2 , which result in a focussed image.

EVALUATION

A formula for the focal length of a thin lens can be derived using the

Bessel method from equation (4) $f = \frac{a^2 - e^2}{4a}$

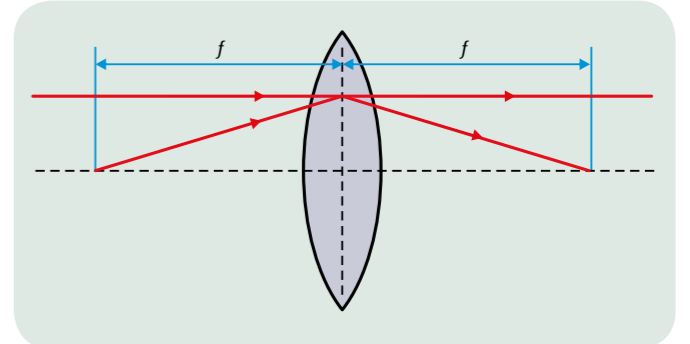

Fig. 1: Schematic showing the definition of focal length for a thin lens

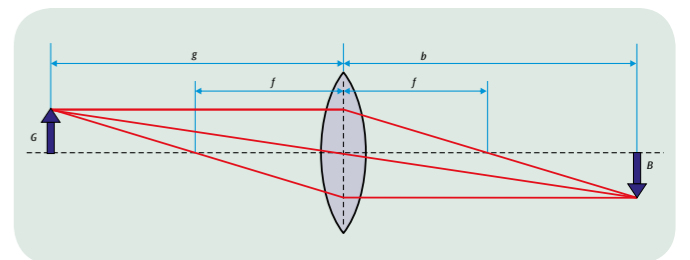

Fig.2: Schematic of ray paths through a lens

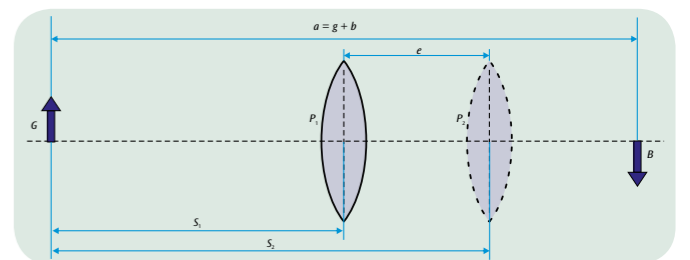

Fig.3: Schematic showing the two lens positions which result in a well focussed image on the screen



EXPERIMENT PROCEDURE

- Measure and compare the transmission spectra of solid bodies.
- Measure and compare the transmission spectra of liquids.

OBJECTIVE

Record and interpret transmission spectra of transparent bodies

SUMMARY

A digital spectrophotometer is used to measure transmission spectra. In this instrument the transmitted light collected by an optical fibre is separated into its spectral components by a reflection grating using the Czerny-Turner principle and is projected as an image onto a CCD detector via two mirrors. The transmission spectrum is generated by automatic normalisation applied to the previously recorded spectrum of the light falling on the detector.

REQUIRED APPARATUS

Quantity	Description	Number
1	Digital-Spectrometer LD	1018103
1	Absorption module	1018105
1	Set of 7 Colour Filters	1003084
1	Macro cuvettes, 4ml	1018106
Additionally recommended:		
	Chlorophyll	
	Potassium Permanganate	

1

BASIC PRINCIPLES

The observed colour of an object illuminated with white light depends on its reflecting properties. The perceived colour of light that has passed through an object depends on its light transmitting properties. For example, the perceived colour may be red if the object is transparent to red light while other colour components of the light are attenuated on passing through the object. In such a case spectral transmission is at a maximum for red light.

The unaided human eye cannot distinguish between a colour sensation caused by spectrally pure light and the same sensation caused by the addition of neighbouring colours of the spectrum. Therefore, it is not possible to reach conclusions about the transmission spectrum solely from the observed colour. To determine it unambiguously is only possible with the help of a spectrometer.

In this experiment, transmission spectra are recorded using a digital spectrophotometer. In this instrument the transmitted light collected by an optical fibre is separated into its spectral components by a reflection grating using the Czerny-Turner principle and is projected as an image onto a CCD detector via two mirrors. The transmission spectrum is generated by automatic normalisation applied to the previously recorded spectrum of the light falling on the detector.

EVALUATION

Spectral absorptivity $A(\lambda)$ can be calculated directly from the spectral transmission coefficient $T(\lambda)$ of a body if the effect of reflection at the surface is neglected. The relationship is:

$$A(\lambda) = 1 - T(\lambda)$$

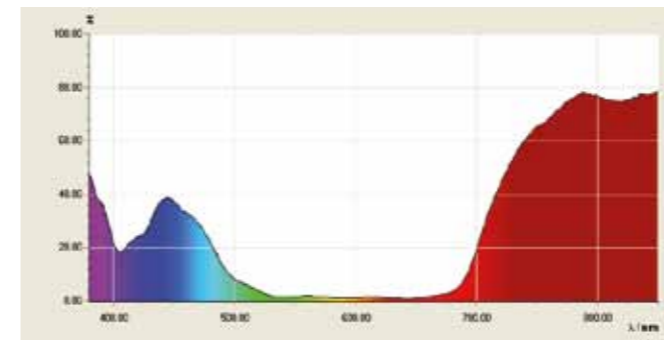

Fig. 1: Transmission spectra of a blue colour film

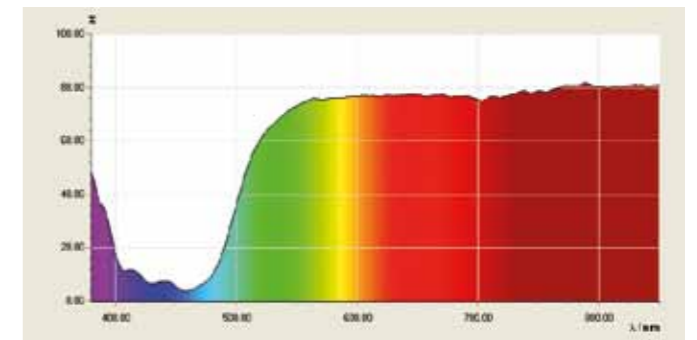

Fig. 2: Transmission spectra of a yellow colour film

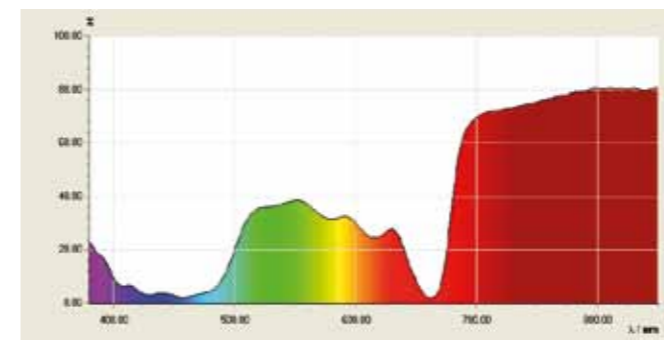

Fig. 3: Transmission spectrum of a chlorophyll solution

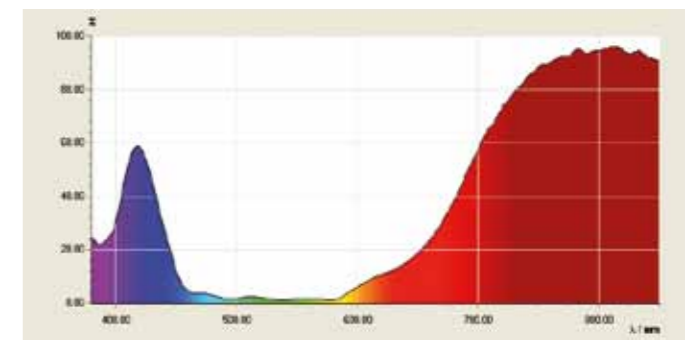
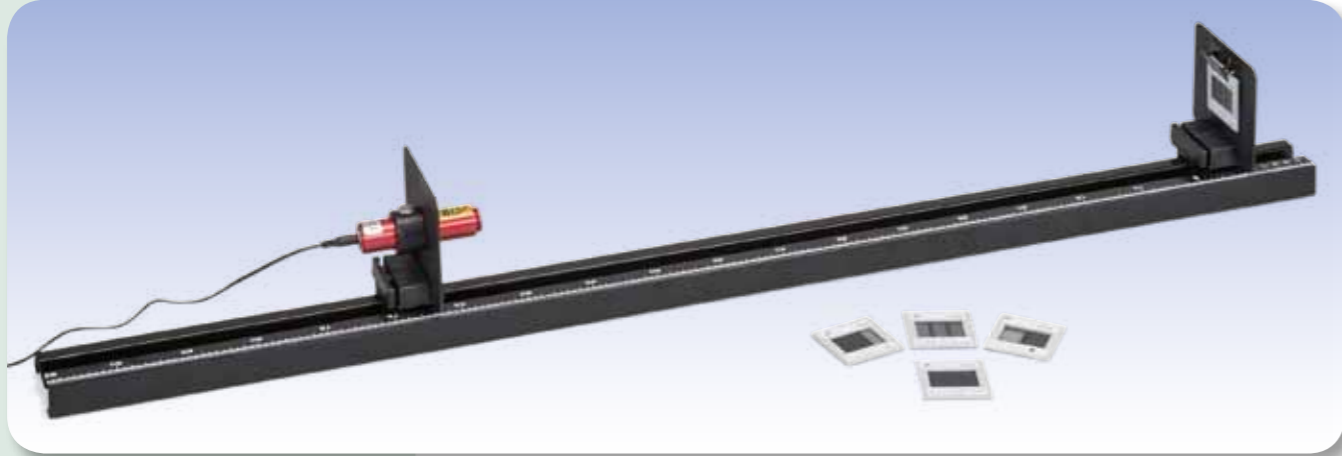

Fig. 4: Transmission spectrum of a potassium permanganate solution



EXPERIMENT PROCEDURE

- Investigate diffraction at a pair of slits with different distances between the slits.
- Investigate diffraction at a pair of slits with different slit widths.
- Investigate diffraction by multiple slit systems with different numbers of slits.
- Investigate diffraction by a line grating and a lattice grating.

OBJECTIVE

Demonstrate the wave nature of light and determine the wavelength

SUMMARY

The diffraction of light by multiple slits or a grating can be described by considering how the individual components of the coherent wave radiation are superimposed as they emerge from the various slits, which can each be regarded as a single point of illumination so that the waves superimpose according to Huygens principle. The interference of the individual waves explains the pattern of bright and dark bands that is observed beyond the system of slits. If the the separation between the slits and the distance to the observation screen is known, the wavelength of the light can be calculated from the distance between any two bright bands.

REQUIRED APPARATUS

Quantity	Description	Number
1	Laser Diode, Red	1003201
1	Optical Bench K, 1000 mm	1009696
2	Optical Rider K	1000862
1	Clamp K	1008518
1	Holder K for Diode Laser	1000868
1	Diaphragm with 3 Double Slits of Different Widths	1000596
1	Diaphragm with 4 Double Slits of Different Spacings	1000597
1	Diaphragm with 4 Multiple Slits and Gratings	1000598
1	Diaphragm with 3 ruled gratings	1000599
1	Diaphragm with 2 cross gratings	1000601

BASIC PRINCIPLES

The diffraction of light by multiple slits or a grating can be described by considering the superimposition of individual components of the coherent wave radiation, which emerge from each point of illumination formed by the multiple slits, according to the Huygens principle. The superimposition leads to constructive or destructive interference in particular directions, and this explains the pattern of bright and dark bands that is observed beyond the system of slits.

In the space beyond a pair of slits, the light intensity at a particular angle of observation α_n is greatest when, for each individual wave component coming from the first slit, there exists an exactly similar wave component from the second slit, and the two interfere constructively. This condition is fulfilled when the

path difference Δs_n between two wave components emerging from the centres of the two slits is an integral multiple of the wavelength λ of the light (see Fig. 1), thus:

$$(1) \quad \Delta s_n(\alpha_n) = n \cdot \lambda$$

$n = 0, \pm 1, \pm 2, \dots$: is called the diffraction order.

At large distances L from the pair of slits and for small angles of observation α_n , the relationship between the path difference Δs_n and the position coordinate x_n of the n th-order intensity maximum is:

$$(2) \quad \frac{\Delta s_n}{d} = \sin \alpha_n \approx \tan \alpha_n = \frac{x_n}{L}$$

d : Distance between the slits.

Thus the maxima are spaced at regular intervals with a separation a given by:

$$(3) \quad a = x_{n+1} - x_n = \frac{\lambda}{d} \cdot L$$

This relationship is also valid for diffraction at a multiple slit system consisting of N equidistant slits ($N > 2$). Equation (1) states the condition for constructive interference of the wave elements from all N slits. Therefore, Equations (2) and (3) can also be applied to a multiple slit system.

The mathematical derivation of the positions of the intensity minima is more difficult. Whereas in the case of a pair of slits there is an intensity minimum exactly halfway between two intensity maxima, for the multiple slits system a minimum is observed between the n th and the $(n+1)$ th maxima when the wave components from the N slits interfere in such a way that the total intensity is zero. This occurs when the path difference between the wave components from the centres of the slits satisfies the condition:

$$(4) \quad \Delta s = n \cdot \lambda + m \frac{\lambda}{N}$$

$$n = 0, \pm 1, \pm 2, \dots, m = 1, \dots, N - 1$$

Therefore $N-1$ minima are visible and between them are $N-2$ "minor maxima" with intensities smaller than those of the principal maxima. As the number of slits N is progressively increased, the contribution of the minor maxima gradually disappears. Then the system is no longer described as a multiple slit system but as a line grating. Finally, a lattice grating can be regarded as an arrangement of two line gratings, one rotated at 90° relative to the other. The diffraction maxima now become points on a rectangular grid with a spacing interval given by Equation (3). The intensity (brightness) of the principal maxima is modulated according to the intensity distribution function for diffraction at a single slit. The greater the slit width b , the greater the concentration of intensity towards smaller values of the angle α . For an exact derivation it is necessary to sum the amplitudes of all the wave components, taking into account the path differences, to obtain the total amplitude A . At a point on the screen defined by x , the intensity is:

$$(5) \quad I = A^2 \propto \left(\frac{\sin\left(\frac{\pi \cdot b \cdot x}{\lambda \cdot L}\right)}{\frac{\pi \cdot b \cdot x}{\lambda \cdot L}} \right)^2 \cdot \left(\frac{\sin\left(N \cdot \frac{\pi \cdot d \cdot x}{\lambda \cdot L}\right)}{\sin\left(\frac{\pi \cdot d \cdot x}{\lambda \cdot L}\right)} \right)^2$$

EVALUATION

The wavelength λ of the diffracted light can be determined from the separation a between the principal maxima, and is given by:

$$\lambda = d \cdot \frac{a}{L}$$

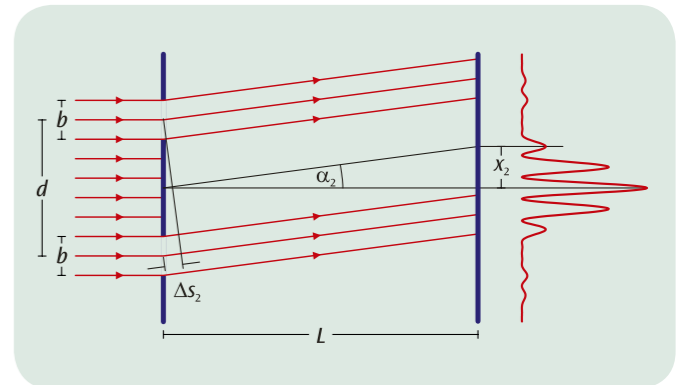

Fig. 1: Schematic diagram of the diffraction of light at a pair of slits

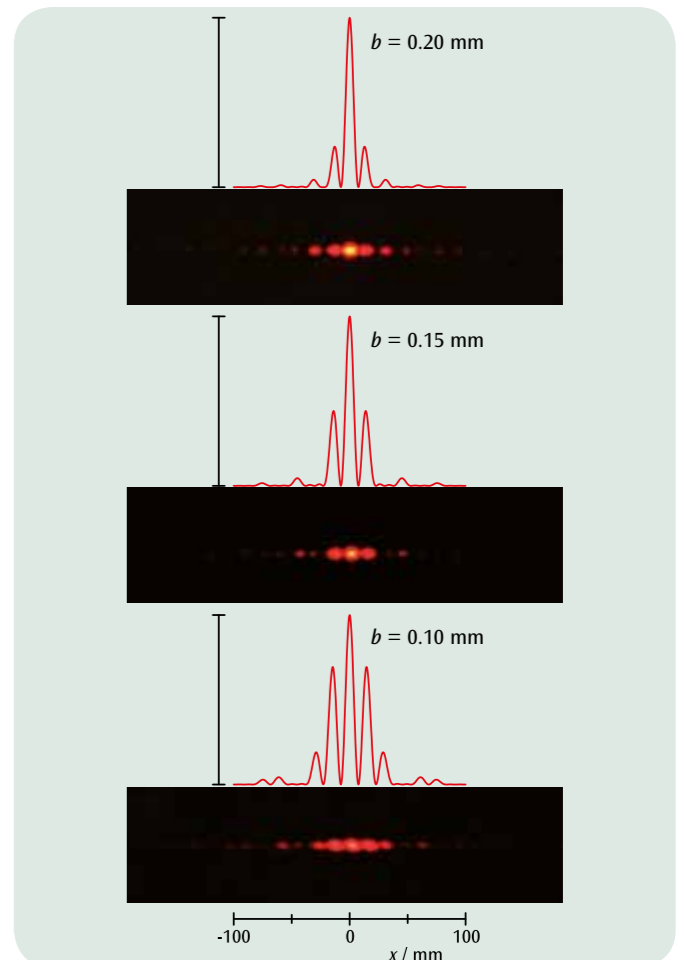
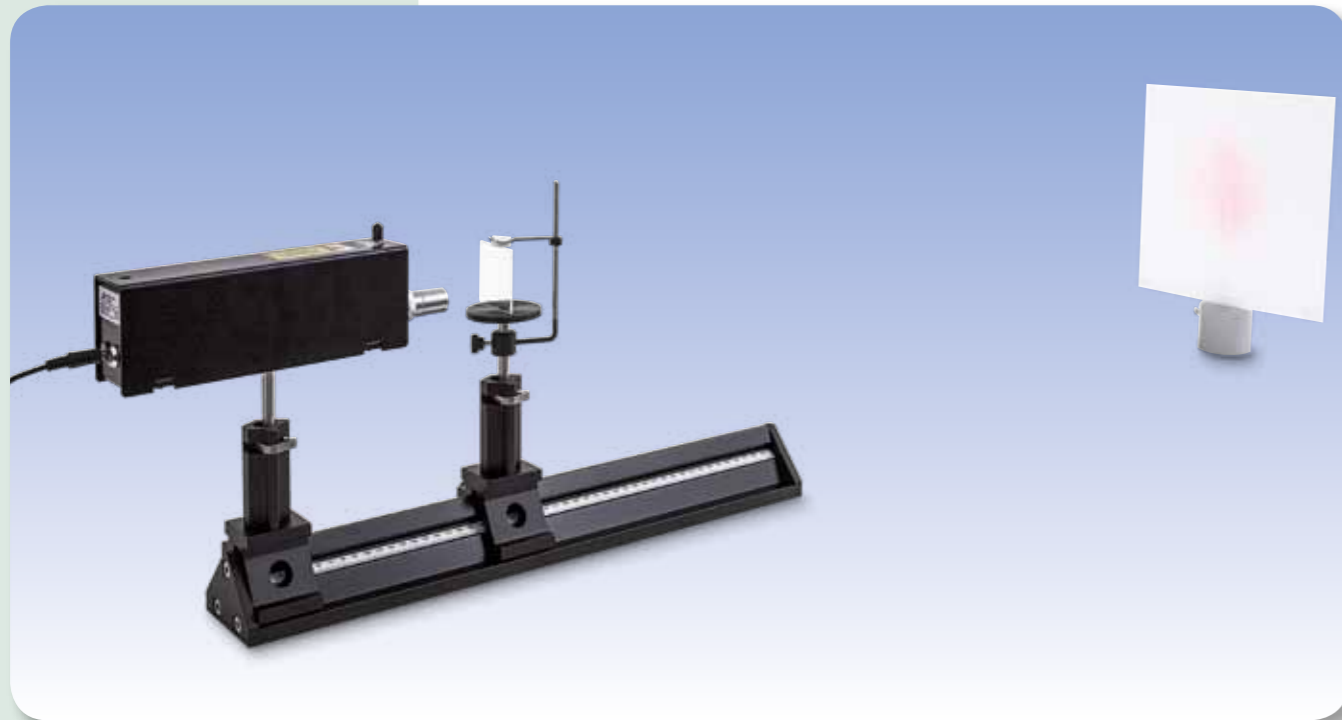

Fig. 2: Calculated and observed intensities for diffraction at a pair of slits with different distances between the slits



EXPERIMENT PROCEDURE

- Use a Fresnel biprism to create two virtual coherent sources of light from a single point light source.
- Observation of the interference between the two split beams from the virtual light sources.
- Determine the wavelength of light from an He-Ne laser from the separation between interference bands.

OBJECTIVE

Generating interference between two beams using a Fresnel biprism

SUMMARY

Refraction of a divergent light beam by means of a biprism separates the beam into two parts which, since they are coherent, will interfere with one another. The wavelength of the light used in the experiment can be determined using the separation of the virtual light sources and the distance between adjacent interference bands.

REQUIRED APPARATUS

Quantity	Description	Number
1	Fresnel Biprism	1008652
1	Prism Table on Stem	1003019
1	He-Ne Laser	1003165
1	Achromatic Objective 10x / 0.25	1005408
1	Convex Lens on Stem $f = +200$ mm	1003025
3	Optical Rider D, 90/50	1002635
1	Optical Precision Bench D, 50 cm	1002630
1	Projection Screen	1000608
1	Barrel Foot, 1000 g	1002834
1	Pocket Measuring Tape, 2 m	1002603

2

BASIC PRINCIPLES

In one of his experiments on interference, August Jean Fresnel used a biprism to induce interference between two beams. He split a diverging beam of light into two parts by using the biprism to refract them. This resulted in two split beams which acted as if they were from two coherent sources and which therefore interfered with each other. By observing on a screen, he was able to see a series of peaks in the light intensity with a constant distance between them.

Whether a peak occurs in the intensity or not depends on the difference Δ in the path travelled by each of the split beams. If the light source is a long distance L from the screen, the following is true to a good approximation:

$$(1) \quad \Delta = A \cdot \frac{x}{L}$$

Here, x refers to the coordinate of the point observed on the screen which is perpendicular to the axis of symmetry. A is the distance between the two virtual light sources, which is yet to be determined. Peaks in intensity occur at the precise points where the difference in the path travelled is a multiple of the wavelength λ :

$$(2) \quad \Delta_n = n \cdot \lambda, \text{ where } n = 0, 1, 2, \dots$$

A comparison between (1) and (2) shows that the peaks will be at the following coordinates:

$$(3) \quad x_n = n \cdot D$$

They should also be at a constant distance D apart. The following relationship is also true:

$$(4) \quad \lambda = A \cdot \frac{D}{L}$$

Equation (4) can be seen as an expression for determining the wavelength λ of the light being used. It is always applicable for interference between two beams.

Nevertheless, it is still to be established how the distance between the two virtual sources A can be measured. This can be assisted by a simple optical set-up, in which an image of both sources is obtained on the screen with the help of a converging lens so that the distance B between the images of the two sources can be measured (see Fig. 2). The following then applies:

$$(5) \quad A = B \cdot \frac{a}{b}$$

a : Object distance, b : Image distance.

NOTE

Instead of a biprism, a Fresnel mirror (1002649) can also be used to generate the two virtual light sources. The corresponding list of accessories can be found under the entry for UE4030320.

EVALUATION

In this experiment a laser is used as the source of the light. Its beam is spread out by a lens. The position of the light source is not precisely known, therefore the object distance a is not known either. It therefore needs to be calculated from the focal length f of the lens and the easily measured image distance b using the law for the formation of images:

The following therefore applies: $\frac{1}{f} = \frac{1}{a} + \frac{1}{b}$

The distances D and L can be measured directly. This means that all the variables for determining the wavelength using equation (3) are now known.

$$A = a \cdot \frac{B}{b} = \frac{f \cdot B}{b - f}$$

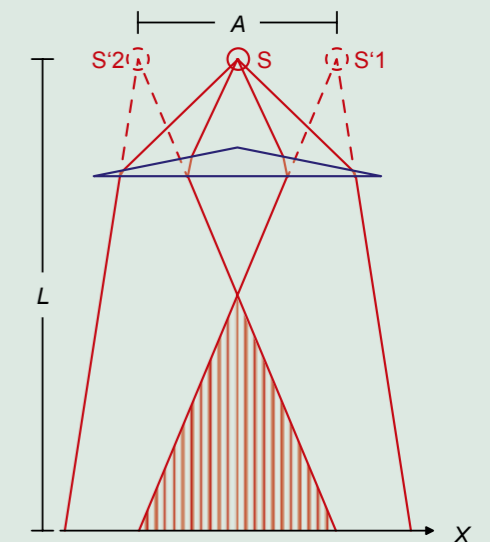

Fig. 1 : Schematic diagram of light passing through a biprism

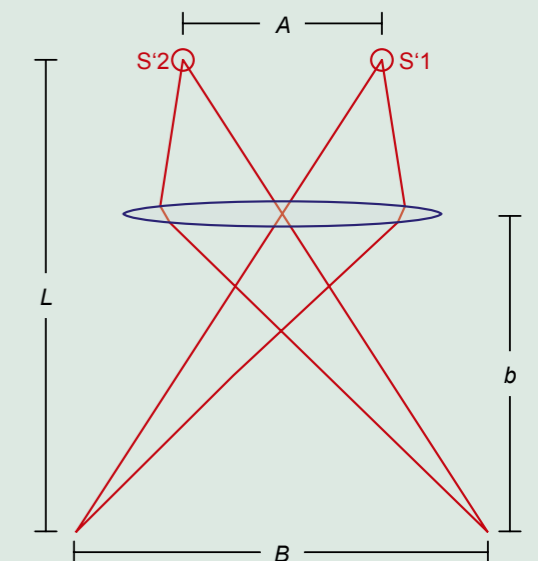
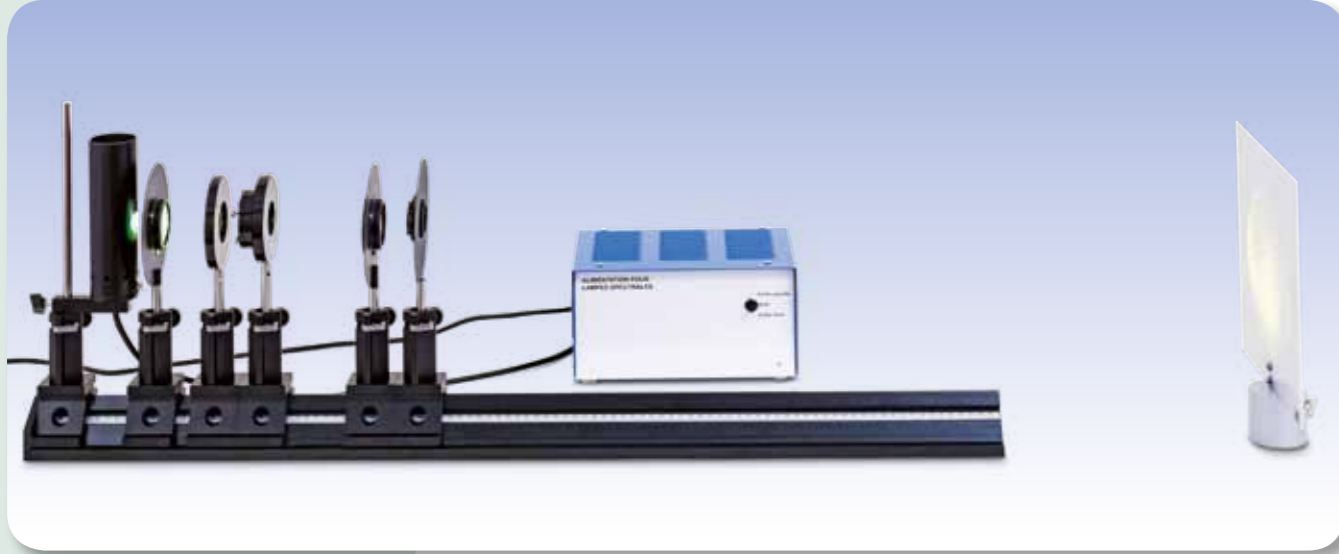

Fig. 2: Ray diagram for obtaining an image of the two virtual sources on the screen



EXPERIMENT PROCEDURE

- Observe Newton's rings with monochromatic light transmitted through the apparatus.
- Measure the radius of the rings and determine the radius of curvature of the spherical body.
- Determine by how much the set up is deformed by the sphere pressing down on the plate.

OBJECTIVE

Observe Newton's rings in monochromatic light

SUMMARY

Newton's rings are generated by a set-up involving a flat glass plate and a spherical body with a large radius of curvature. If parallel monochromatic light is incident on the set-up from an angle normal to the apparatus, alternating light and dark concentric rings are generated, centred on the point where the surfaces meet. In this experiment Newton's rings are investigated using monochromatic light transmitted through the apparatus. The radius of curvature R of the spherical body can be determined from the radii r of the interference rings as long as the wavelength λ is known.

REQUIRED APPARATUS

Quantity	Description	Number
1	Optical Precision Bench D, 100 cm	1002628
6	Optical Rider D, 90/50	1002635
1	Control Unit for Spectrum Lamps (230 V, 50/60 Hz)	1003196 or
	Control Unit for Spectrum Lamps (115 V, 50/60 Hz)	1003195
1	Spectral Lamp Hg 100	1003545
1	Convex Lens on Stem $f = +50$ mm	1003022
1	Convex Lens on Stem $f = +100$ mm	1003023
1	Iris on Stem	1003017
1	Glass Inset for Newton's Rings Experiments	1008669
1	Component Holder	1003203
1	Interference Filter 578 nm	1008672
1	Interference Filter 546 nm	1008670
1	Projection Screen	1000608
1	Barrel Foot, 1000 g	1002834
1	Pocket Measuring Tape, 2 m	1002603

2

BASIC PRINCIPLES

Newton's rings are a phenomenon which can be viewed on a daily basis. They arise due to interference in light reflecting from the upper and lower boundaries of an air gap between two very nearly parallel surfaces. In white light, this produces colourful interference, since the condition for a maximum in the interference is dependent on the wavelength.

In order to deliberately generate Newton's rings, a set-up is used which involves a flat glass plate and a spherical body with a large radius of curvature. The spherical body touches the flat glass plate in such a way that an air gap results. If parallel monochromatic light is incident on the set-up from an angle normal to the apparatus, alternating light and dark concentric rings are generated, centred on the point where the surfaces meet. The darker rings are caused by destructive interference while the light ones result from constructive interference. The light waves reflected from the boundary between the spherical body and the air interfere with ones reflected from the boundary between the flat plate and the air. The interference rings can be viewed in both reflected and transmitted light. With transmission, though, the interference is always constructive at the centre, regardless of the wavelength of the incident light. The separation between the interference rings is not constant. The thickness d of the air gap varies in proportion to the distance r from the point of contact between body and plate. The following can be seen from Fig. 1:

$$(1) \quad R^2 = r^2 + (R \cdot d)^2$$

R : radius of curvature

This means that when the thickness d is small, the following applies for the bright interference rings:

$$(2) \quad d = \frac{r^2}{2 \cdot R} = (n-1) \cdot \frac{\lambda}{2},$$

Therefore the radii of the bright rings are given by

$$(3) \quad r^2 = (n-1) \cdot R \cdot \lambda.$$

It may be seen that the spherical body is slightly deformed at the point of contact. By rearranging equation (2) an approximation of this can be derived from the following expression:

$$(4) \quad d = \frac{r^2}{2 \cdot R} - d_0 \quad \text{for } r^2 \geq 2 \cdot R \cdot d_0$$

Therefore the radii of the bright rings are now given by:

$$(5) \quad r_i^2 = (n-1) \cdot R \cdot \lambda + 2 \cdot R \cdot d_0$$

This experiment investigates Newton's rings using transmitted light from a mercury lamp which has been rendered monochromatic with the aid of interference filters. The interference pattern is focussed onto the screen with the help of an objective lens.

EVALUATION

To determine the radius r , an average is taken of the measured radius values for the crossover point to the left and right. The magnification due to the lens is also taken into account.

Values for r^2 are then plotted as a function of $n-1$, whereby the measurements lie on straight lines of gradients $a = R \cdot \lambda$ which cross the axes at $b = 2 \cdot R \cdot d_0$. Since the wavelengths are known, it is possible to calculate the radius of curvature R . This is approximately 45 m. The flattening d_0 of the sphere due to it pressing down on the plate is less than one micrometer.

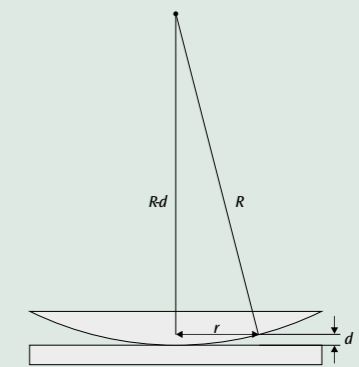

Fig. 1: Schematic illustration of the air gap between the convex lens and the flat plate

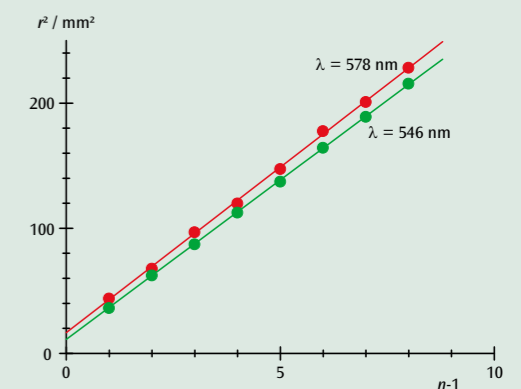

Fig. 2: Relationship between radii r^2 of bright interference rings and their number in sequence n

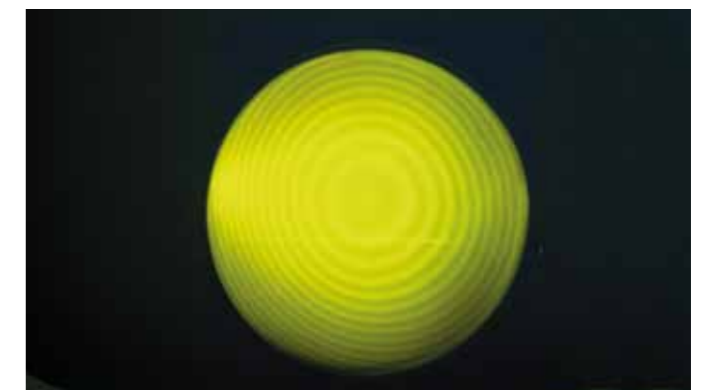
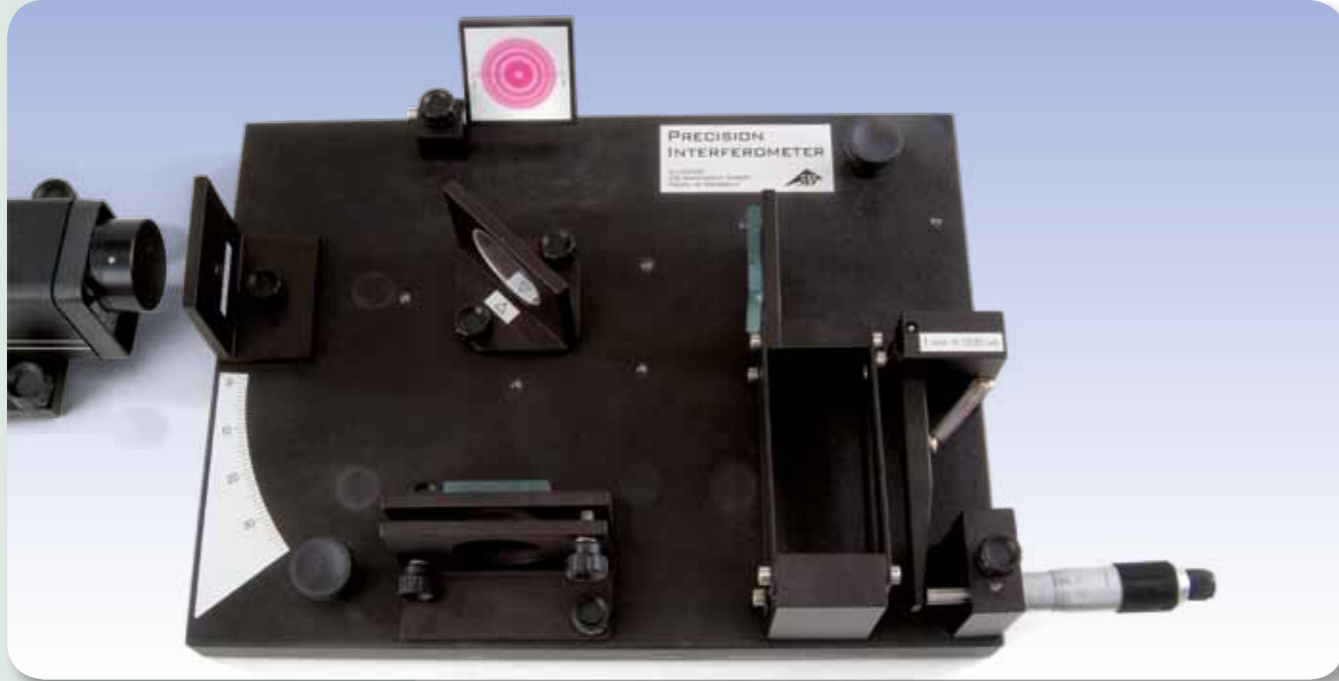

Fig. 3: Newton's rings in yellow light



EXPERIMENT PROCEDURE

- Determine the wavelength of laser light.
- Determine the refractive index of air as a function of pressure.
- Determine the refractive index of glass.
- Determine the quality of the surface of a strip of adhesive tape.

OBJECTIVE

Demonstrate and investigate how a Michelson interferometer works

SUMMARY

In a Michelson interferometer a coherent light beam is separated into two rays travelling in different directions by inserting a half-silvered mirror in the path. The separated beams are reflected back along themselves and then recombined. The viewing screen then exhibits an interference pattern that changes perceptibly when the optical path lengths for each of the split beams are changed by fractions of the wavelength of light.

REQUIRED APPARATUS

Quantity	Description	Number
1	Interferometer	1002651
1	Accessory Set for the Interferometer	1002652
1	He-Ne Laser	1003165
1	Vacuum Hand Pump	1012856
1	Tubing, Silicone 6 mm	1002622



Glass plate in the beam path of the Michelson-interferometer.



Vacuum chamber in the beam path of the Michelson-interferometer.

2

BASIC PRINCIPLES

The Michelson interferometer was invented by A. A. Michelson originally to demonstrate whether the Earth could be observed to be in motion through an ether in which light was once thought to propagate. His design (see Fig. 1) has nevertheless proved crucial for making interferometric measurements, e.g. of changes in length, thickness of layers or refractive indices.

A divergent light beam is split into two by a half-silvered mirror and the two resulting beams travel along differing paths. They are then reflected back on themselves and recombined so that interference patterns can be viewed on a screen. The resulting pattern is highly sensitive to any differences in the optical paths covered by the split beams. If the refractive index remains constant the degree of change in the geometric paths can be calculated, e.g. changes in size of various materials due to thermal expansion. If by contrast the geometry is maintained, then refractive indices or changes in them due to pressure, temperature or density variations may be determined.

Depending on whether the optical paths are increased or decreased in length, interference lines may appear or disappear in the centre of the pattern. The relationship between the change Δs in the optical paths and the wavelength λ is as follows

$$(1) \quad 2 \cdot \Delta s = z \cdot \lambda$$

The number z is a positive or negative integer corresponding to the number of interference lines appearing or disappearing on the screen.

If the wavelength of light in air is to be measured by moving one of the two mirrors by a carefully defined distance Δx by means of a fine adjustment mechanism, the refractive index can be assumed to be $n = 1$ to a good approximation. The change in the optical path is thus:

$$(2) \quad \Delta s = \Delta x$$

The situation is different if an evacuated chamber of length d is inserted into only one of the split beams. By allowing air to pass into the vessel until the pressure rises to a value p , the optical path changes as follows

$$(3) \quad \Delta s = (n(p) - 1) \cdot d = A \cdot p \cdot d$$

This is because the refractive index of air at constant temperature varies with pressure in a fashion that can be represented in the following form:

$$(4) \quad n(p) = 1 + A \cdot p$$

NOTE

The supplementary kit contains a glass plate. This can be placed in the path of one light beam and rotated to a specific angle so that the portion of the optical path that passes through the glass increases while that portion of the path outside the glass decreases. The resulting change in the optical path allows the refractive index of glass to be determined. It is also possible to demonstrate the surface quality of a strip of adhesive tape attached to the glass. In practice such experiments are performed using a *Twyman-Green*-interferometer, which is a variant of the Michelson-interferometer.

EVALUATION

Solving Equations (1) and (2) for wavelength gives an equation for the wavelength that depends on the change in position of the mirror:

$$\lambda = \frac{2 \cdot \Delta x}{z}$$

Determining the refractive index of air: The coefficient A that appears in Equation (4) can be calculated using the following equation

$$A = \frac{z \cdot \lambda}{2 \cdot d \cdot p}$$

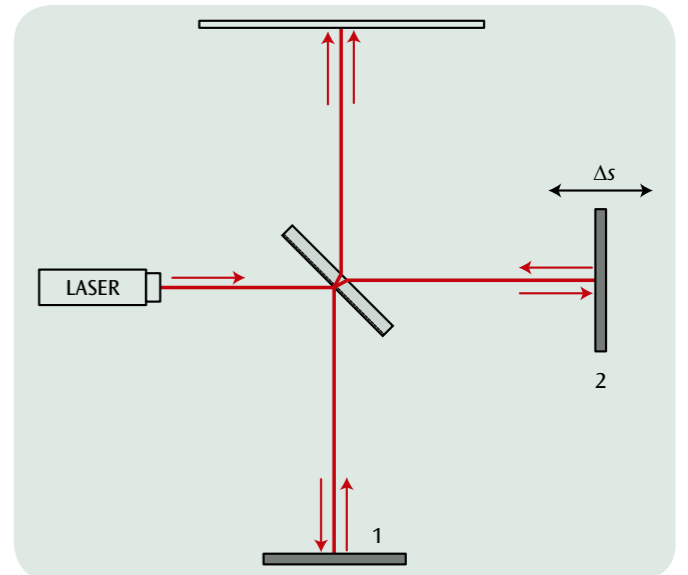

Fig. 1: Optical paths in a Michelson interferometer with a movable mirror

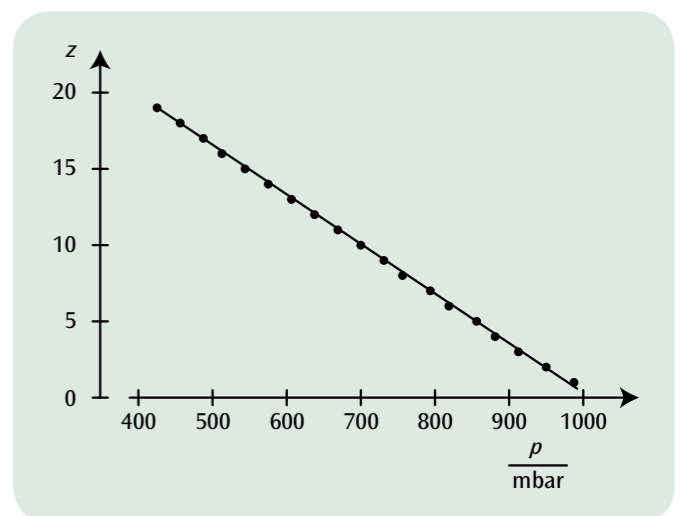
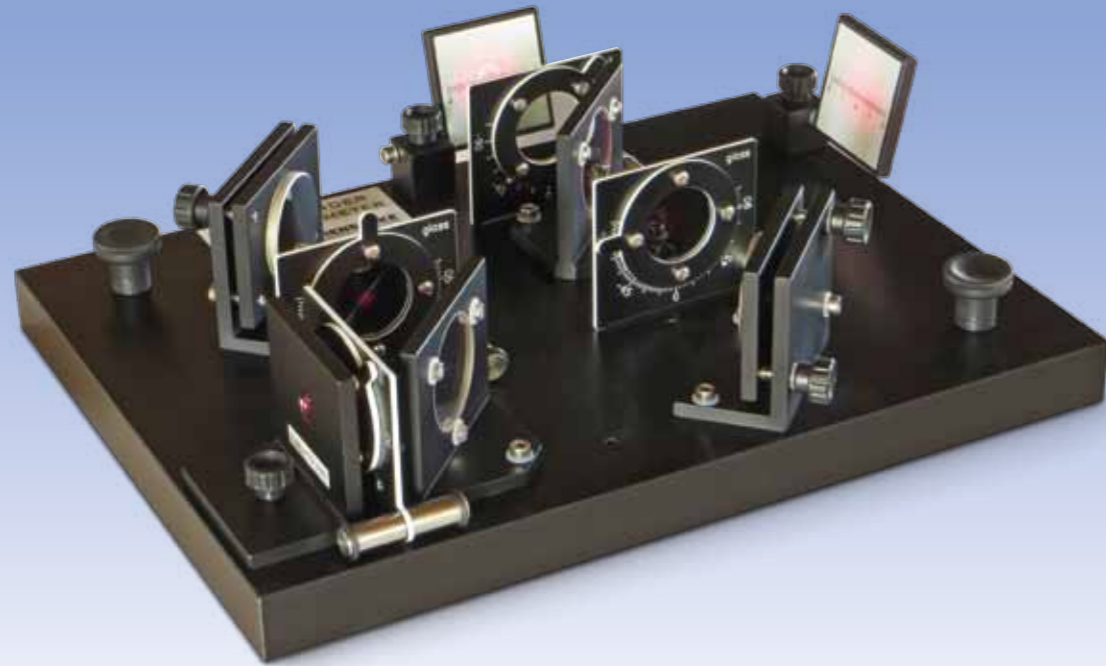

Fig. 2: Number of interference lines as a function of air pressure



EXPERIMENT PROCEDURE

- Set up and calibrate a Mach-Zehnder interferometer
- Observe the interference pattern when the information is available, unavailable and “erased”.

OBJECTIVE

Demonstration of “quantum erasure” in an experiment by analogy

SUMMARY

Light itself can be described in quantum mechanics by means of wave equations. From this it is possible to derive the spatial distribution of the probability density in the form of the square of the modulus of the wave function. Light is therefore suitable for experiments which demonstrate quantum mechanical phenomena by analogy. Such an analogy experiment demonstrates the so-called quantum eraser effect by setting up a Mach-Zehnder interferometer and observing interference between the split beams on a screen. If two perpendicular polarisers are placed in the paths of the split beams, the interference vanishes since, in quantum mechanical terms, it is possible to determine the path a photon has taken. If a third polarising filter set at an angle of 45° is placed directly in front of the screen, this quantum information is “erased” and the interference can be seen once again.

REQUIRED APPARATUS

Quantity	Description	Number
1	Mach-Zehnder Interferometer	1014617
1	He-Ne-Laser	1003165

BASIC PRINCIPLES

Light itself can be described in quantum mechanics by means of wave equations. From this it is possible to derive the spatial distribution of the probability density in the form of the square of the modulus of the wave function. The combination of two beams corresponds to superposition of two wave functions. The probability density then contains a mixed term which describes the interference pattern. Light is therefore suitable for experiments which demonstrate quantum mechanical phenomena by analogy.

2

To demonstrate the so-called quantum eraser effect by means of an analogy experiment, a Mach-Zehnder interferometer is used. Coherent light is provided by letting light from a laser be diverged. With the help of beam splitter BS1, the light is divided into two split beams. Polariser P ensures that both split beams have the same light intensity (see Fig. 1). The two beams then follow different paths but are then brought back into superposition by a second beam splitter BS2.

In terms of conventional wave optics, the electrical fields of the two split beams E_1 and E_2 are then added together:

$$(1) \quad E = E_1 + E_2$$

In quantum mechanical terms, their wave functions Ψ_1 and Ψ_2 can also be summed as follows:

$$(2) \quad \Psi = \Psi_1 + \Psi_2$$

Therefore

$$(3) \quad |E|^2 = |E_1|^2 + |E_2|^2 + 2 \cdot E_1 \cdot E_2$$

and

$$(4) \quad |\Psi|^2 = |\Psi_1|^2 + |\Psi_2|^2 + 2 \cdot \langle \Psi_1 | \Psi_2 \rangle$$

The mixed terms in equations (3) and (4) both describe the interference pattern which can be observed on a screen. Equation 4 describes the behaviour of an individual photon. Such a photon interferes with ‘itself’ as long as it is observed by any process of measurement or if it is not possible to observe the actual path it has travelled. It is said with regard to this that “in the absence of information regarding its path, a photon behaves as a wave and exhibits interference”. If information regarding the path taken is available, however, the photon “behaves” like a classical particle and it is not possible for interference to occur.

Two additional polarisers P1 and P2 placed in the paths of the split beams 1 and 2 cause the interference pattern to be affected. If the polarisers are aligned at right angles to one another, the scalar product $E_1 \cdot E_2$ vanishes in the classical description of equation (3), as does the interference term $\langle \Psi_1 | \Psi_2 \rangle$ in the quantum mechanical representation of Equation (4). This results in the disappearance of the interference pattern. In the quantum mechanical case, this is because the polarisation means that it is possible to specifically determine which path, path 1 or path 2, has been taken by each photon.

However, if a third polariser A, aligned at 45° to the others, is placed behind the second beam splitter, the interference pattern reappears. In quantum mechanical terms, this is so because polariser A “erases” the path information, i.e. beyond polariser A it is no longer possible to determine which path has been taken by any individual photon. In the classical representation, the third polariser would be expected to dim the polarised split beams but they would be expected to retain their polarisation.

EVALUATION

In the absence of both polarisers, P1 and P2, there will be no information available regarding the path taken by the light and interference therefore occurs. Once the two polarisers are employed, it is possible to distinguish paths and interference does not occur.

The third polariser, A, “erases” the path information and interference occurs once more.

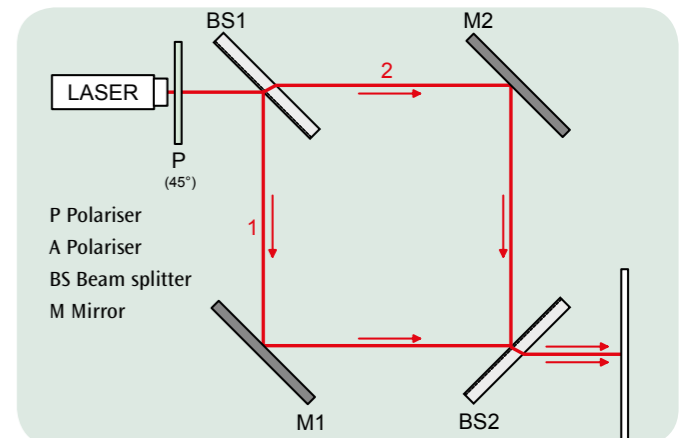

Fig. 1: Paths through the Mach-Zehnder interferometer (no path information)

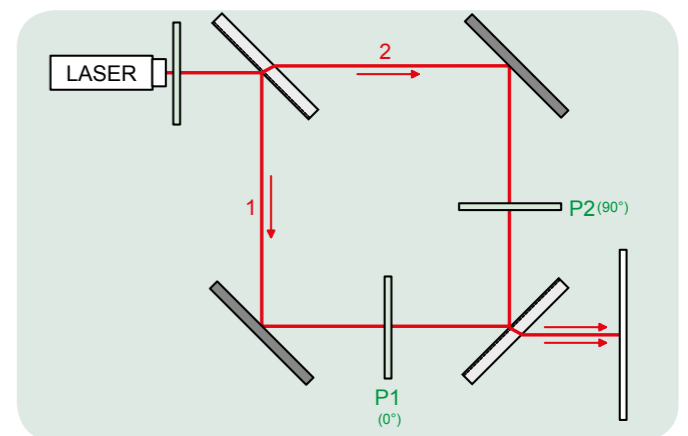

Fig. 2: Paths through the Mach-Zehnder interferometer (polarisers P1 and P2 placed in the two split beams means path information can be obtained)

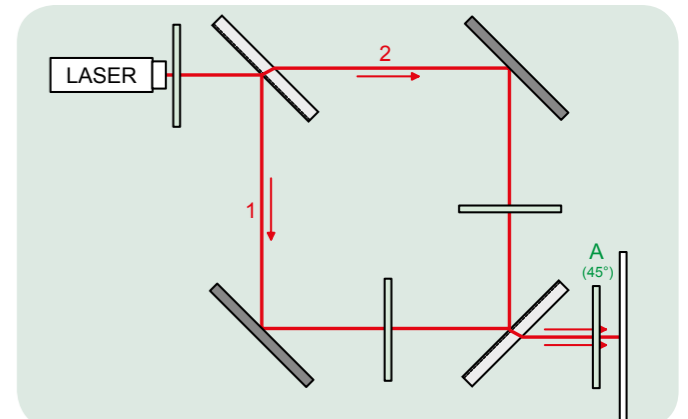

Fig. 3: Paths through the Mach-Zehnder interferometer (polariser A “erases” the path information)



EXPERIMENT PROCEDURE

- Measure the intensity of light I transmitted through a polarising filter as a function of the angle of rotation of the filter.
- Verify Malus' law.

OBJECTIVE

Verify Malus' law for linearly polarised light

SUMMARY

Malus' law describes how intensity I of polarised light with an initial intensity I_0 , having passed through an analyser filter, depends on the angle of rotation of the filter. The intensity of the light is measured using a light sensor.

REQUIRED APPARATUS

Quantity	Description	Number
1	Optical Precision Bench D, 50 cm	1002630
4	Optical Rider D, 90/50	1002635
1	Optical Lamp, Halogen	1003188
1	Transformer 12 V, 60 VA (230 V, 50/60 Hz)	1000593 or
	Transformer 12 V, 60 VA (115 V, 50/60 Hz)	1006780
2	Polarisation Filter on Stem	1008668
1	Light Sensor	1000562
1	3B NETlog™ (230 V, 50/60 Hz)	1000540 or
	3B NETlog™ (115 V, 50/60 Hz)	1000539

1

BASIC PRINCIPLES

Light, being a transverse wave, can be polarised, for example by allowing it to pass through a polarising filter. In a linearly polarised light wave, both the electric field E and magnetic field B oscillate in distinct planes. The orientation direction of the electric field oscillation is called the polarisation direction.

In this experiment light passes through two filters termed the polariser and the analyser, which are aligned at an angle of φ to one another. The polariser only allows one linearly polarised component of the light to pass through it. The electric field of this component may be deemed to have an amplitude E_0 . The amplitude of the component after passing through the analyser filter is given by

$$(1) \quad E = E_0 \cdot \cos \varphi$$

This is a measure of the amount of light which can pass through the analyser.

The intensity of the light corresponds to the square of the electric field strength. The intensity of light beyond the analyser is therefore as follows:

$$(2) \quad I = I_0 \cdot \cos^2 \varphi,$$

where I_0 is the intensity of light after passing through the polariser.

Equation (2) is a statement of Malus' law. This will be verified in the experiment by measuring the light intensity using a light sensor. In this experiment, the intensity of light measured for an angle $\varphi = 90^\circ$ should be equal to that of the ambient light. This value should be subtracted from all the other intensity measurements.

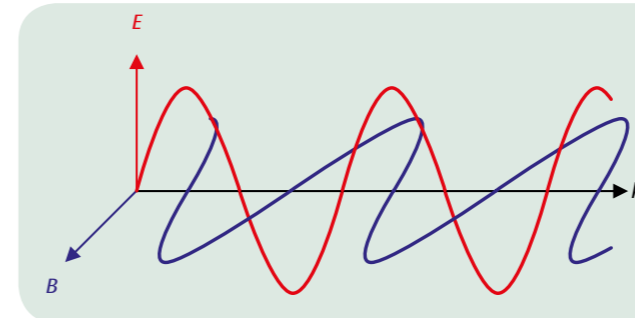

Fig. 1: Illustration showing the definition for direction of polarisation

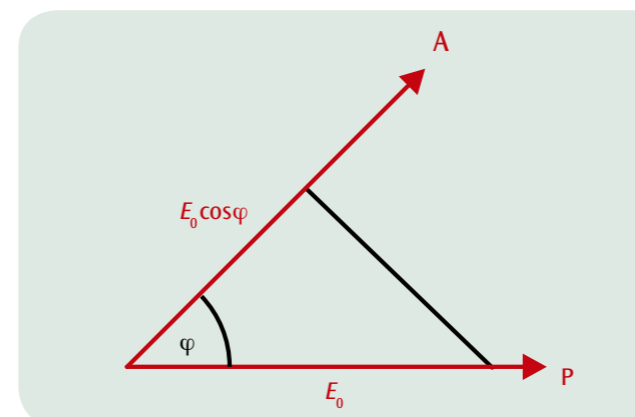

Fig. 2: Illustration of how the electric field beyond the analyser is calculated

EVALUATION

Once the ambient light intensity has been subtracted from all the measurements, they are then plotted as a function of φ . The curve should then be described by equation (2).

Intensity I is then plotted in another graph as a function of $\cos^2 \varphi$. In this case, the measurements lie on a straight line through the origin which has a gradient I_0 .

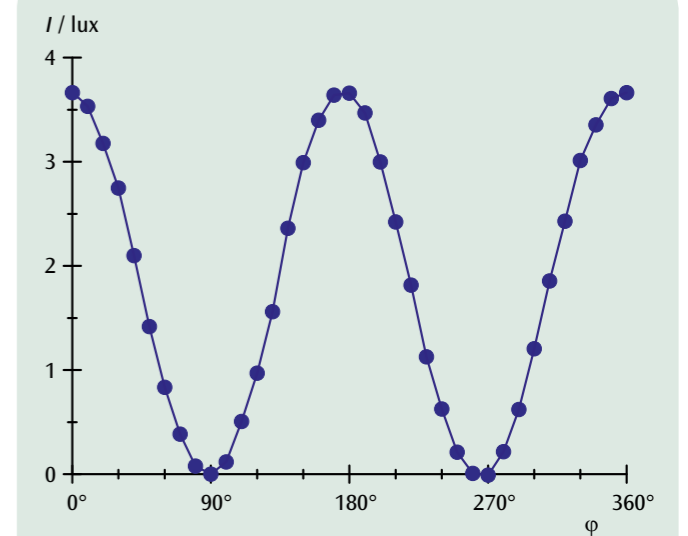

Fig. 3: Light intensity I as a function of the angle φ between the polariser and the analyser

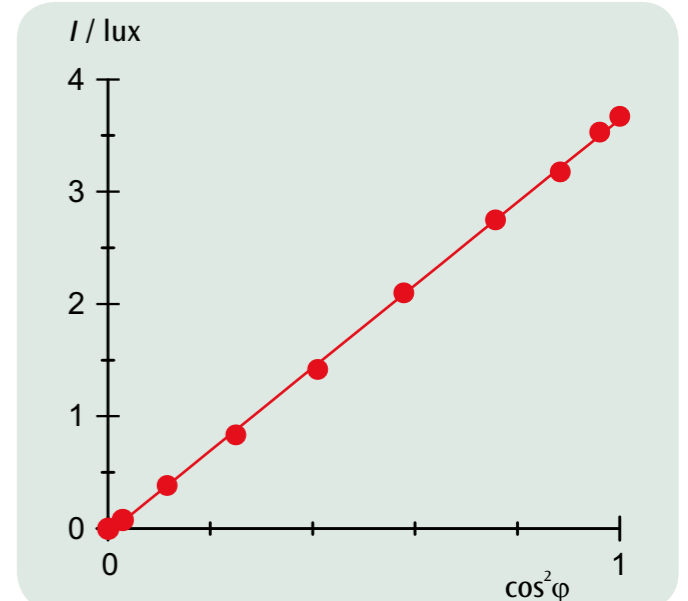

Fig. 4: Light intensity I as a function of $\cos^2 \varphi$



EXPERIMENT PROCEDURE

- Measurement of the angle of rotation as a function of the length of the sample.
- Measurement of the angle of rotation as a function of the solution concentration.
- Determining the specific rotation for different light wavelengths.
- Comparing the directions of rotation and angles of rotation for fructose, glucose and saccharose.
- Measurement of the angle of rotation during the inversion of saccharose to give an equimolar mixture of glucose and fructose.

OBJECTIVE

Investigate the rotation of the plane of polarisation by sugar solutions

SUMMARY

Sugar solutions are optically active, in other words they rotate the plane of polarisation of any linearly polarised light that is passed through them. The direction of rotation depends on the molecular properties of the sugar. Thus, solutions of glucose and saccharose (sucrose) rotate the plane of polarisation to the right (clockwise), whereas fructose solutions rotate it to the left (anti-clockwise), as found when the angle of rotation is measured with a polarimeter. The experiment also includes measuring the angle of rotation to study the behaviour of a saccharose solution when hydrochloric acid is added. This causes a gradual reversal ("inversion") of the direction of rotation from clockwise to anti-clockwise, as the double-ring structure of the saccharose molecule is split into two, giving an equimolar mixture of glucose and fructose. The angle of rotation of the mixture is the sum of the angles of rotation of the dextro-rotatory glucose and the more strongly laevo-rotatory fructose.

REQUIRED APPARATUS

Quantity	Description	Number
1	Polarimeter with 4 LEDs (230 V, 50/60 Hz)	1001057 or
	Polarimeter with 4 LEDs (115 V, 50/60 Hz)	1001056
1	Graduated Cylinder, 100 ml	1002870
1	Beaker	1002872
1	Electronic Scale Scout Pro 200 g (230 V, 50/60 Hz)	1009772 or
	Electronic Scale Scout Pro 200 g (115 V, 50/60 Hz)	1003426

Additionally required:

Fruit Sugar (Fructose), 500 g
Grape Sugar (Glucose), 500 g
Cane Sugar (Sucrose), 500 g

2

BASIC PRINCIPLES

The term **optical activity** is used to describe the rotation of the plane of polarisation of linearly polarised light when it passes through certain substances. This rotation is observed in solutions of chiral molecules such as sugars and in certain solids such as quartz. Substances that rotate the plane of polarisation to the right (i.e., clockwise) as viewed against the direction of propagation of the light are described as **dextro-rotatory**, whereas substances with the opposite behaviour are described as **laevo-rotatory**. Glucose and saccharose solutions are dextro-rotatory, whereas fructose solutions are laevo-rotatory.

The angle α through which the plane of polarisation is rotated by a solution depends on the nature of the dissolved substance, and it is proportional to the concentration (mass per unit volume) c and to the length or thickness d of the sample. The relationship is expressed as:

$$(1) \quad \alpha = [\alpha] \cdot c \cdot d$$

where $[\alpha]$ is called the specific rotation of the dissolved substance. The specific rotation depends on the wavelength λ of the light and the sample temperature T , and the relationship has the form:

$$(2) \quad [\alpha] = \frac{k(T)}{\lambda^2}$$

Values of $[\alpha]$ in published tables are usually given for yellow sodium light at an ambient temperature of 25°C. If $[\alpha]$ is known, the concentration of a solution can be determined by measuring the angle of rotation in a polarimeter.

In the experiment, measurements are made on solutions of different sugars in a polarimeter under different conditions, and the angles of rotation are compared. The colour of the light can be changed by choosing between four LEDs. The effect of adding hydrochloric acid to a solution of ordinary cane sugar (saccharose) is also investigated. This causes a slow reaction whereby the double-ring structure is split to give an equimolar mixture of glucose and fructose. During this process the direction of rotation becomes "inverted" from clockwise to anti-clockwise, because the angle of rotation after completion of the reaction is the sum of the angles of rotation of the dextro-rotatory glucose and the more strongly laevo-rotatory fructose.

EVALUATION

According to Equation (1), the angle of rotation of a solution of a given substance at a fixed concentration is proportional to the length of the sample, whereas for a fixed sample length it is proportional to the concentration. From the gradients of the straight lines through the origin in Figure 1, the specific rotation for each of the four wavelengths provided by the polarimeter can be calculated.

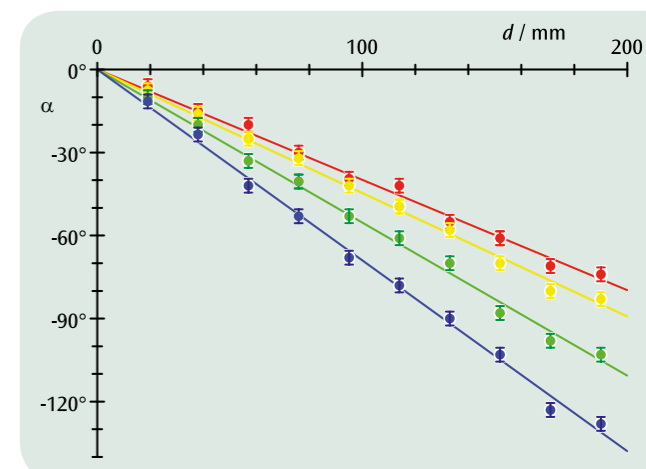

Fig. 1: Angle of rotation of a fructose solution ($c = 0.5 \text{ g/cm}^3$) as a function of sample length for four different light wavelengths

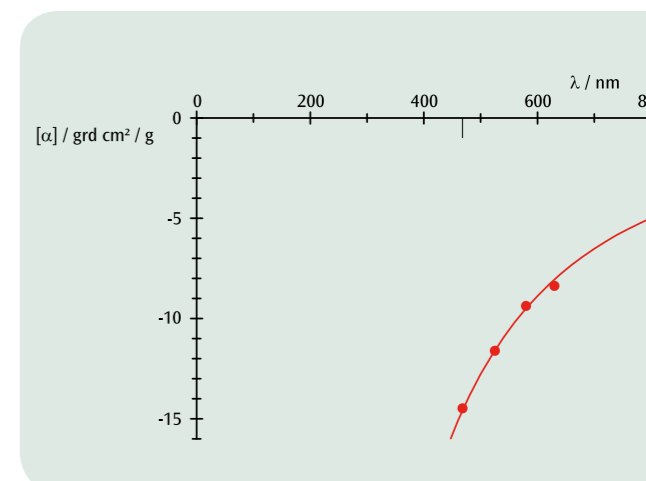

Fig. 2: Dependence of specific rotation on wavelength

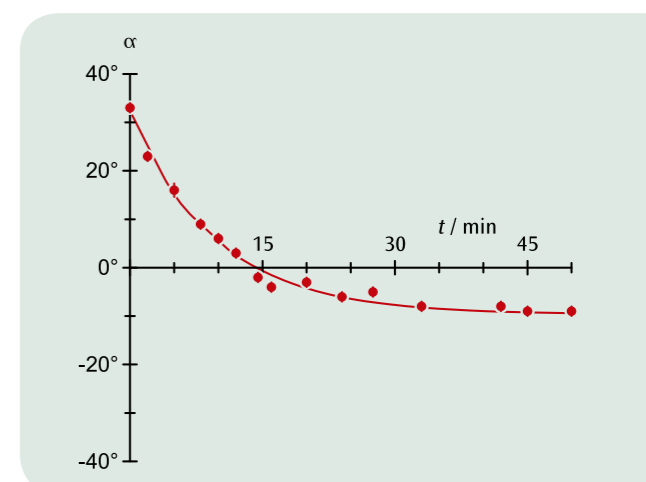
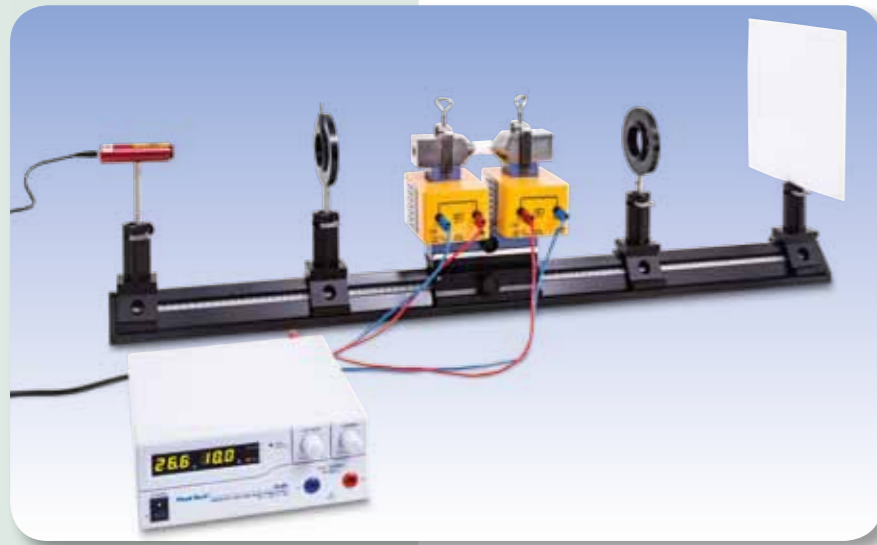

Fig. 3: Angle of rotation of a saccharose solution ($c = 0.3 \text{ g/cm}^3$, $d = 190 \text{ mm}$) during the inversion process as a function of time



EXPERIMENT PROCEDURE

- Demonstrate the Faraday effect in flint glass.
- Measure the angle of rotation of the polarisation plane in the magnetic field.
- Determine the Verdet constant for red and green light.
- Determine the Cauchy coefficient b for the refractive index.

OBJECTIVE

Demonstrate the Faraday effect and determine the Verdet constant for flint glass

SUMMARY

Optically isotropic, transparent, non-magnetic materials become optically active in a magnetic field. They rotate the plane of polarisation of linearly polarised light passing through them in the direction of the magnetic field because clockwise and anti-clockwise circularly polarised components of the light take differing amounts of time to pass through. This effect is known as the Faraday effect. In this experiment, the Faraday effect will be measured for flint glass. This particular type of glass exhibits a high degree of very uniform optical dispersion. The way that the frequency depends on the refractive index n is given to a good approximation by a Cauchy formula.

REQUIRED APPARATUS

Quantity	Description	Number
1	Optical Precision Bench D, 100 cm	1002628
4	Optical Rider D, 90/50	1002635
1	Optical Base D	1009733
1	Laser Diode, Red	1003201
1	Laser Module, Green	1003202
2	Polarisation Filter on Stem	1008668
1	Projection Screen	1000608
1	Transformer Core D	1000976
2	Pair of Pole Shoes	1000978
2	Coil D, 900 Turns	1012859
1	Flint Glass Block for Faraday Effect	1012860
1	Accessories for Faraday Effect	1012861
1	Teslameter E	1008537
1	Magnetic Field Sensor, Axial/Tangential	1001040
1	Barrel Foot, 1000 g	1002834
1	Universal Jaw Clamp	1002833
1	Set of 15 Experiment Leads, 75 cm 1 mm ²	1002840
1	DC Power Supply, 1 – 32 V, 0 – 20 A (230 V, 50/60 Hz)	1012857 or
	DC Power Supply, 1 – 32 V, 0 – 20 A (115 V, 50/60 Hz)	1012858

2

BASIC PRINCIPLES

Optically isotropic, transparent, non-magnetic materials become optically active in a magnetic field. They rotate the plane of polarisation of linearly polarised light passing through them in the direction of the magnetic field because clockwise and anti-clockwise circularly polarised components of the light take differing amounts of time to pass through. This effect is known as the Faraday effect.

The difference in the time it takes the polarised light to pass can be explained in terms of the change in frequency experienced by the polarised light in the magnetic field using a simple model. Light with a clockwise polarisation undergoes a slight increase in frequency f by an amount called the Larmor frequency

$$(1) \quad f_l = \frac{e}{4\pi \cdot m_e} \cdot B$$

$e = 1.6021 \cdot 10^{-19}$ As: Charge of an electron

$m_e = 9.1 \cdot 10^{-31}$ kg: Rest mass of an electron

The frequency of anti-clockwise polarised light decreases by the same amount, i.e.

$$(2) \quad f_z = f \pm f_l$$

The differing frequencies can be attributed to differing refractive indices in the material. This means that the speed of propagation of waves inside the material differs as well.

These statements make it possible to determine the rotation of the plane of polarisation in optically active materials, as follows:

$$(3) \quad \varphi = 2\pi \cdot f \cdot (t_+ - t_-) = 2\pi \cdot f \cdot \frac{d}{c} \cdot (n(f_+) - n(f_-))$$

d : Length of sample,

$c = 2,998 \cdot 10^8 \frac{\text{m}}{\text{s}}$: Speed of light

Since the Larmor frequency f_l is much smaller than f , it follows that:

$$(4) \quad \begin{aligned} \varphi &= 2\pi \cdot f \cdot \frac{d}{c} \cdot \frac{dn}{df} \cdot 2 \cdot f_l \\ &= f \cdot \frac{dn}{df} \cdot \frac{e}{m_e \cdot c} \cdot B \cdot d \end{aligned}$$

The angle of rotation φ is also proportional to the magnetic field B and the length of material d through which the light passes:

$$(5) \quad \varphi = V \cdot B \cdot d$$

The constant of proportionality

$$(6) \quad V = \frac{e}{m_e \cdot c} \cdot f \cdot \frac{dn}{df}$$

is called the Verdet constant and is dependent on the dispersion of the light in the material through which it passes and on the frequency f of that light. In this experiment, measurements are made of the Faraday effect in flint glass (F2). This particular type of glass exhibits a high degree of very uniform optical dispersion. The way that the frequency depends on the refractive index n is given to a good approximation by a Cauchy formula.

$$(7) \quad \begin{aligned} n(f) &= a + \frac{b}{c^2} \cdot f^2 \\ \text{where } a &= 1.62, b = 8920 \text{ nm}^2 \end{aligned}$$

To improve the accuracy of the measurement for small angles of rotation, this experiment is set up in such a way that when the magnetic field B is positive the polarisation of the light is such that the analyser filter causes the transmitted light to go dark at precisely 0° . When the magnetic field is switched to a negative one $-B$, the analyser must be rotated by an angle 2φ in order to shut out the light again.

EVALUATION

From equations (6) and (7), the following can be derived:

$$V = \frac{2 \cdot e \cdot b \cdot f^2}{m_e \cdot c^3} = \frac{2 \cdot e \cdot b}{m_e \cdot c \cdot \lambda^2}$$

This means that it is possible to obtain the Cauchy coefficient b for the refractive index of the flint glass used here from the Verdet constant, as long as the wavelength λ of the light is known.

$$b = \frac{m_e \cdot c}{2 \cdot e} \cdot V \cdot \lambda^2$$

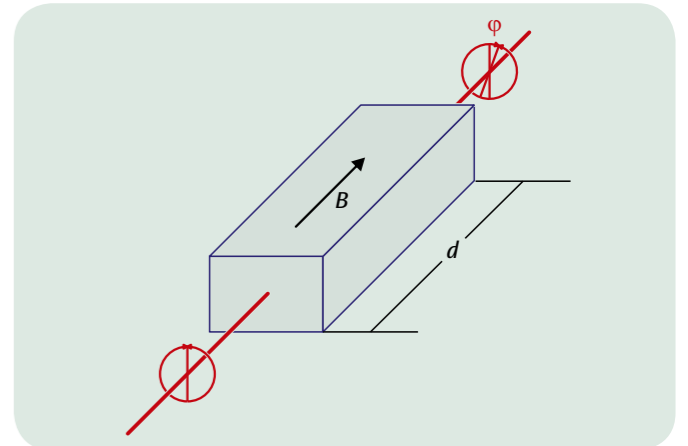

Fig. 1: Schematic diagram to illustrate the Faraday effect

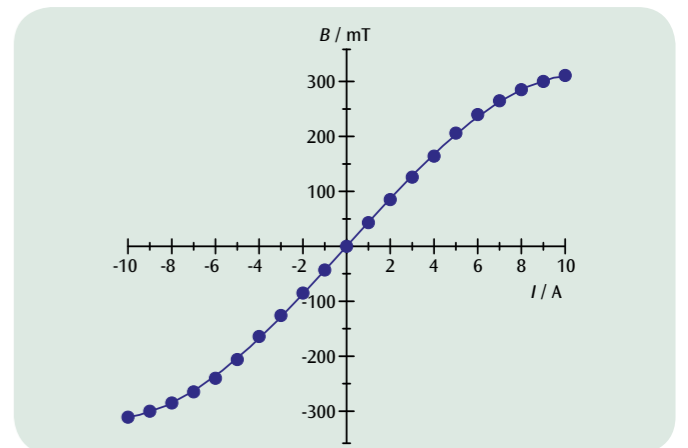

Fig. 2: Calibration curve for electromagnet

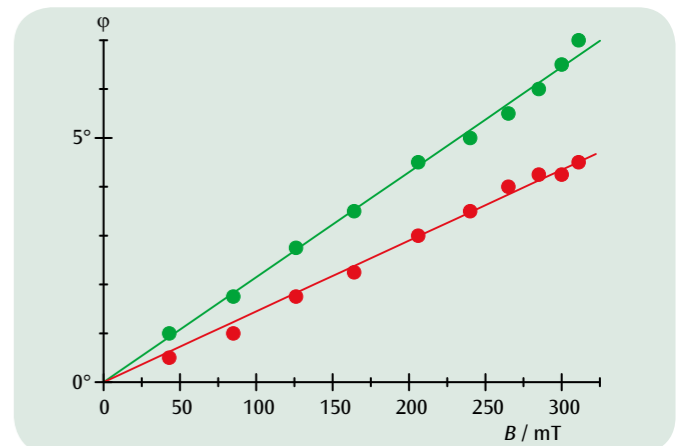

Fig. 3: Angle of rotation as a function of the magnetic field for red and green laser light



EXPERIMENT PROCEDURE

- Calibrate an offset to compensate for ambient light.
- Measure the relative light intensity as a function of the distance.
- Plot a graph of S against $1/r^2$.

OBJECTIVE

Verify the inverse square law for the intensity of radiation from a source of light

SUMMARY

According to the inverse square law, the intensity of radiation from a light source, i.e. the power per unit area, is inversely proportional to the square of the distance from the source. This will be investigated in an experiment using an incandescent light bulb. When the distance from the lamp is much greater than the size of the filament, such a bulb can be regarded as a point source of light. In order to measure the relative intensity of the radiation, a Moll thermopile is used.

REQUIRED APPARATUS

Quantity	Description	Number
1	Stefan Boltzmann lamp	1008523
1	Moll-Type Thermopile	1000824
1	Measurement Amplifier (230 V, 50/60 Hz)	1001022 or
	Measurement Amplifier (115 V, 50/60 Hz)	1001021
1	DC Power Supply 0 – 20 V, 0 – 5 A (230 V, 50/60 Hz)	1003312 or
	DC Power Supply 0 – 20 V, 0 – 5 A (115 V, 50/60 Hz)	1003311
1	Digital Multimeter P1035	1002781
1	HF Patch Cord, BNC/4 mm Plug	1002748
1	Ruler, 1 m	1000742
2	Barrel Foot, 500 g	1001046
1	Set of 15 Safety Experiment Leads, 75 cm	1002843

1

BASIC PRINCIPLES

The inverse square law describes a fundamental relationship which applies, among other things, to the intensity of light. The intensity of the light, i.e. the power detected within a unit area is inversely proportional to the square of the distance from the light source.

For this law to apply, the source needs to be radiating light uniformly in all directions and its dimensions must be negligible in comparison to its distance from the detector. In addition, there must be no absorption or reflection of light between the source and the point where the measurement is being made.

Since the source radiates uniformly on all directions, the emitted power P is distributed across the surface of a sphere at a distance r from the source.

$$(1) \quad A = 4\pi \cdot r^2$$

The light intensity is therefore given by the following

$$(2) \quad S = \frac{dP}{dA} = \frac{P}{4\pi \cdot r^2}$$

Equation (2) will be verified in this experiment using an incandescent bulb. When the distance from the lamp is much greater than the size of the filament, such a bulb can be regarded as a point source of light. In order to measure the relative intensity of the radiation, a Moll thermopile is used. Instead of the absolute intensity S , the thermopile voltage U_{th} is read off as a measure of the relative intensity.

EVALUATION

While making these measurements, it is unavoidable that the intensity of the ambient light will be detected as well as that from the source. For this reason, an offset is calibrated on the microvoltmeter before the actual measurements are made. To check the calibration, a general straight line is drawn through the measured points.

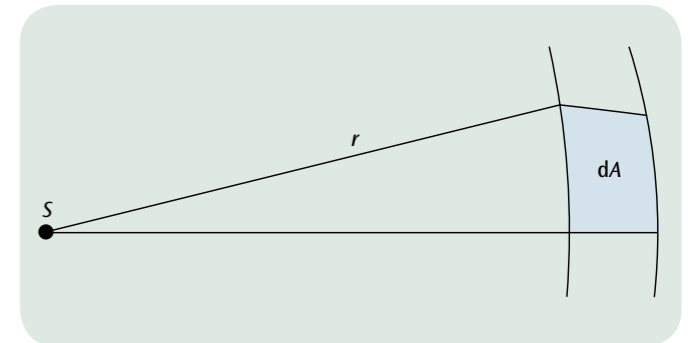

Fig. 1: Square of distance

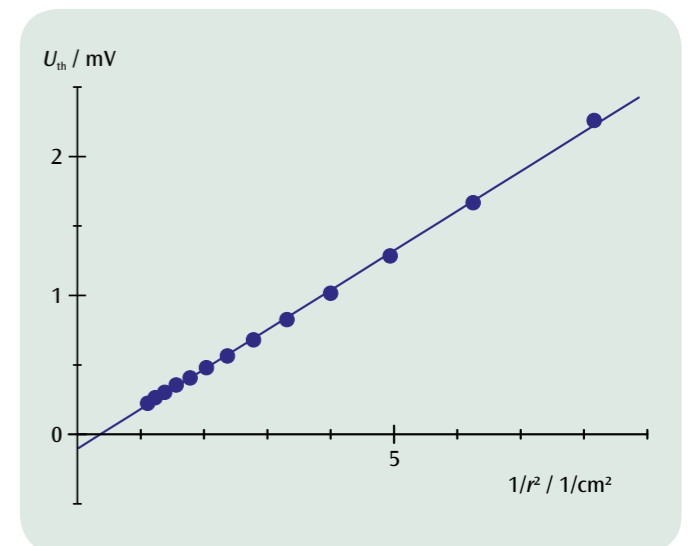

Fig. 2: Measurements plotted in a graph of U_{th} against $1/r^2$



EXPERIMENT PROCEDURE

- Make a relative measurement of the intensity of radiation from an incandescent lamp with a tungsten filament as a function of temperature with the help of a Moll thermopile.
- Measure the resistance of the filament in order to determine the filament's temperature.
- Plot the measurements in a graph of $\ln(U_{th})$ against $\ln(T)$ and determine the exponent from the slope of the resulting straight line.

OBJECTIVE

Verify that intensity of radiation is proportional to the fourth power of the temperature, T^4

SUMMARY

The way that intensity of radiation from a black body depends on temperature is described by the Stefan-Boltzmann law. Similar dependence on temperature is exhibited by the intensity of radiation from an incandescent lamp with a tungsten filament. In this experiment, a Moll thermopile is used to make a relative measurement which verifies the law. The temperature of the filament can be determined from the way its resistance depends on temperature, which can be determined very accurately using a four-wire method.

REQUIRED APPARATUS

Quantity	Description	Number
1	Stefan Boltzmann lamp	1008523
1	DC Power Supply 0 – 20 V, 0 – 5 A (230 V, 50/60 Hz)	1003312 or
	DC Power Supply 0 – 20 V, 0 – 5 A (115 V, 50/60 Hz)	1003311
1	Moll-Type Thermopile	1000824
3	Digital Multimeter P1035	1002781
2	Barrel Foot, 1000 g	1002834
1	Set of 15 Safety Experiment Leads, 75 cm	1002843

2

BASIC PRINCIPLES

Both the total intensity and the spectral distribution of the heat radiation from a body are dependent on the body's temperature and the nature of its surface. At a specific wavelength and temperature, the body emits more radiation if it is also better able to absorb it. A black body, a body with ideal surface characteristics, fully absorbs radiation of all wavelengths and can therefore emit the greatest amount of thermal radiation for a given temperature. Such a body is assumed when investigating how radiation of heat depends on temperature.

The way that intensity of radiation S from a black body depends on temperature is described by the Stefan-Boltzmann law.

$$(1) \quad S_0 = \sigma \cdot T^4$$

T : absolute temperature

$$\sigma = 5,67 \cdot 10^{-8} \frac{\text{W}}{\text{m}^2 \text{K}^4} : \text{Stefan-Boltzmann constant}$$

It is not possible to determine this intensity directly, since the body will also simultaneously be absorbing radiation from its surroundings. The intensity as measured is therefore

$$(2) \quad S_1 = \sigma \cdot (T^4 - T_0^4)$$

T_0 : absolute temperature of surroundings

Light emitted from an incandescent lamp also counts as heat radiation. In this case, the temperature of the filament is determined in such a way that a large amount of the heat is emitted in the spectrum of visible light. The way the total intensity of radiation depends on temperature is equivalent to that of a black body:

$$(3) \quad S = \varepsilon \cdot \sigma \cdot (T^4 - T_0^4)$$

This is because the filament absorbs a proportion ε of radiation of all frequencies.

An incandescent lamp of this kind with a tungsten filament will be investigated in this experiment in order to determine how the intensity of radiation depends on the temperature. A Moll thermopile is used to measure relative radiation intensity. The temperature of the filament can be determined using the temperature-dependency of its resistance:

$$(4) \quad R = R_0 (1 + \alpha \cdot (T - T_0))$$

R_0 : resistance at ambient temperature T_0

$$\alpha = 4,4 \cdot 10^{-3} \frac{1}{\text{K}} \text{ for tungsten}$$

R can be determined very accurately using a four-wire measurement.

EVALUATION

The following expression for temperature T is derived from equation (4)

$$T = \frac{R - R_0}{\alpha \cdot R_0} + T_0$$

However, equation (4) only applies as a good approximation. For more accurate results, it is possible to use a table provided in the operating instructions for the Stefan-Boltzmann lamp.

In this experiment, temperatures T are chosen to be so high that the ambient temperature T_0 can be ignored in equation (3). Instead of the absolute intensity S , the thermopile voltage U_{th} is read off as a measure of relative intensity. Equation (3) can then be rewritten as

$$U_{th} = a \cdot T^4 \text{ or } \ln(U_{th}) = \ln(a) + 4 \cdot \ln(T)$$

This means that a graph of $\ln(U_{th})$ against $\ln(T)$ will show all the measurement points along a straight line of gradient 4.

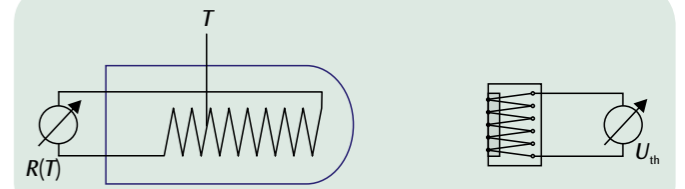

Fig. 1: Schematic of set-up

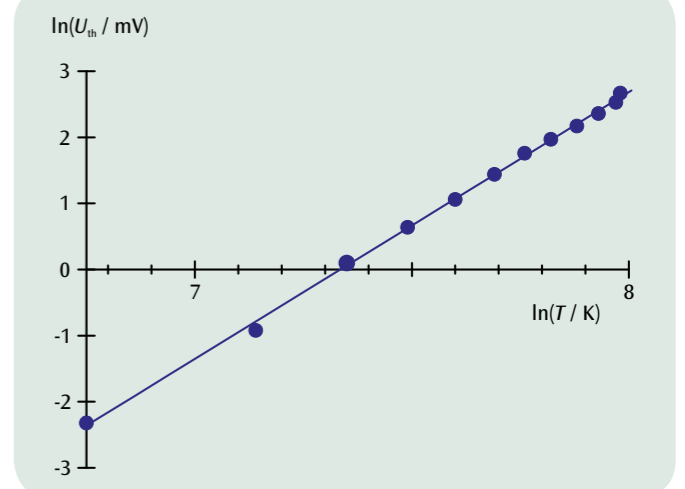

Fig. 2: Graph of $\ln(U_{th})$ against $\ln(T)$



EXPERIMENT PROCEDURE

- Measuring the transit time of a short pulse of light across a known distance, by using an oscilloscope to compare it with a reference signal.
- Determining the velocity of light in air as a quotient of the distance travelled and the transit time.

OBJECTIVE

Determine the velocity of light from the transit time of short light pulses

SUMMARY

The fact that light is propagated at a finite speed can be demonstrated by a simple transit time measurement. This is achieved by using very short light pulses of only a few nanoseconds duration and determining the time for them to travel out and back over a distance of several metres, which is measured by an oscilloscope. From the transit time and the distance from the transmitter to a triple-prism reflector one can calculate the velocity of light.

REQUIRED APPARATUS

Quantity	Description	Number
1	Speed of Light Meter (115 V, 50/60 Hz)	1000882 or
	Speed of Light Meter (230 V, 50/60 Hz)	1000881
1	Analogue Oscilloscope 2x150 MHz	1002729
1	Optical Bench U, 600 mm	1003040
2	Optical Rider U, 75 mm	1003041
1	Barrel Foot	1001045
1	Stainless Steel Rod 1500 mm	1002937
1	Universal Clamp	1002830
1	Pocket Measuring Tape, 2 m	1002603

1

BASIC PRINCIPLES

The fact that light is propagated at a finite speed can be demonstrated by a simple transit time measurement using modern measurement techniques. This is achieved by using very short light pulses of only a few nanoseconds duration and determining the time for them to travel out and back over a distance of several metres, which is measured by an oscilloscope.

In the experiment, the short light pulses from a pulsed LED are passed via a beam-splitter onto two photoelectric cells whose amplified signals are recorded as voltage pulses by the oscilloscope. Photocell A receives light pulses reflected back by a triple-prism reflector at a large distance, whereas photocell B records the locally generated light pulse as a reference pulse that is not delayed by transit. The oscilloscope trace is triggered by a voltage pulse from output C, which precedes the reference pulse by 60 ns.

Using a two-channel oscilloscope, one measures the transit time as the difference t between the two pulses. From this and the distance s from the transmitter to the triple-prism reflector, we can calculate the velocity of light as:

$$(1) \quad c = \frac{2 \cdot s}{t}$$

The experiment can be made more impressive by varying the distance to the reflector and observing the resulting change of the pulse separation on the oscilloscope. This can be done very easily, as careful and precise adjustments in repositioning the triple-prism reflector are not required, rather, an approximate adjustment will suffice.

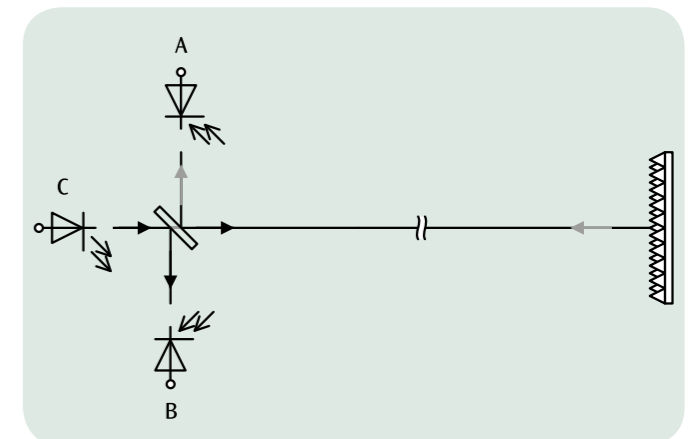

Fig. 1: Measurement principle

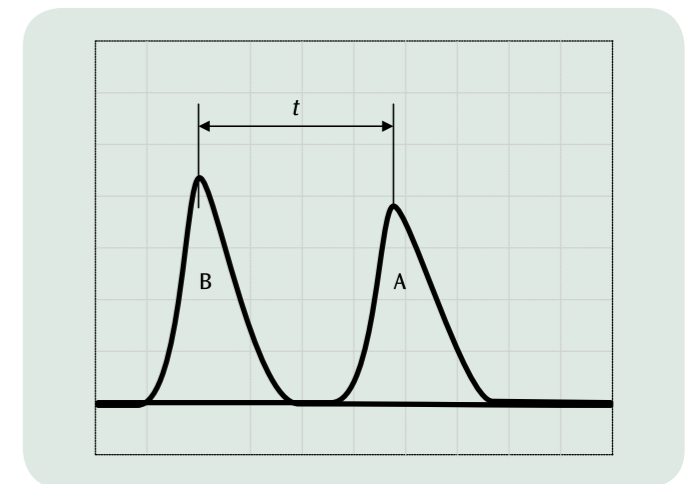
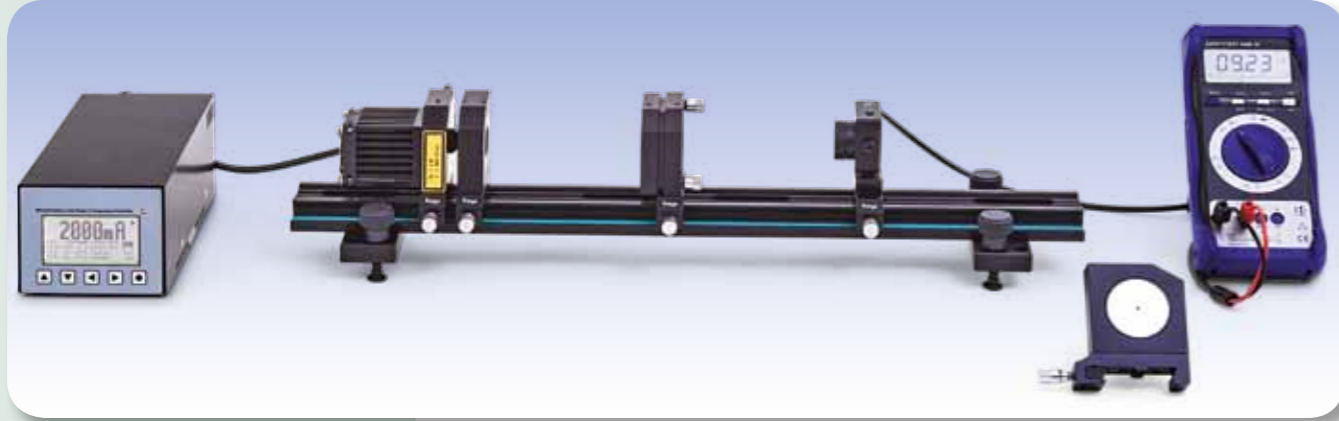

Fig. 2: Measuring the transit time with the oscilloscope



EXPERIMENT PROCEDURE

- Calibrate the diode laser for stable optical pumping of the Nd:YAG laser.
- Determine the lifetime of the top laser energy level ${}^4F_{3/2}$ in the Nd:YAG crystal
- Adjust the resonator and observe the resonator modes.
- Measure the output power of the Nd:YAG laser as a function of the pumping power and determine the lasing threshold.
- Observing spiking when the laser diode is being operated in pulsed mode.

WARNING

This experiment uses a class 4 laser set-up emitting in the non-visible (infra-red) spectrum. For this reason, goggles for protection against laser light must be worn at all times. Do not look directly into the laser beam even while wearing protective goggles.

3

OBJECTIVE

Set up and optimise an Nd:YAG laser

SUMMARY

In this experiment an Nd:YAG laser with a diode laser pump is to be set up and optimised. Once the diode laser is calibrated for stable optical pumping and the resonator has been optimised, the system can then be used as an Nd:YAG laser. An investigation is to be made of both steady-state and non-steady-state operation and the lifetime of the top laser energy level ${}^4F_{3/2}$ in the Nd:YAG crystal will then be determined.

REQUIRED APPARATUS

Quantity	Description	Number
1	Laser Diode Driver and Two-Way Temperature Controller Dsc01-2.5	1008632
1	Optical Bench KL	1008642
1	Diode Laser 1000 mW	1009497
1	Nd:YAG Cristal	1008635
1	Collimator lens $f = +75$ mm	1008646
1	Laser Mirror I	1008638
1	PIN Photodiode	1008640
1	Filter RG850	1008648
1	Alignment Laser Diode	1008634
1	Transport Case KL	1008651
1	Laser Safety Goggles for Nd:YAG Laser	1002866
1	Digital Multimeter P3340	1002785
1	Digital Oscilloscope 4x60 MHz	1008676
1	HF Patch Cord, BNC/4 mm Plug	1002748
1	HF Patch Cord	1002746
1	IR Detector Card	1017879

BASIC PRINCIPLES

An Nd:YAG laser is a solid-state laser which emits an infra-red beam. The laser medium is a neodymium-doped yttrium-aluminium garnet crystal. Pumping is handled by a semiconductor laser. Usually the light emitted has a wavelength of 1064 nm.

Fig. 1 shows the energy levels for an Nd:YAG crystals with the most important transitions for optical pumping and laser operation. By means of optical pumping using light with an approximate wave-

length of 808 nm, transitions can be excited between the ground state (1) and the top pumping level (4). Its lifetime is very short and rapid, non-radiating transitions take place into the upper metastable excited laser level (3). This prevents transitions occurring back into the ground state. The lasing transition of wavelength $\lambda = 1064$ nm takes place into the lower excited laser level (2). This has a very short lifetime and decays without emission into the ground state. This means that each of the levels is occupied to a certain extent. States 4 and 2, however, decay so quickly that the number of atoms in each of these states can be assumed to be close to zero. This means that the dynamic response of the laser can be described using the following rate equations for inversion density n (the difference in the number density of atoms in Nd energy levels 2 and 3) and photon density p of the laser field:

$$(1a) \quad \frac{dn}{dt} = W \cdot (N_{Nd} - n) - \sigma \cdot c \cdot p \cdot n - \frac{n}{\tau_3}$$

$$(1b) \quad \frac{dp}{dt} = \frac{L_{Nd}}{L} \cdot \sigma \cdot c \cdot p \cdot n - \frac{p}{\tau_{res}}$$

W : pumping rate

N_{Nd} : number density of Nd atoms

σ : effective cross section for emission or absorption of a photon

c : speed of light

τ_3 : lifetime of excited laser level 3

L : length of resonator

L_{Nd} : length of Nd:YAG crystal

τ_{res} : time constant for resonator losses

In (1a) the first term relates to the optical pumping, the second refers to the induced emission and the third covers the decay from the top laser level via spontaneous emission. The first term in (1b) concerns creation of a photon by induced emission, while the second describes the fall in the photon density due to losses in the resonator. For greater accuracy, it is also necessary to take into account that photons are already present at the start of the process due to spontaneous emission.

For steady-state operation and disregarding spontaneous emission, the following solution is obtained:

$$(2) \quad p = \frac{1}{\sigma \cdot c \cdot \tau_3} \cdot \frac{W - W_s}{W_s}$$

where

$$W_s = \frac{1}{\tau_3} \cdot \frac{n_i}{n_i - N_{Nd}} \quad n_i = \frac{L}{L_{Nd} \cdot \sigma \cdot c \cdot \tau_{res}}$$

The pumping rate therefore needs to exceed a certain threshold, after which the photon density rises linearly in proportion to the pumping rate. It is not possible to measure the photon density and pumping rate directly. Therefore the experiment will demonstrate that the output power of the laser PL is linearly dependent on the pumping power above a certain threshold. Fig. 2 shows solutions of the rate equations for non-steady-state operation. In this case there is an initial rise in the photon population inversion. Once the threshold inversion n_i has been reached, the inversion density increases linearly. There is a rapid rise in photon density and the inversion density falls to a value slightly below the threshold. As this process is repeated, the overshoot of the inversion density gradually decreases until the system settles into the steady state. The experiment will also demonstrate this so-called spiking.

First, though, the wavelength of the diode laser used for the pumping is calibrated to the transition where $\lambda = 808$ nm and then the change in the

spontaneous emission over time is measured with the diode laser operating in pulsed mode (Fig. 3). From these measurements it is possible to determine the lifetime of the upper laser level. Once the resonator is set up and calibrated, spiking may be observed (Fig. 4). Finally the output power is measured as a function of the pumping power.

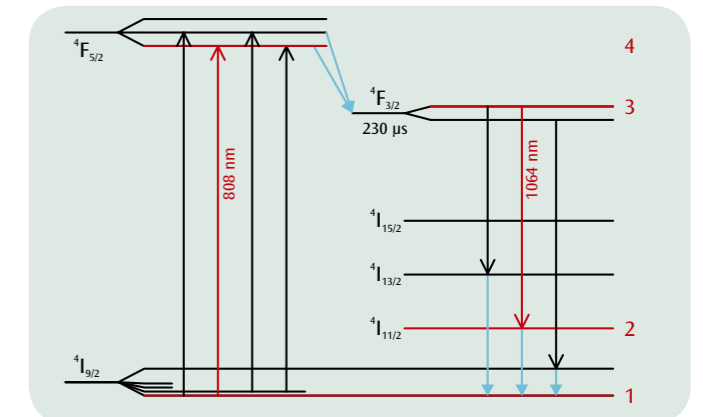

Fig. 1: Energy level diagram for Nd:YAG crystal. The transitions which are relevant to this experiment are indicated in red

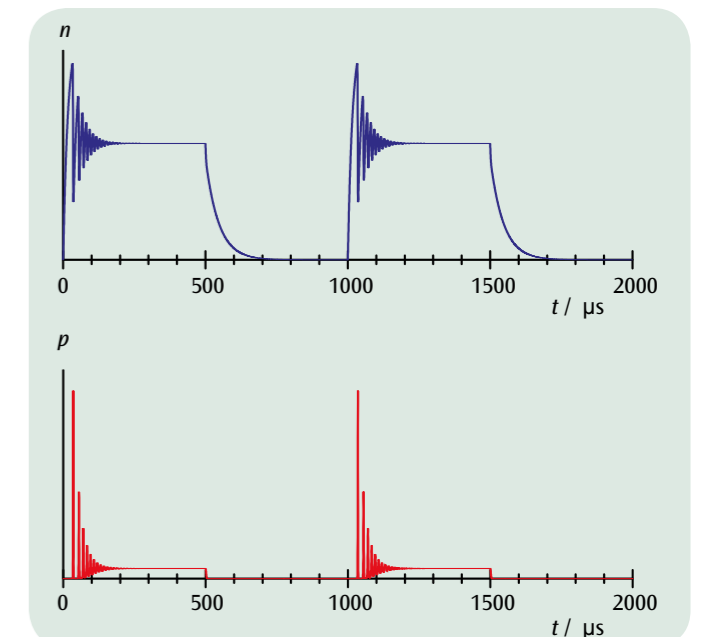

Fig. 2: Non-static solutions of the rate equations (spiking)

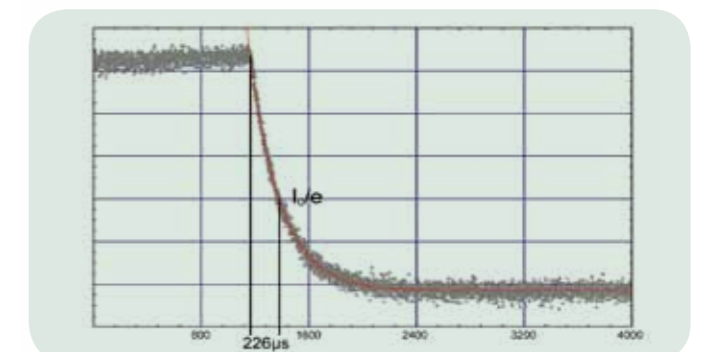
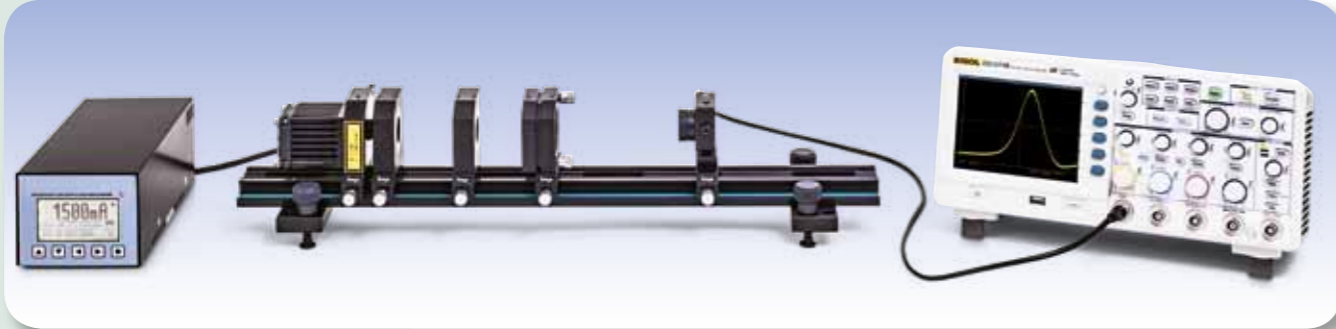

Fig. 3: Measurement of spontaneous emission in order to determine the lifetime of the upper laser level



EXPERIMENT PROCEDURE

- Set up and optimise a Q-switching circuit for an Nd:YAG lasers using a Cr:YAG module.
- Record the pulses and determine their duration.

OBJECTIVE

Q-switching circuit for Nd:YAG laser with Cr:YAG module

SUMMARY

Q-switching of a laser makes it possible to generate short, high-energy pulses. It works by controlling the laser threshold by increasing or decreasing resonator losses. You are to implement a passive Q-switching circuit with the help of a Cr:YAG module and then record the laser pulsing over time. The energy of the pulses can be calculated from the average power and the frequency with which they are repeated

REQUIRED APPARATUS

Quantity	Description	Number
1	Laser Diode Driver and Two-Way Temperature Controller Dsc01-2.5	1008632
1	Optical Bench KL	1008642
1	Diode Laser 1000 mW	1009497
1	Nd:YAG Cristal	1008635
1	Passive Q-Switch	1008637
1	Laser Mirror I	1008638
1	PIN Photodiode, Fast	1008641
1	Filter RG850	1008648
1	Alignment Laser Diode	1008634
1	Transport Case KL	1008651
1	Laser Safety Goggles for Nd:YAG Laser	1002866
1	Digital Multimeter P3340	1002785
1	Digital Oscilloscope 4x60 MHz	1008676
1	HF Patch Cord, BNC/4 mm Plug	1002748
1	HF Patch Cord	1002746
1	IR Detector Card	1017879

3

WARNING

This experiment involves operation of class-4 laser equipment which emits light in the (invisible) infra-red part of the spectrum. Goggles which protect against laser light should always be worn. Even when wearing such goggles, never look at the laser beam directly.

BASIC PRINCIPLES

Q-switching (also called giant pulse formation) makes it possible to generate short, high-energy laser pulses, as required in the processing of materials, for example. It works by controlling the laser threshold by increasing or decreasing resonator losses. When losses are high, it prevents the build-up of oscillation in the resonator and causes pumping energy to be stored in the laser crystal. Once the resonator is enabled by reducing the losses, a laser pulse of intensity orders of magnitude greater than the intensity in continuous mode is generated. The difference between this and spiking is that the inversion density with Q-switching far exceeds the threshold value. A distinction is made between active and passive Q-switching. Passive Q-switches are absorbers in which the capacity to absorb can be modified by means of the light in the resonator. Active switches are typically acousto-optic, electro-optic or mechanical switches, which control the transmission externally.

Use of an absorbing crystal as a passive Q-switch requires that the absorption can be saturated. That means that its effective absorption cross section must be larger than that for the light from atoms in an excited state, also that the lifetime of the excited level is both longer than the duration of the laser pulse and shorter than the frequency of repetition. A Cr:YAG crystal fulfils all these criteria.

In order to fully describe the dynamic response of the passively Q-switched laser, the rate equation for the inversion density n achievable by means of optical pumping in an Nd:YAG crystal for a photon density p in the field of the laser light (see experiment UE4070310) also needs to take into account the population density in the ground state of the Cr:YAG crystal. Due to the extremely rapid increase of the photon density, both the pumping rate and the rate of spontaneous emission can be disregarded. The threshold for the inversion density is defined as follows:

$$(1) \quad n_s = \frac{1}{\sigma \cdot c \cdot \tau_{res}}$$

τ_{res} : time constant for reduction in photon density due to resonator losses
 σ : effective cross section for emission or absorption of a photon
 c : speed of light

This implies that the change in inversion density n and in the photon density p over time is given by:

$$(2a) \quad \frac{dn}{dt} = -\frac{n}{n_s} \cdot \frac{p}{\tau_{res}}$$

and

$$(2b) \quad \frac{dp}{dt} = -\left(\frac{n}{n_s} - 1\right) \cdot \frac{p}{\tau_{res}}$$

In a giant pulse, the inversion density is approximately constant and remains almost equal to the initial inversion density:

$$(3) \quad n(t) = n_i$$

Equation (2b) can then be used to determine the photon density:

$$(4) \quad p(t) = \exp\left[\left(\frac{n_i}{n_s} - 1\right) \cdot \frac{t}{\tau_{res}}\right]$$

The inversion density n_i for a giant pulse is very much greater than the threshold inversion density n_s . That means that the time it takes for the photon density to increase is much shorter than the time constant τ_{res} for resonator losses.

Another key point in time is reached when the inversion density falls back to the threshold level. Then the photon density ceases to change as described in equation (2b), i.e. no more laser photons are generated. Equation (2a) then gives us:

$$(5) \quad \frac{dn}{dt} = -\frac{p_{max}}{\tau_{res}} \quad \text{where } p(t) = p_{max}$$

The photon density therefore falls after reaching its maximum with a time constant equal to that for the resonator losses.

The maximum value for the photon density is given by the following:

$$(6) \quad p_{max} = n_s \cdot \ln\left(\frac{n_s}{n_i}\right) - (n_s - n_i)$$

This means that lasers with an upper laser level that has a very short lifetime, i.e. which only have a very small excess inversion density, do not exhibit any significant increase in output power when used in pulsed mode. In this experiment the Cr:YAG module is added to the resonator and fine adjustment of the laser is carried out anew. The laser signal is measured using a PIN diode and traced on an oscilloscope.

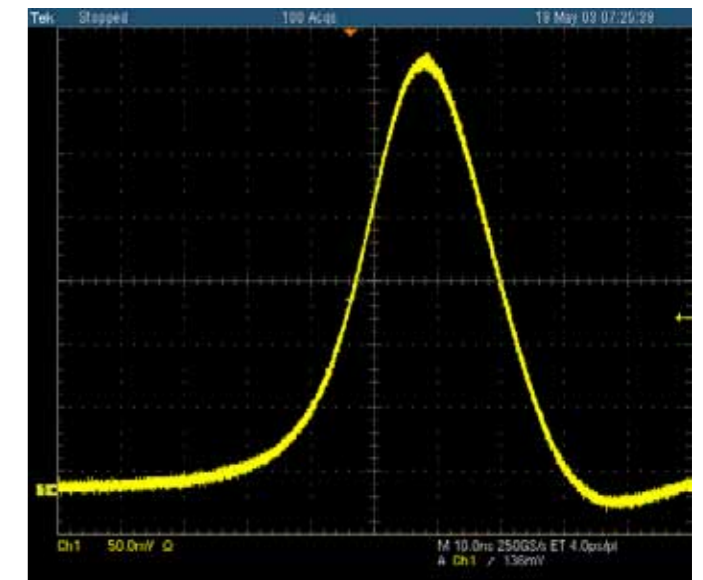
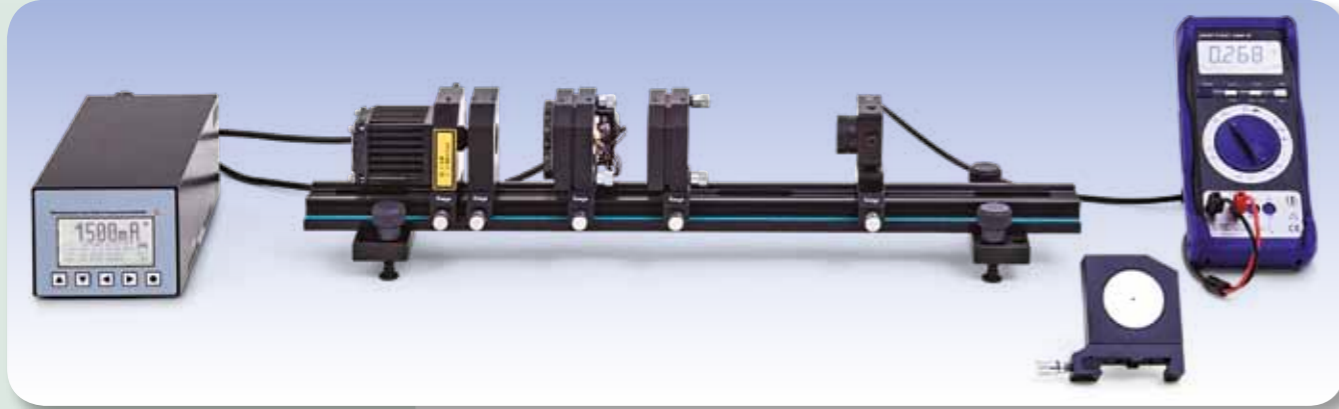

Fig. 1: Pulse over a period of time for an Nd:YAG laser with passive Q-switching



EXPERIMENT PROCEDURE

- Generate radiation at double the original frequency by adding a KTP crystal to the resonator.
- Measure the output power of the radiation at the doubled frequency as a function of the power associated with the fundamental wave.
- Study how the generated radiation depends on the alignment of the crystal and the temperature.

OBJECTIVE

Frequency doubling inside the resonator of a Nd:YAG laser

SUMMARY

Materials often change their optical properties in strong electromagnetic fields. For instance, it is possible for the frequency of high-intensity laser light passing through such materials to be doubled. In this experiment, a KTP (potassium titanyl phosphate) crystal is used to generate green light with a wavelength of 532 nm from the 1064-nm infra-red radiation output by an Nd:YAG laser by means of frequency doubling. The crystal is suitable in a number of respects, such as its strongly non-linear optical characteristics, and its low absorption of radiation at the original frequency and double the frequency.

REQUIRED APPARATUS

Quantity	Description	Number
1	Laser Diode Driver and Two-Way Temperature Controller Dsc01-2.5	1008632
1	Optical Bench KL	1008642
1	Diode Laser 1000 mW	1009497
1	Nd:YAG Cristal	1008635
1	Frequency Doubling Module	1008636
1	Laser Mirror II	1008639
1	PIN Photodiode	1008640
1	Filter BG40	1017874
1	Alignment Laser Diode	1008634
1	Transport Case KL	1008651
1	Laser Safety Goggles for Nd:YAG Laser	1002866
1	Digital Multimeter P3340	1002785
1	HF Patch Cord, BNC/4 mm Plug	1002748
1	IR Detector Card	1017879

3

WARNING

This experiment involves operation of class-4 laser equipment which emits light in the (invisible) infra-red part of the spectrum. Goggles which protect against laser light should always be worn. Even when wearing such goggles, never look at the laser beam directly.

BASIC PRINCIPLES

Materials often change their optical properties in strong electromagnetic fields. For instance, it is possible for the frequency of high-intensity laser light passing through such materials to be doubled. To describe such phenomena it is necessary to consider the polarisation, which changes in a way which is not linearly proportional to electric field strength:

If the material is non-magnetic, the wave equation for the electric field strength E has the following form:

$$(1) \quad \Delta \mathbf{E}(\mathbf{r}, t) - \frac{1}{c^2} \cdot \frac{\partial^2 \mathbf{E}(\mathbf{r}, t)}{\partial t^2} = \frac{1}{\epsilon_0 \cdot c^2} \cdot \frac{\partial^2 \tilde{\mathbf{P}}(\mathbf{r}, t)}{\partial t^2}$$

$\tilde{\mathbf{P}}$: Polarisation of the material
 ϵ_0 : Electric field constant
 c : Speed of light

The relationship between polarisation and field strength is non-linear and is described by the following equation:

$$(2) \quad \tilde{\mathbf{P}}(t) = \epsilon_0 \cdot (\chi_1 \cdot E(t) + \chi_2 \cdot E(t)^2)$$

χ_1, χ_2 : First- and second-order susceptibilities

Correspondingly, an electric field oscillating at a frequency f and described by the equation

$$(3) \quad E(t) = E_0 \cdot \exp(i \cdot 2\pi \cdot f \cdot t)$$

produces polarisation comprising two components. The component

$$(4) \quad \tilde{\mathbf{P}}_1(t) = \epsilon_0 \cdot \chi_1 \cdot E_0 \cdot \exp(i \cdot 2\pi \cdot f \cdot t)$$

oscillates at the original frequency f and describes how the speed of light changes inside the material. The component

$$(5) \quad \tilde{\mathbf{P}}_2(t) = \epsilon_0 \cdot \chi_2 \cdot E_0^2 \cdot \exp(i \cdot 2\pi \cdot 2f \cdot t)$$

oscillates at double the frequency, $2f$, and acts as a source for a new component of the electromagnetic field in accordance with equation (1).

When regarded at photon level, this means that two photons with a frequency f are converted into one photon with a frequency $2f$ (see Figure 1). Due conservation of momentum, the yield here is especially large if the mismatch in phases closely approximates to zero.

$$(6) \quad \Delta k \cdot \frac{L}{2} = \left| 2 \cdot \frac{2\pi}{\lambda_1} - \frac{2\pi}{\lambda_{2f}} \right| \cdot \frac{L}{2} = \frac{2\pi}{c} \cdot f \cdot L \cdot |n_1 - n_{2f}|$$

L : Length of resonator

λ_1, λ_{2f} : Wavelengths in the material at the original frequency and double the frequency

The refractive indices of the material n_1 and n_{2f} should therefore match as far as possible. This can be achieved in birefringent materials with a high degree of anisotropy in three dimensions if they are suitably aligned (see Fig 2). As a consequence, the yield depends on the spatial alignment of the frequency-doubling material.

The power density P_{2f} of the new radiation has a quadratic relationship with the power density P_1 of the fundamental radiation. The following applies:

$$(7) \quad P_{2f} = P_1^2 \cdot \frac{L^2}{A} \cdot C \cdot F\left(\Delta k \cdot \frac{L}{2}\right) \quad \text{where } F(x) = \left(\frac{\sin x}{x}\right)^2$$

A : Cross-sectional area of resonator

C : Material constant at the given wavelength

In this experiment, a crystal of KTiOPO_4 is used to generate green light with a wavelength of 532 nm from the 1064-nm infra-red radiation output by an Nd:YAG laser by means of frequency doubling. The crystal is suitable in a number of respects, such as its strongly non-linear optical characteristics, and its low absorption of radiation at the original frequency and double the frequency.

EVALUATION

To prove that the output depends on the square of the primary power P_1 , use is made of the fact demonstrated in the previous experiment that the power depends on the laser diode's injection current I .

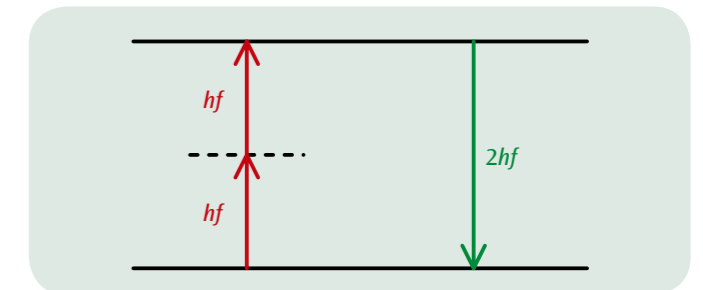

Figure 1: Schematic representation of frequency doubling

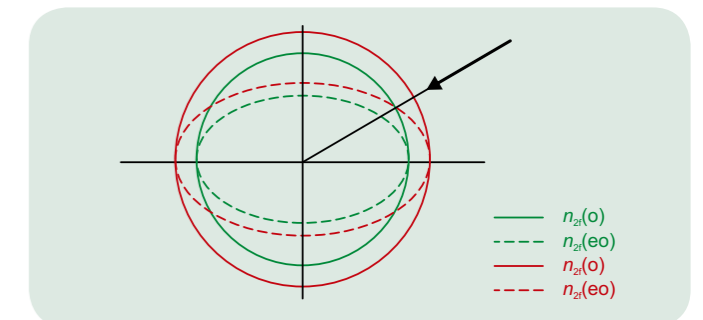

Figure 2: Schematic representation of phase matching through use of birefringence in the material

$n(o)$: Refractive index for ordinary ray

$n(eo)$: Refractive index for extraordinary ray

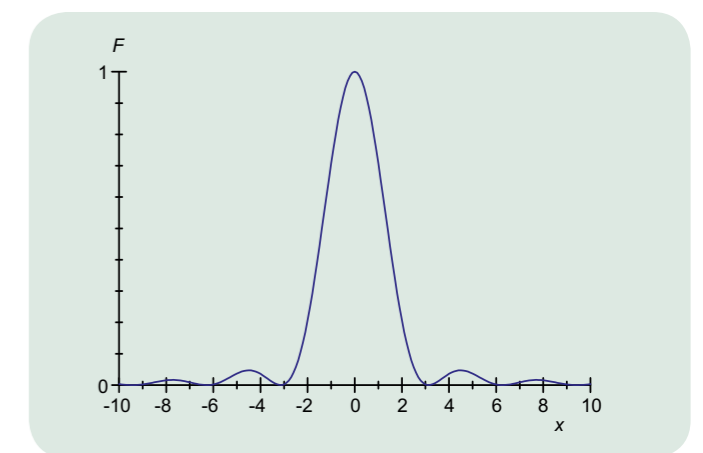

Figure 3: Representation of the function $F(x)$



EXPERIMENT PROCEDURE

- Measure the cut-off value of the decelerating voltage as a function of the wavelength of light.
- Plot the results in a graph of energy against frequency.
- Determine Planck's constant and the work required to emit an electron.
- Demonstrate that the energy of the electrons does not depend on the intensity of the light.

OBJECTIVE

Determine Planck's constant using the decelerating voltage method

SUMMARY

In a modified version of a classic set-up, light of known frequency passes through a ring-shaped anode to collide with a cathode, where it causes electrons to be released due to the photo-electric effect. The energy of the electrons can be determined by applying a decelerating voltage, which compensates for the flow of electrons towards the anode until no electrons are flowing. This demonstrates that the cut-off value of the decelerating voltage which corresponds to a current of zero is not dependent on the intensity of the light. The energy of the electrons is therefore similarly independent of intensity. By obtaining the cut-off voltages for light of varying frequency, it is possible to calculate Planck's constant.

REQUIRED APPARATUS

Quantity	Description	Number
1	Planck's Constant Apparatus (230 V, 50/60 Hz)	1000537 or
	Planck's Constant Apparatus (115 V, 50/60 Hz)	1000536

1

BASIC PRINCIPLES

The photoelectric effect exhibits two important properties, which were discovered in 1902 by *Lenard*. The number of electrons emitted from the cathode material as a result of the photoelectric effect is proportional to the intensity of the incident light. However, the energy is dependent on the frequency of the light and not on its intensity. In 1905, *Einstein* used a hypothesis based on the description of black body radiation discovered by *Planck* to explain this and thereby laid important foundations for quantum mechanics.

Einstein assumed that light propagates in the form of photons possessing energy proportional to the frequency of the light. If a photon of energy

$$(1) \quad E = h \cdot f,$$

$$h = 6.626 \times 10^{-34} \text{ Js: Planck's constant}$$

strikes an electron inside the cathode material, its energy can be transferred to the electron, which is then emitted from the cathode with kinetic energy

$$(2) \quad E_{\text{kin}} = h \cdot f - W$$

The work W required for emission of the electron is a quantity which is dependent on the nature of the material, its value for caesium for example is approximately 2 eV.

In this experiment, the above relationship is used to determine Planck's constant h . Light of a specific frequency f passes through a ring-shaped anode and strikes a cathode, causing electrons to be released. The resulting current from cathode to anode is then measured using a nanoammeter and a decelerating voltage U_0 is applied in order to reduce the current to zero. The light from various LEDs is used. The spectrum of the respective components is sufficiently narrow that a distinctive wavelength λ can be assigned to each of them, from which the frequency can be obtained as follows:

$$(3) \quad f = \frac{c}{\lambda}$$

$$c = 2.998 \times 10^8 \text{ m/s}$$

The intensity of the light from the diodes can be varied between 0% and 100%, meaning that it is possible to investigate how the energy of the electrons depends on the intensity of the light.

EVALUATION

In each case, the current is compensated to a value of zero at the cut-off value of the decelerating voltage U_0 . This definition can be summarised using equations (2) and (3) as follows

$$e \cdot U_0 = h \cdot f - W = h \cdot \frac{c}{\lambda} - W$$

where $e = 1.602 \times 10^{-19} \text{ As}$: elementary charge

Planck's constant can therefore be determined from the slope of a graph where values $E = e \cdot U_0$ are plotted along the y-axis and values of $f = \frac{c}{\lambda}$ are plotted along the x-axis.

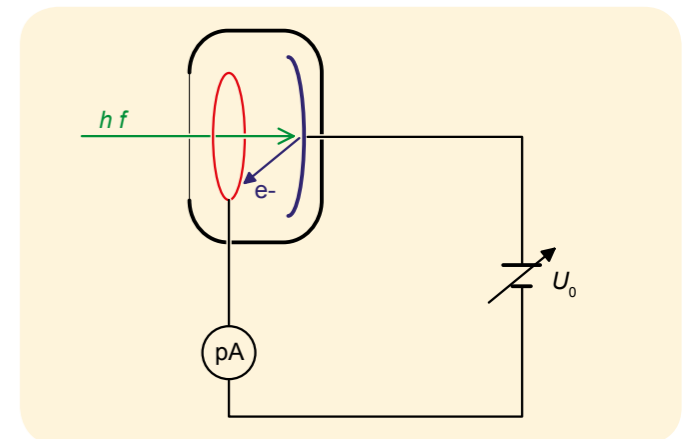

Fig. 1: Schematic of set-up for measurements

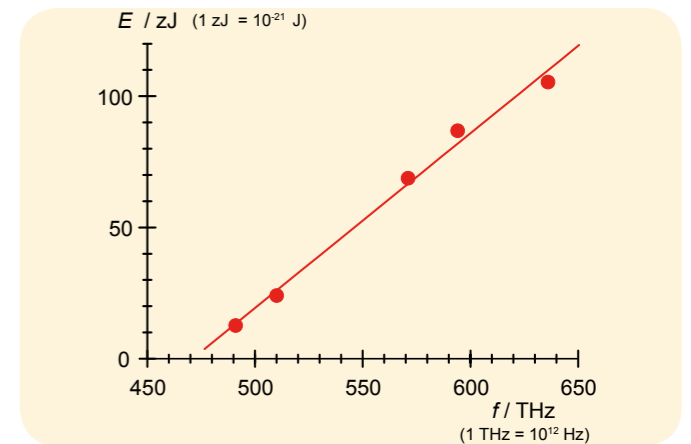

Fig. 2: Graph of energy against frequency

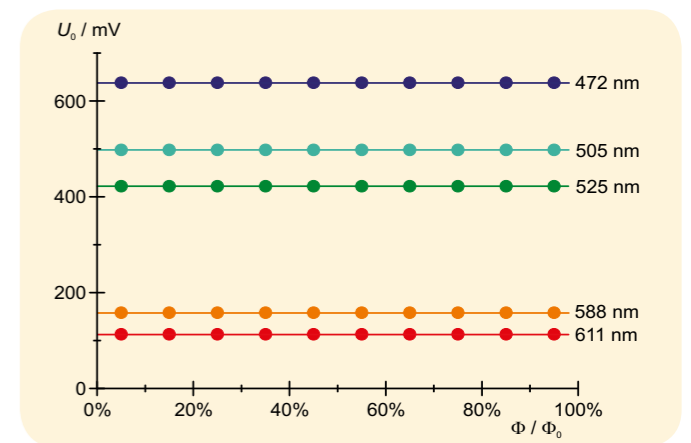

Fig. 3: Cut-off voltage U_0 as a function of intensity



EXPERIMENT PROCEDURE

- Display individual atoms on the surface of a graphite sample, analyse the lattice structure and how the atomic bonds are related.
- Display the surface of a gold sample and measure steps in the atomic structure.

OBJECTIVE

Viewing the atomic structure on the surface of graphite and gold

SUMMARY

A scanning tunnelling microscope is used for microscopic investigation of electrically conducting materials with resolution down to atomic level. The scanning probe is a sharp needle which scans the surface of the sample from a distance of only a few atomic diameters. The tunnelling current between the probe and the sample is measured and kept constant by varying the distance of the probe from the sample. The altered variables are mapped to an image of the sample's surface which shows the electrical conductivity superimposed on the topography of the sample.

REQUIRED APPARATUS

Quantity	Description	Number
1	Scanning Tunnelling Microscope	1012782
Additionally recommended:		
1	TaSe ₂ -Sample	1012875

BASIC PRINCIPLES

A scanning tunnel microscope is equipped with a very sharp probe, which is moved close enough to the surface of a conducting material, so that application of a bias potential between the probe and the sample results in a current due to quantum tunnelling. Minimal changes in the distance between the probe and the sample of as little as 0.01 nm lead to measurable changes in the tunnelling current, since the probability of tunnelling is related exponentially to the separating distance. This allows the atomic structure of surfaces to be scanned by moving the probe of the surface row by row and modifying the distance in such a way that the tunnelling current remains constant. The movements made are plotted in real time during the scan to create an image which can be viewed on a computer. The image shows the electrical conductivity of the of the sample surface superimposed on its topography.



In this experiment, the first task is to make a probe out of platinum-iridium alloy. The aim, if possible, is to create a tip so sharp that it is only one atom across. In order to prepare the graphite surface, it is cleaned by pulling off an adhesive strip. For other samples, it is sufficient to check that they are free of grease.

Obtaining a good image with resolution down to atomic level requires a sharp tip, a smooth sample surface and care in carrying out the experiment. Each time one of the measurement parameters changes, the probe should always be scanned over the sample multiple times before the final image is obtained. Only after that it is sensible to change any measurement parameter anew.

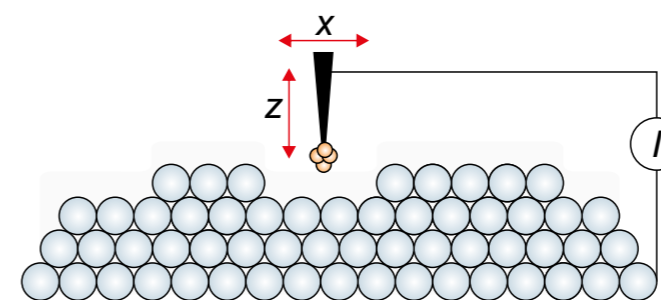

Fig. 1: Schematic diagram of tunnelling current

EVALUATION

In the image of graphite's hexagonal structure there are alternating carbon atoms which are shown as light or dark: The lighter ones are atoms with no immediate neighbours and the others have an immediate neighbour in the layer of atoms beneath. The former atoms appear lighter because they have a greater electron density. In order to measure distances and angles between atoms identified in this way, you can use the software's measurement tools. When investigating the surface of gold, it is possible to identify steps in the atomic structure comprised of single atoms, the height of which can be measured.

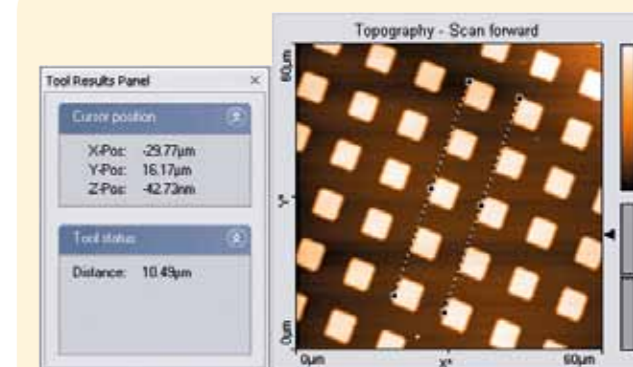
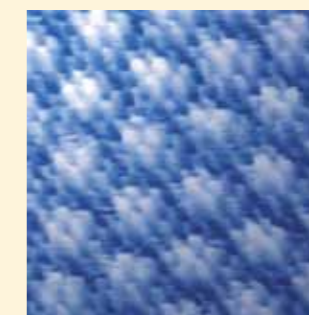

Fig. 2: Determining separation of atoms

Display of a gold surface



Display of the surface of TaSe₂ with standing waves in the charge density



Display of the hexagonal structure of a graphite surface

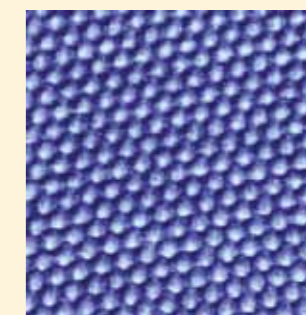



OBJECTIVE

Observe the diffraction of electrons on polycrystalline graphite and confirm the wave nature of electrons

EXPERIMENT PROCEDURE

- Measuring the diameters of the two diffraction rings for different accelerator voltages.
- Determining the wavelength of the electrons for different accelerator voltages by applying the Bragg condition.
- Confirming the de Broglie equation for the wavelength.

SUMMARY

The diffraction of electrons on a polycrystalline graphite foil provides evidence for the wave nature of electrons. It is possible to observe two diffraction rings surrounding a central spot on the axis of the beam on the fluorescent screen of the electron diffraction tube. These rings are caused by the diffraction of electrons at those lattice planes of the microcrystals in the graphite foil that satisfy the Bragg condition. The phenomenon is similar to the results obtained in the Debye-Scherrer diffraction of X-rays by a crystalline powder.

REQUIRED APPARATUS

Quantity	Description	Number
1	Electron Diffraction Tube S	1013889
1	Tube Holder S	1014525
1	High Voltage Power Supply 5 kV (230 V, 50/60 Hz)	1003310 or
	High Voltage Power Supply 5 kV (115 V, 50/60 Hz)	1003309
1	Set of 15 Safety Experiment Leads, 75 cm	1002843

BASIC PRINCIPLES

In 1924 *Louis de Broglie* put forward the hypothesis that particles can in principle also possess wave properties, and that the wavelength depends on the momentum. His theories were later confirmed by *C. Davisson* and *L. Germer* by observing the diffraction of electrons by crystalline nickel.

According to de Broglie, the relation between the wavelength λ of a particle and its momentum p is given by:

$$(1) \quad \lambda = \frac{h}{p}$$

h : Planck's constant.

For electrons that have been accelerated by a voltage U_A , this leads to the equation



(2)

$$\lambda = \frac{h}{\sqrt{2 \cdot m \cdot e \cdot U_A}}$$

m : Mass of the electron, e : Elementary electric charge.

For example, if the accelerator voltage is 4 kV, one can assign to the electrons a wavelength of about 20 pm.

In the experiment, the wave nature of electrons in an evacuated glass tube is demonstrated by observing their diffraction by polycrystalline graphite. On the fluorescent screen of the tube one observes diffraction rings around a central spot on the axis of the beam. The diameter of the rings depends on the accelerator voltage. They are caused by diffraction of electrons at those lattice planes of the microcrystals that satisfy the Bragg condition:

(3)

$$2 \cdot d \cdot \sin \vartheta = n \cdot \lambda$$

ϑ : the Bragg angle, n : Diffraction order, d : Distance between the lattice planes

(see Fig. 2). The diameter of the diffraction ring corresponding to the Bragg angle ϑ is given by:

(4)

$$D = 2 \cdot L \cdot \tan 2\vartheta$$

L : Distance between the graphite foil and the fluorescent screen.

As graphite has a crystal structure with two different lattice plane distances, $d_1 = 123$ pm and $d_2 = 213$ pm (see Fig. 3), the first-order diffraction pattern ($n = 1$) consists of two diffraction rings with diameters D_1 and D_2 .

EVALUATION

From the diameters of the two diffraction rings and the distances between the lattice planes, we can determine the wavelength λ by applying the Bragg condition. For small diffraction angles the following equation is valid:

$$\lambda = 2 \cdot d_{1/2} \cdot \sin \left(\frac{1}{2} \cdot \arctan \left(\frac{D_{1/2}}{2 \cdot L} \right) \right)$$

The experimental wavelengths thus calculated can be compared with the values calculated from the theoretical expression (2).

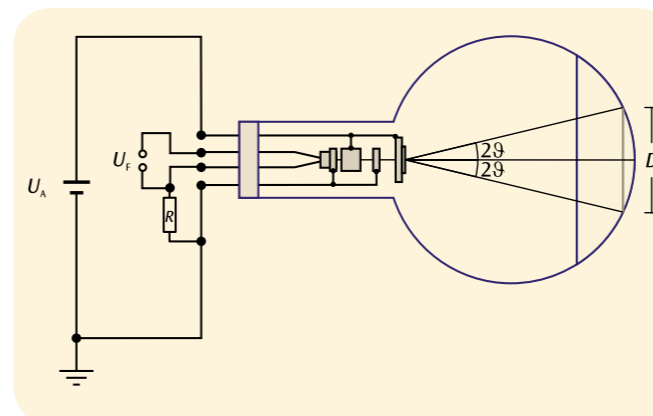

Fig. 1: Schematic diagram of the electron diffraction tube

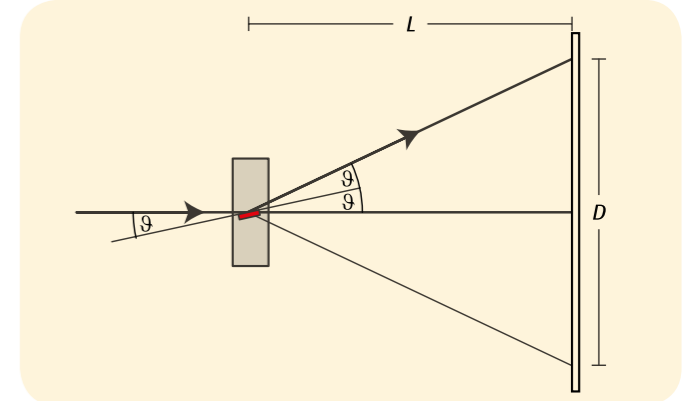

Fig. 2: Bragg reflection at a "favourable" group of lattice planes in a typical crystallite of the graphite foil

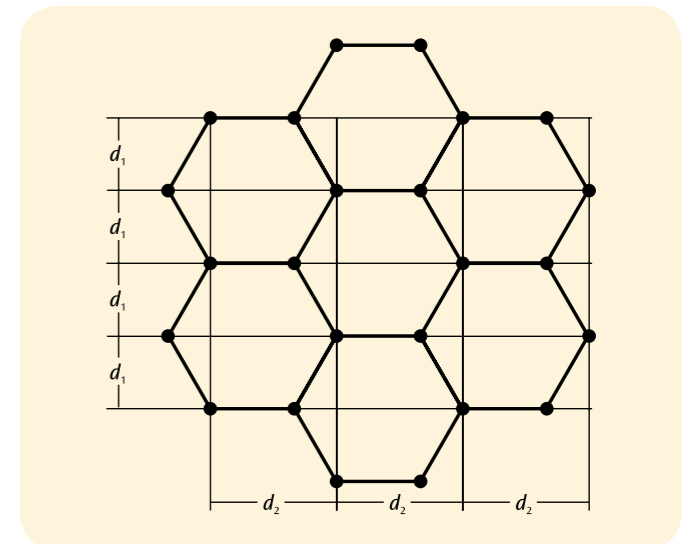

Fig. 3: The crystal structure of graphite

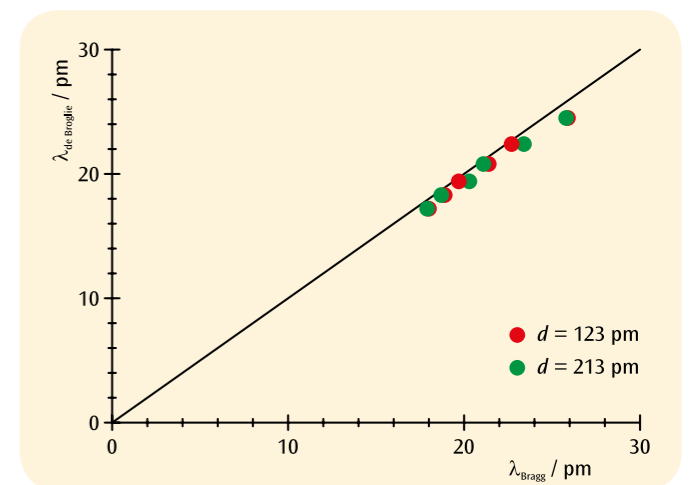

Fig. 4: The relation between wavelengths determined experimentally using the Bragg condition and the theoretical de Broglie wavelengths



EXPERIMENT PROCEDURE

- Record the line spectrum of hydrogen.
- Determine the frequencies of the H_{α} , H_{β} , H_{γ} and H_{δ} lines of the Balmer series for hydrogen.
- Calculate the Rydberg constant.
- Record and interpret line spectra of inert gases and metal vapours.

OBJECTIVE

Record and interpret the Balmer series of lines for hydrogen other line spectra in the visible region

SUMMARY

The line spectra of light-emitting atoms are uniquely characteristic for each specific chemical element, although they become increasingly complex for elements with higher atomic numbers. By contrast, that part of the line spectrum of hydrogen atoms that lies within the visible region can be explained simply on the basis of the Bohr model of the atom.

REQUIRED APPARATUS

Quantity	Description	Number
1	Digital-Spectrometer LD	1018103
1	Spectrum Tube Power Supply (230V, 50/60 Hz)	1000684 or
	Spectrum Tube Power Supply (115V, 50/60 Hz)	1000683
1	Spectrum Tube Hydrogen	1003409
1	Barrel Foot, 1000 g	1002834
Additionally recommended:		
1	Spectrum Tube Helium	1003408
1	Spectrum Tube Neon	1003413
1	Spectrum Tube Argon	1003403
1	Spectrum Tube Krypton	1003411
1	Spectrum Tube Mercury	1003412
1	Spectrum Tube Bromine	1003404
1	Spectrum Tube Iodine	1003410

2

BASIC PRINCIPLES

Light emitted by atoms of an electronically excited gas gives rise to spectra consisting of many individual lines, which are clearly distinguishable from one another, although they may be quite tightly packed in some parts of the spectrum. The lines are uniquely characteristic for each chemical element, because each line corresponds to a transition between particular energy levels in the electron shell of the atom.

The emission spectrum of hydrogen atoms has four lines, H_{α} , H_{β} , H_{γ} and H_{δ} , in the visible region. The spectrum continues into the ultra-violet region to form a complete series of spectral lines. In 1885 J. J. Balmer discovered that the frequencies of this series fit an empirical formula:

$$(1) \quad \nu = R \cdot \left(\frac{1}{2^2} - \frac{1}{n^2} \right)$$

$$n = 3, 4, 5, 6 \dots$$

$$R = 3290 \text{ THz: Rydberg constant.}$$

Later, with the aid of the Bohr model of the atom, it was shown that the frequency series could be explained simply in terms of the energy released by an electron when it undergoes downward transitions from higher shells to the second shell of a hydrogen atom.

The line spectrum of a helium atom, which contains only one more electron than hydrogen, is already much more complex, because the spin of the two electrons can be oriented in parallel or anti-parallel, so that they occupy completely different energy levels in the helium atom.

The complexity increases further for all other chemical elements. However, in every case the line spectrum is uniquely characteristic of the element.

EVALUATION

When the frequencies ν of the Balmer series are plotted as a function of $1/n^2$, with the H_{α} line assigned to $n = 3$, the H_{β} line to $n = 4$, and so on, the points lie on a straight line (see Fig. 1).

The gradient of the line corresponds to the Rydberg constant R . The intercept where the curve crosses the x-axis is at about 0.25, as a consequence of the fact that the transitions of the Balmer series go down to the $n = 2$ energy level.

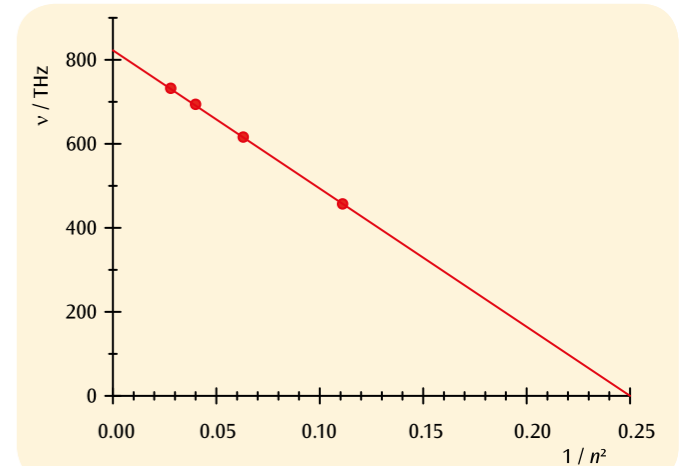

Fig. 1: Transition frequencies of the Balmer series as a function of $1/n^2$

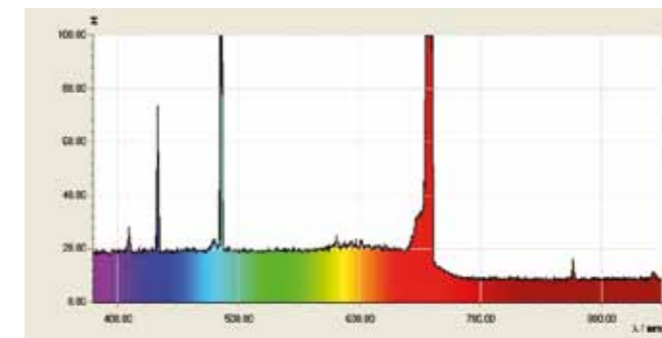

Fig. 2: Line spectrum of hydrogen atoms

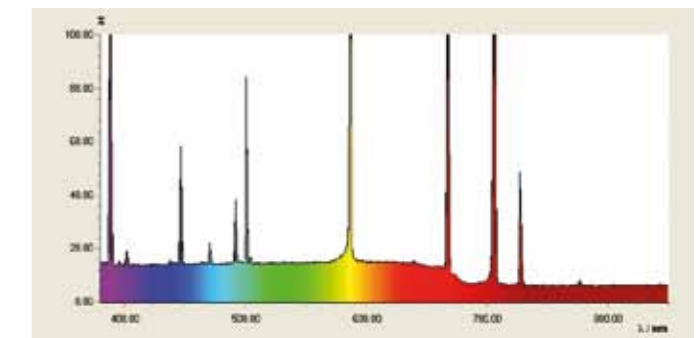

Fig. 3: Line spectrum of helium

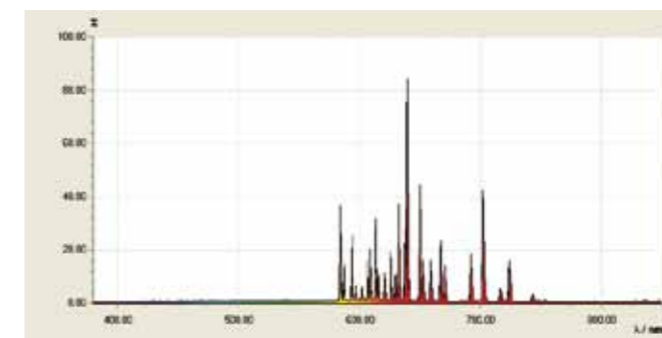

Fig. 4: Line spectrum of neon

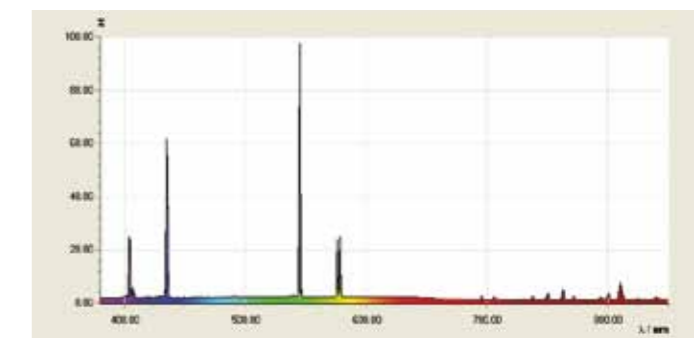

Fig. 5: Line spectrum of mercury vapour



EXPERIMENT PROCEDURE

- Demonstrate the fine structure of the sodium D-lines
- Measure absorption lines in the spectrum of the sun.
- Carry out high-precision measurements for other atoms.

OBJECTIVE

Carry out high-precision measurements of absorption and emission lines

SUMMARY

The resolution of a spectrometer is often assessed in terms of whether the two sodium D-lines can be distinguished. This experiment uses a digital spectrometer with the resolution to do this.

REQUIRED APPARATUS

Quantity	Description	Number
1	Digital-Spectrometer HD	1018104
1	Control Unit for Spectrum Lamps (230 V, 50/60 Hz)	1003196 or
	Control Unit for Spectrum Lamps (115 V, 50/60 Hz)	1003195
1	Spectral Lamp Na	1003541
2	Barrel Foot, 1000 g	1002834
Additionally recommended:		
1	Spectral Lamp Hg 100	1003545
1	Spectral Lamp Hg/Cd	1003546

2

BASIC PRINCIPLES

The resolution of a spectrometer characterises the performance of such a device. It is a measure of the minimum separation in terms of wavelength which must be exhibited by two adjacent spectral lines in order for them to be distinguished. One particularly well known pair of lines is the doublet making up the sodium D line. The separation in wavelength between these two lines is 0.6 nm. The resolution of a spectrometer is often assessed in terms of whether these two lines can be separated.

The sodium D-line occurs due to the transition of sodium 3s electrons from the excited 3p state down to the ground state. Since electron spin and orbital angular momentum are linked (Spin-orbit interaction), the 3p state is separated into two finely distinguished states with overall spin $j = 1/2$ and $j = 3/2$. The energy difference between these two adjacent states is 0.0021 eV and the wavelengths associated with decay to the ground state are 588.9950 nm (D2) and 589.5924 nm (D1).

In this experiment a digital spectrometer capable of distinguishing the fine structure of the sodium D-line is used. Spectral dispersion of the incident light is effected by inserting a grating with 1200 lines/mm into a Czerny-Turner monochromator. It is possible to measure the spectral range between 400 nm and 700 nm across a CCD array of 3600 pixels. That means there is one pixel available for each wavelength interval of 0.08 nm. This enables a resolution of 0.5 nm to be achieved, enabling the fine structure of the sodium D-line to be measured.

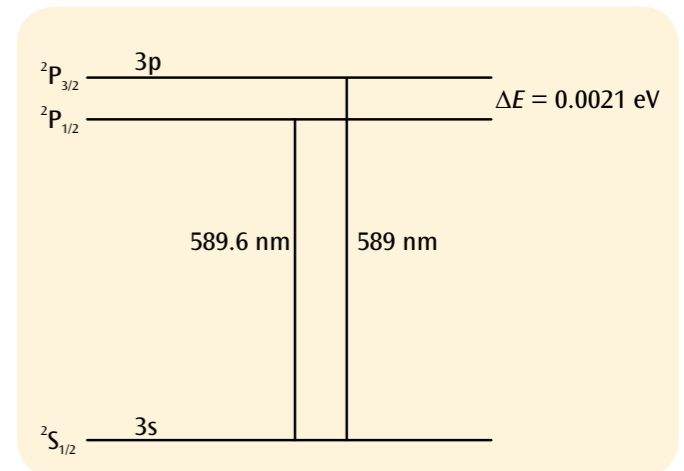

Fig. 1: Simplified energy level diagram for sodium

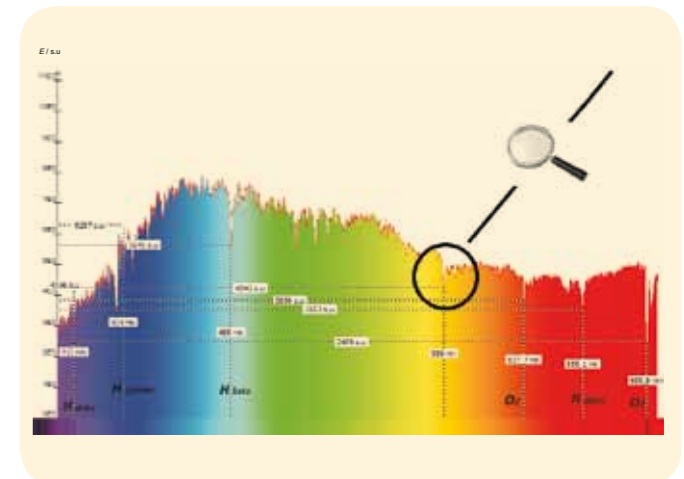

Fig. 2: Absorption lines in the spectrum of the sun

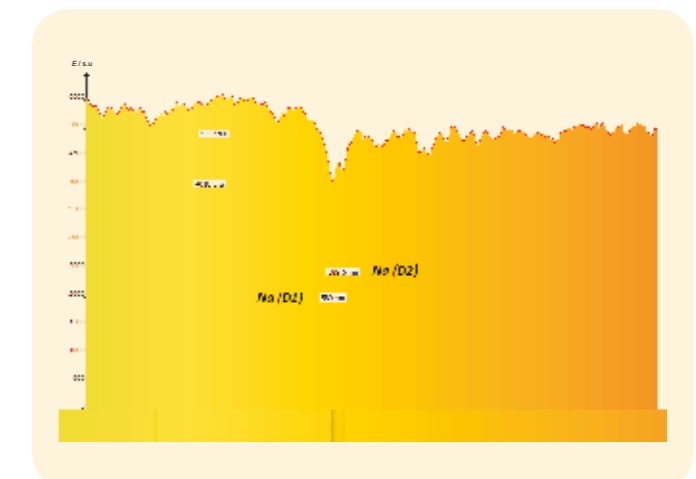
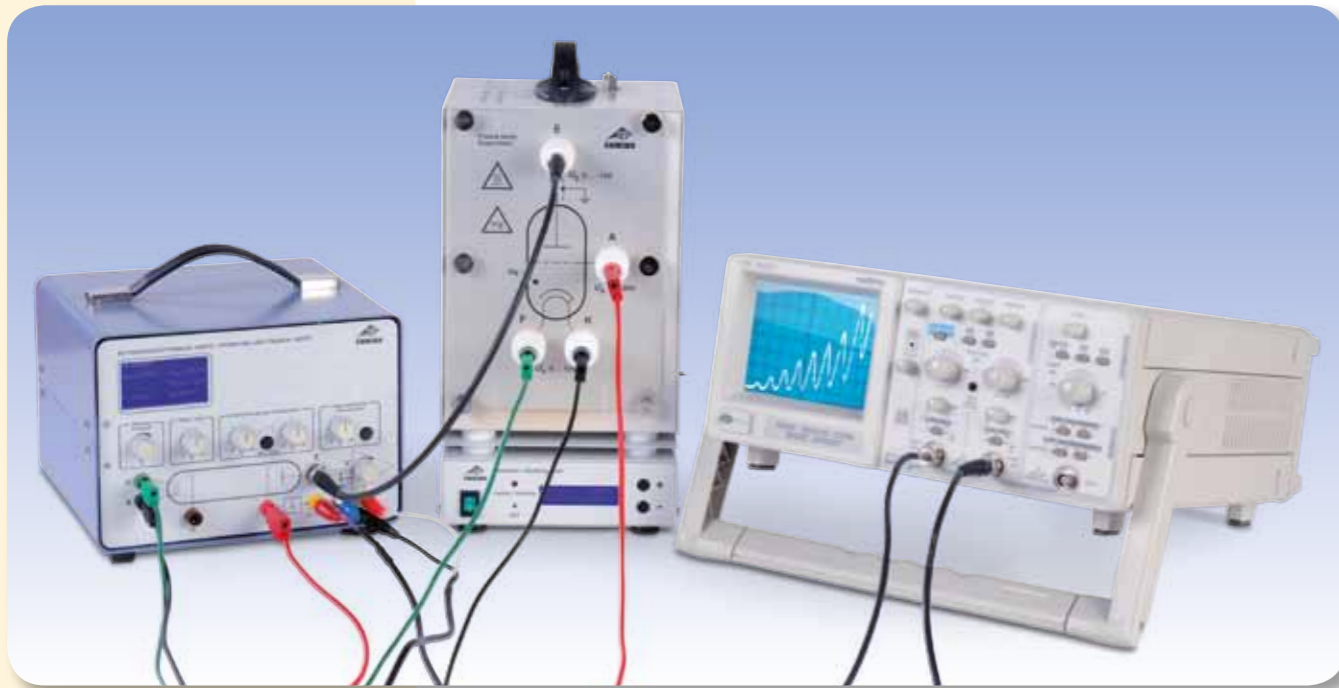

Fig. 3: Sodium absorption lines in the spectrum of the sun



EXPERIMENT PROCEDURE

- Measure target current I as a function of the voltage U between cathode and grid.
- Determining the separation ΔU of current maxima or minima.
- Compare the voltage intervals with the excitation energies of mercury atoms.

OBJECTIVE

Record and evaluate the Franck-Hertz curve for mercury

SUMMARY

The Franck-Hertz experiment for mercury involves observing how energy is transferred from electrons as a result of inelastic collision while passing through mercury vapour. The transfer of energy occurs in discrete steps corresponding to the excitation by such collision of distinct energy level transitions in the mercury atoms. The experiment thus provides confirmation of the Bohr model of the atom and the discrete energy levels described by that model.

REQUIRED APPARATUS

Quantity	Description	Number
1	Franck-Hertz Tube with Mercury Filling and Heating Chamber (230 V, 50/60 Hz)	1006795 or
	Franck-Hertz Tube with Mercury Filling and Heating Chamber (115 V, 50/60 Hz)	1006794
1	Power Supply Unit for Franck-Hertz Experiment (230 V, 50/60 Hz)	1012819 or
	Power Supply Unit for Franck-Hertz Experiment (115 V, 50/60 Hz)	1012818
1	Analogue Oscilloscope, 2x30 MHz	1002727
1	Digital Multimeter P3340	1002785
1	HF Patch Cord	1002746
2	HF Patch Cord, BNC/4 mm Plug	1002748
1	Set of 15 Safety Experiment Leads, 75 cm	1002843

2

BASIC PRINCIPLES

James Franck and Gustav Hertz reported in 1914 that electrons passing through mercury vapour transferred energy in discrete steps and that this is associated with observing the emission of mercury's ultra-violet spectral line ($\lambda = 254$ nm). Niels Bohr realised several months later that this was a confirmation of the atomic model he had developed. The Franck-Hertz experiment with mercury has thus become a classic experiment for the confirmation of quantum theory.

An evacuated glass tube contains a heated cathode C, a grid G and a target electrode A placed in that sequence (see Fig. 1). Electrons are emitted from the cathode and are accelerated by a voltage U towards the grid. Having passed through the grid they reach the target and thus contribute to a target current I if their kinetic energy is sufficient to overcome a decelerating voltage U_{GA} between the grid and the target. In addition a glass tube with a droplet of mercury is included and this is heated to generate a vapour pressure of approximately 15 hPa.

As the voltage U increases the target current I initially increases since more and more atoms are attracted out of the space charge field around the cathode by the electric field.

At a certain value $U = U_1$ some atoms attain sufficient kinetic energy just in front of the grid so that they are able to provide sufficient energy to excite the mercury atoms by inelastic collision. The target current then drops to near zero since after such a collision, the electrons no longer have the energy to overcome the decelerating voltage.

As the voltage increases more, the electrons acquire enough energy to excite the mercury atoms further away from the grid. After such collisions they are accelerated again and can once again acquire enough energy to reach the target so the target current rises again.

At a still higher voltage $U = U_2$ the electrons can acquire so much energy after the first collision that they are able to excite another mercury atom. The target current once again drops drastically but rises once more as the voltage further increases. This continues for a third time at a still higher voltage and again the target current drops dramatically.

NOTE

The first minimum is not at 4.9 V itself but is shifted by an amount corresponding to the so-called contact voltage between the cathode and grid.

EVALUATION

The voltages U_1, U_2, U_3, \dots , at which the current dramatically drops in the recorded $I(U)$ -characteristics all appear at a constant interval $\Delta U = 4.9$ V. This interval corresponds to the excitation energy $E_{Hg} = 4.9$ eV ($\lambda = 254$ nm) at which mercury atoms are raised from the base state 1S_0 to the first 3P_1 -state. The following equation applies:

$$(1) \quad E_{Hg} = e \cdot \Delta U$$

e : Elementary electron charge

The results can thus be traced to discrete energy absorption by mercury atoms due to inelastic collision and the associated transfer of a fixed amount of energy from the electrons.

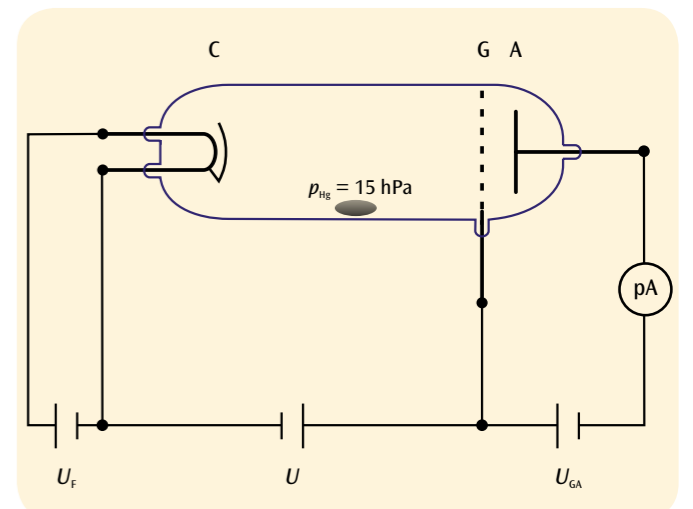

Fig. 1: Schematic of set up for measuring the Franck-Hertz curve for mercury

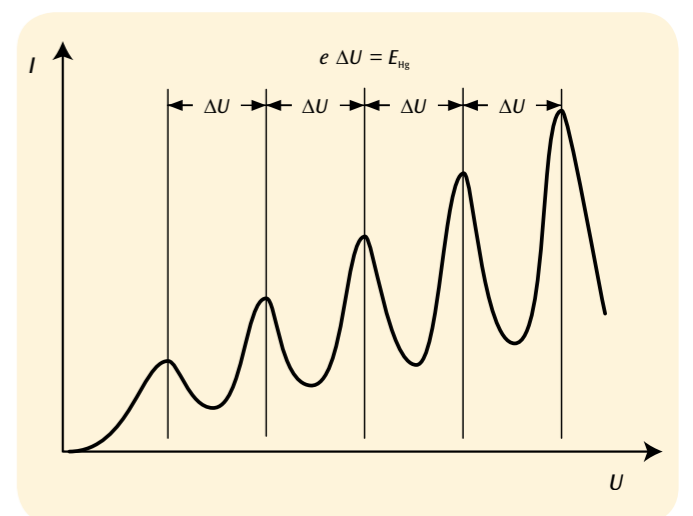
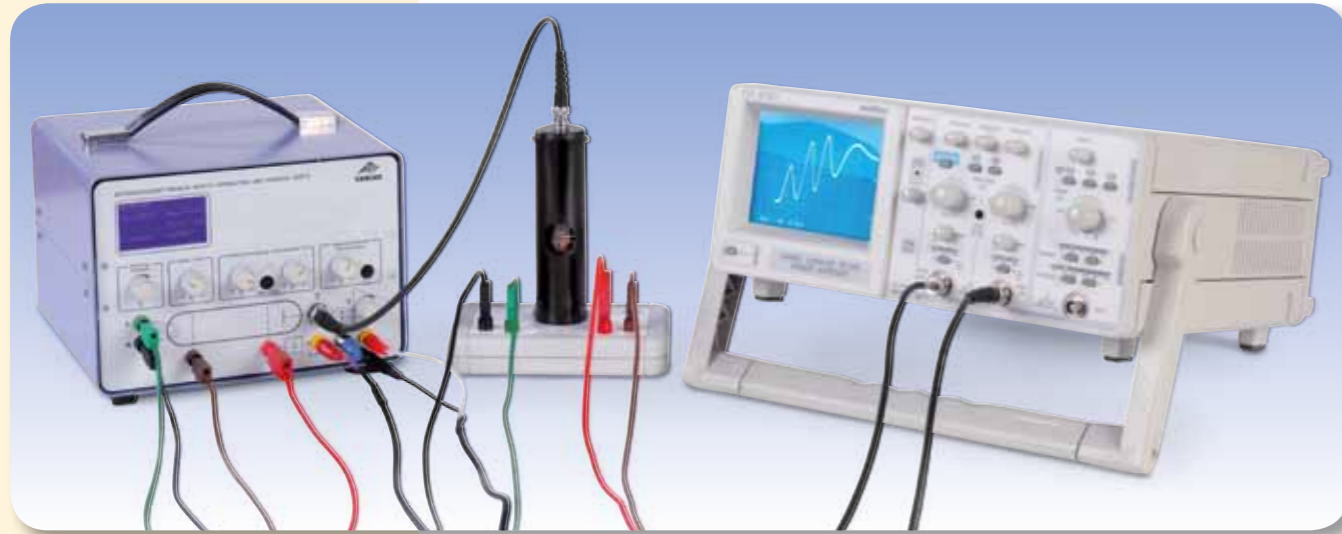

Fig. 2: Target current I as a function of the accelerating voltage U



EXPERIMENT PROCEDURE

- Measure target current I as a function of the voltage U between cathode and grid.
- Compare the distribution of current maxima with the excitation energies of neon atoms.
- Observe the light emitted by the excited neon atoms.
- Determine the number of light-emitting levels for various accelerating voltages.

OBJECTIVE

Record and evaluate the Franck-Hertz curve for neon and observe emission of light

SUMMARY

The Franck-Hertz experiment for neon involves observing how energy is transferred from electrons as a result of inelastic collision while passing through neon gas. The transfer of energy occurs in discrete steps corresponding to the excitation by such collision of distinct energy level transitions in the neon atoms. The excited atoms then emit visible light.

REQUIRED APPARATUS

Quantity	Description	Number
1	Franck-Hertz Tube with Ne Filling	1000912
1	Power Supply Unit for Franck-Hertz Experiment (230 V, 50/60 Hz)	1012819 or
	Power Supply Unit for Franck-Hertz Experiment (115 V, 50/60 Hz)	1012818
1	Analogue Oscilloscope, 2x30 MHz	1002727
1	Digital Multimeter P3340	1002785
1	HF Patch Cord	1002746
2	HF Patch Cord, BNC/4 mm Plug	1002748
1	Set of 15 Safety Experiment Leads, 75 cm	1002843

2

BASIC PRINCIPLES

In the Franck-Hertz experiment neon atoms are excited by inelastic collision with electrons. The excited atoms emit visible light that can be viewed directly. Thus it is possible to detect zones where the light and therefore the excitation is more intense. The distribution of such zones between the cathode and the grid depends on the difference in potential between the two.

An evacuated glass tube that has been filled with neon gas to a pressure of 10 hPa contains a heated cathode C, a control grid S, a grid G and a target electrode A arranged in that sequence (see Fig. 1). Electrons are emitted from the cathode and are accelerated by a voltage U towards the grid. Having passed through the grid they reach the target and thus contribute to a target current I if their kinetic energy is sufficient to overcome a decelerating voltage U_{GA} between the grid and the target.

The $I(U)$ -characteristic (see Fig. 2) has a similar pattern to the original Franck-Hertz experiment using mercury gas but this time the intervals between minima where the current falls to almost zero for a specific voltage $U = U_1$ corresponding to the electrons reaching sufficient kinetic energy to excite a neon atom by inelastic collision just before reaching the grid are about 19 V. Simultaneously it is possible to observe a faint orange light close to the grid since the energy transition to the base state of a neon atom results in the emission of such light. The zone of illumination moves towards the cathode as the voltage U increases and the target current I rises once more.

For a higher voltage $U = U_2$ the target current also drops drastically and it is possible to see two zones of illumination. The electrons can in this case retain enough energy after an initial collision to excite a second neon atom. As the voltages are further increased, other minima in the target current along with further zones of illumination can be observed.

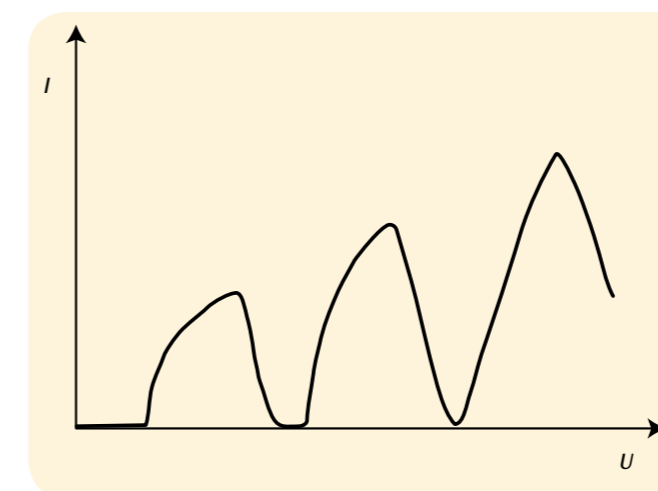

Fig. 2: Target current I as a function of the accelerating voltage U

EVALUATION

The $I(U)$ -characteristic exhibits various maxima and minima and the interval between the minima is about $\Delta U = 19$ V. This corresponds to excitation energy of the 3p energy level of a neon atom (see Fig. 3) so that it is highly likely that this level is being excited. Excitement of the 3s-level cannot be neglected entirely and gives rise to some fine detail in the structure of the $I(U)$ -characteristic.

The zones of illumination are zones of greater excitation and correspond to drops in voltage in the $I(U)$ -characteristic. One more zone of illumination is created every time U is increased by about 19 V.

NOTE

- The first minimum is not at 19 V itself but is shifted by an amount corresponding to the so-called contact voltage between the cathode and grid.
- The emission lines in the neon spectrum can easily be observed and measured using a spectroscope (1003184) when the maximum voltage U is used.

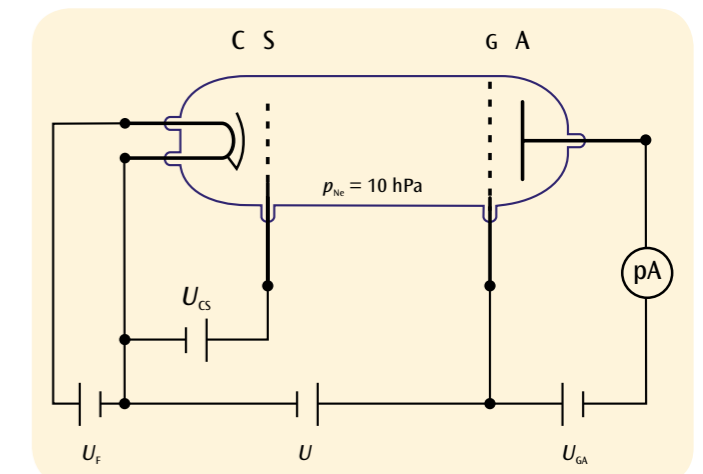

Fig. 1: Schematic of set up for measuring the Franck-Hertz curve for neon

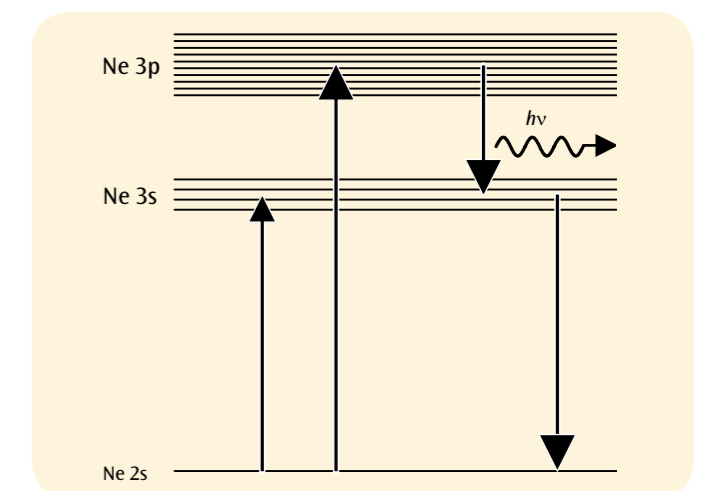

Fig. 3: Energy levels in neon atoms



EXPERIMENT PROCEDURE

- Measure the collector current I_R as a function of the accelerating voltage U_A .
- Compare the positions of the current maxima with the known critical potentials of the helium atom.
- Identify the doublet structure in the term scheme of helium (ortho and para helium).

OBJECTIVE

Determine the critical potentials of a helium atom

SUMMARY

The expression “critical potential” is a general name for all the excitation and ionisation energies in the electron shells of an atom. The corresponding electronic states can be excited in various ways, for example by inelastic collisions with electrons. If the kinetic energy of the electron corresponds to a critical potential, the electron can lose all its kinetic energy in an inelastic collision. An experiment set-up originally designed by Gustav Hertz is used here to determine critical potentials.

REQUIRED APPARATUS

Quantity	Description	Number
1	Critical Potential Tube S with He-Filling	1000620
1	Tube Holder S	1014525
1	Control Unit for Critical Potential Tubes (230 V, 50/60 Hz)	1008506 or
	Control Unit for Critical Potential Tubes (115 V, 50/60 Hz)	1000633
1	DC Power Supply 0 – 20 V, 0 – 5 A (230 V, 50/60 Hz)	1003312 or
	DC Power Supply 0 – 20 V, 0 – 5 A (115 V, 50/60 Hz)	1003311
1	Digital Multimeter P3340	1002785
1	USB Oscilloscope 2x50 MHz	1017264
2	HF Patch Cord, BNC/4 mm Plug	1002748
1	Set of 15 Safety Experiment Leads, 75 cm	1002843
1	3B NETlog™ (230 V, 50/60 Hz)	1000540 or
	3B NETlog™ (115 V, 50/60 Hz)	1000539
1	3B NETlab™	1000544

3

BASIC PRINCIPLES

The expression “critical potential” is a general name for all the excitation and ionisation energies in the electron shells of an atom. The corresponding electronic states of the atom can be excited in various ways, for example by inelastic collisions with electrons. If the kinetic energy of the electron corresponds exactly to a critical potential, the electron can transfer all its kinetic energy to the atom in an inelastic collision. Using an experiment set-up originally designed by Gustav Hertz, this effect can be used to determine the critical potentials.

In a tube that has been evacuated and then filled with helium, free electrons are accelerated by a voltage U_A to form a divergent beam passing through a space at a constant potential. To prevent the walls of the tube becoming charged, the inner surface is coated with a conducting material and connected to the anode A (see Fig. 1). In the tube there is a ring-shaped collector electrode R, through which the divergent beam can pass without touching it, even though the ring is at a slightly higher potential. However, a small current I_R , with a value in the order of picoamperes, is measured at the collector ring, and is found to depend on the accelerating voltage U_A . It shows characteristic maxima, which are caused by the fact that the electrons can undergo inelastic collisions with helium atoms during their passage through the tube. The kinetic energy E of an electron is as follows:

$$(1) \quad E = e \cdot U_A$$

e : Elementary electron charge

If this energy corresponds exactly to a critical potential of the helium atom, all the kinetic energy may be transferred to the helium atom. In this instance the electron can then be attracted and collected by the collector ring, thus contributing to an increased collector current I_R . As the accelerating voltage is increased, successively higher levels of the helium atom can be excited, until finally the kinetic energy of the electron is enough to ionise the helium atom. As the accelerating voltage is increased further, the collector current shows a steady increase.

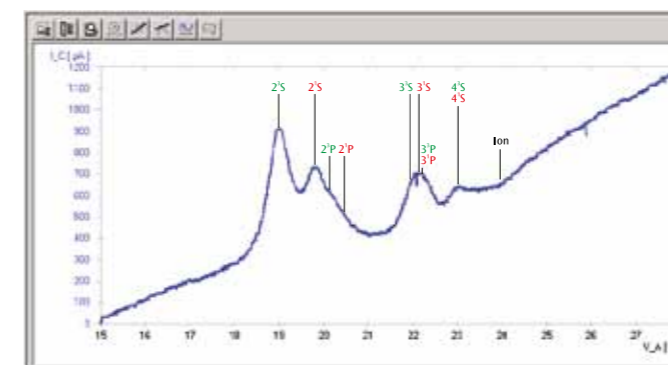

Fig. 3: Collector current I_R as a function of accelerating voltage U_A

EVALUATION

The positions of the observed current maxima are compared with quoted values for the excitation energies and the ionisation energy of the helium atom. Account must be taken of the fact that the maxima will be shifted relative to the quoted values by an amount corresponding to the so-called contact voltage between the cathode and the anode.

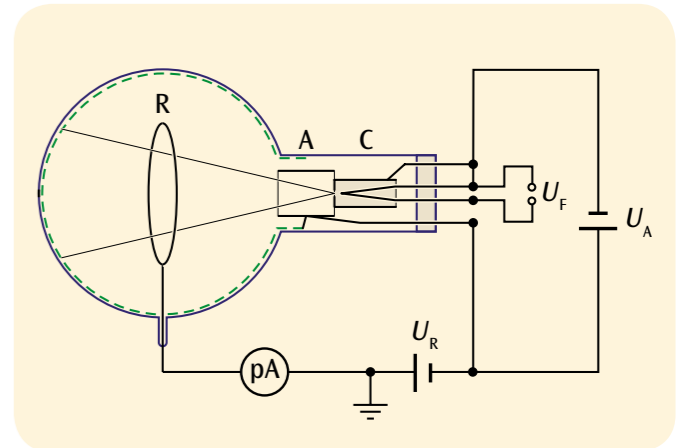

Fig. 1: Schematic diagram of critical potential tube

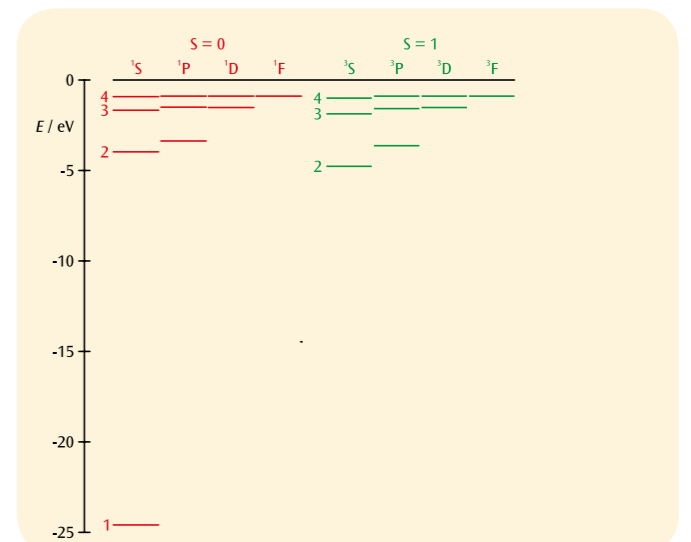

Fig. 2: The term scheme of helium
red: total spin $S = 0$ (para helium),
green: total spin $S = 1$ (ortho helium)



EXPERIMENT PROCEDURE

- Observe the resonance curve of DPPH.
- Determine the resonant frequency as a function of the magnetic field.
- Determine the Landé g -factor for free electrons.

OBJECTIVE

Demonstrate electron spin resonance in DPPH

SUMMARY

Electron spin resonance (ESR) is based on the energy absorption by substances with unpaired electrons, which are inside an external magnetic field produced by a DC source. The energy is absorbed from a high-frequency AC-generated field which is fed in perpendicular to the field from the DC source. If the frequency of the alternating field is equal to the resonant frequency, the impedance of the transmitting coil filled with the test material changes in accordance with a resonance curve and a peak will be visible on an oscilloscope screen. One suitable material for this is diphenyl-picryl-hydrazyl (DPPH).

REQUIRED APPARATUS

Quantity	Description	Number
1	ESR/NMR Basic Set (230 V, 50/60 Hz)	1000638 or
	ESR/NMR Basic Set (115 V, 50/60 Hz)	1000637
1	ESR Supplementary Set	1000640
1	Analogue Oscilloscope, 2x30 MHz	1002727
2	HF Patch Cord	1002746

3

BASIC PRINCIPLES

Electron spin resonance (ESR) is based on the energy absorption by substances with unpaired electrons, which are inside an external magnetic field produced by a DC source. The energy is absorbed from a high-frequency AC-generated field which is fed in perpendicular to the field from the DC source. If the frequency of the alternating field is equal to the resonant frequency, the impedance of the transmitting coil filled with the test material changes in accordance with a resonance curve and a peak will be visible on an oscilloscope screen. The cause of resonance absorption is the „tipping over“ of the magnetic moments between spin states of a free electron. The resonant frequency depends on the strength of the DC-generated field and the width of the resonance signal is related to the uniformity of the field.

The magnetic moment of an electron with purely spin-related magnetism assumes discrete values in a magnetic field B :

$$(1) \quad E_m = -g_j \cdot \mu_B \cdot m \cdot B, \quad m = -\frac{1}{2}, \frac{1}{2}$$

$$\mu_B = 9.274 \cdot 10^{-24} \frac{\text{J}}{\text{T}} : \text{Bohr magneton}$$

$$g_j = 2.0023: \text{Landé } g\text{-factor}$$

The interval between the two levels is therefore

$$(2) \quad \Delta E = g_j \cdot \mu_B \cdot B$$

Resonance occurs when the frequency f of the alternating field being fed in meets the following condition:

$$(3) \quad h \cdot f = \Delta E,$$

$$h = 6.626 \cdot 10^{-34} \text{ Js: Planck's constant}$$

In this experiment, electron spin resonance will be demonstrated in diphenyl-picrylhydrazyl (DPPH), an organic compound, the molecules of which include an unpaired electron. The basic magnetic field is generated inside a pair of Helmholtz coils and is moved between zero and a maximum value of $B_{\text{max}} = 3.5 \text{ mT}$ using a saw-tooth wave-form. Now it is possible to look for a frequency f , at which resonance absorption takes place at a distinct position along the saw-tooth curve, i.e. for a pre-selected magnetic field.

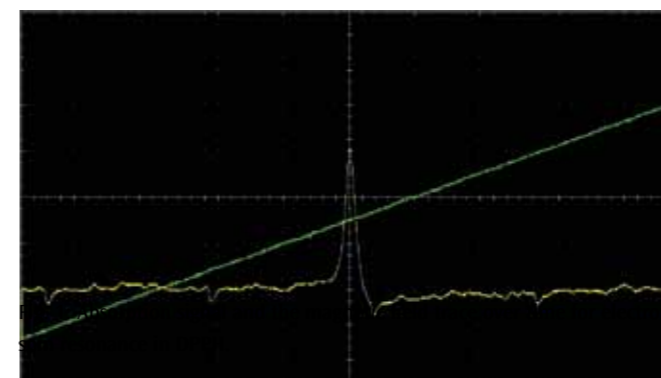

Fig. 1: Absorption signal and the magnetic field trace over time for electron spin resonance in DPPH

EVALUATION

The following relationship between the resonance frequency f and the magnetic field B can be derived from (2) and (3).

$$f = g_j \cdot \frac{\mu_B}{h} \cdot B$$

The measurements therefore lie along a straight line through the origin to within the measurement tolerances. The Landé g -factor can be determined from the slope of this graph.

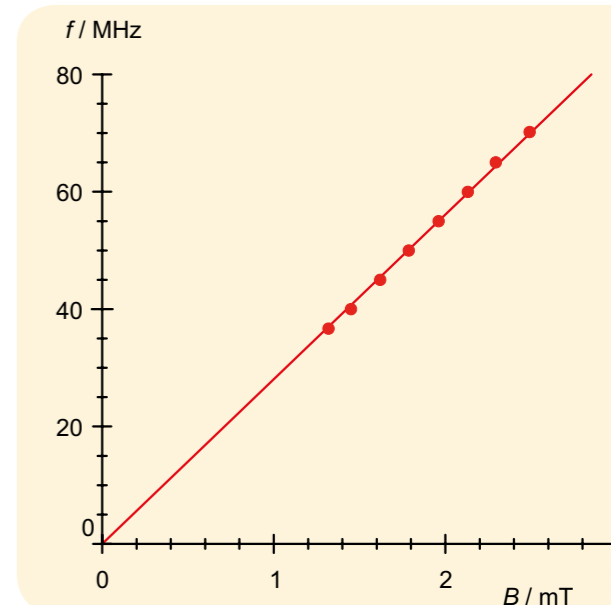

Fig. 2: Resonant frequency f as a function of the magnetic field B

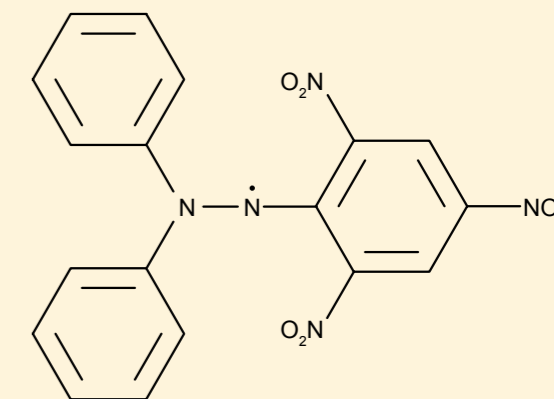

Fig.3: Molecular structure of DPPH



EXPERIMENT PROCEDURE

- Demonstrate nuclear magnetic resonance in glycerine, polystyrene and Teflon.
- Determine the resonant frequencies in a constant magnetic field.
- Make a comparison between the g -factors of ^1H and ^{19}F nuclei.

OBJECTIVE

Demonstrate and compare nuclear magnetic resonance in glycerine, polystyrene and Teflon

SUMMARY

Nuclear magnetic resonance (NMR) is based on the energy absorption by substances with nuclear magnetism, which are inside an external magnetic field produced by a DC source. The energy is absorbed from a high-frequency AC-generated field which is fed in perpendicular to the field from the DC source. If the frequency of the alternating field is equal to the resonant frequency, the impedance of the transmitting coil filled with the test material changes in accordance with a resonance curve and a peak will be visible on an oscilloscope screen. Suitable materials for this include glycerine, polystyrene and Teflon, whereby the magnetic moment of ^1H or ^{19}F nuclei is used.

REQUIRED APPARATUS

Quantity	Description	Number
1	ESR/NMR Basic Set (230 V, 50/60 Hz)	1000638 or
	ESR/NMR Basic Set (115 V, 50/60 Hz)	1000637
1	NMR Supplementary Set	1000642
1	Analogue Oscilloscope, 2x30 MHz	1002727
2	HF Patch Cord	1002746

3

BASIC PRINCIPLES

Nuclear magnetic resonance (ESR) is based on the energy absorption by substances with nuclear magnetism, which are inside an external magnetic field produced by a DC source. The energy is absorbed from a high-frequency AC-generated field which is fed in perpendicular to the field from the DC source. If the frequency of the alternating field is equal to the resonant frequency, the impedance of the transmitting coil filled with the test material changes in accordance with a resonance curve and a peak will be visible on an oscilloscope screen. The cause of resonance absorption is a transition between energy states of the nucleus' magnetic moment inside a magnetic field. The resonant frequency depends on the strength of the DC-generated field and the width of the resonance signal is related to the uniformity of the field.

The magnetic moment of a nucleus with nuclear spin I assumes discrete values in a magnetic field B :

$$(1) \quad E_m = -g_i \cdot \mu_k \cdot m \cdot B, \quad m = -I, -I+1, \dots, I$$

$$\mu_k = 5.051 \cdot 10^{-27} \frac{1}{1} \cdot \text{Nuclear magneton}$$

g_i : g -factor of atomic nucleus

The interval between the two levels is therefore

$$(2) \quad \Delta E = g_i \cdot \mu_k \cdot B$$

When the energy levels meet the condition for resonance, another magnetic field of frequency f applied perpendicular to the uniform field excites the transition between energy states. Resonance occurs when the frequency f precisely fulfils the following condition:

$$(3) \quad h \cdot f = \Delta E,$$

$$h = 6.626 \cdot 10^{-34} \text{ Js: Planck's constant}$$

In this experiment nuclear magnetic resonance will be demonstrated in glycerine, polystyrene and Teflon, whereby the ^1H isotope contributes to the resonance in glycerine and polystyrene while the ^{19}F isotope is the contributor in Teflon. The uniform magnetic field is largely generated by permanent magnets. Added to this is a magnetic field which varies in a saw-tooth pattern between zero and a maximum value generated inside a pair of Helmholtz coils. Now a frequency f can be found where resonance absorption takes place in a pre-selected magnetic field, which, for simplicity, we will take to be in the middle of the saw-tooth wave.

EVALUATION

The g -factors for the nuclei involved are quoted in literature to be as follows: $g_i(^1\text{H}) = 5.5869$ und $g_i(^{19}\text{F}) = 5.255$.

From (2) and (3) the following applies for the resonant frequency f in a magnetic field B .

$$f = g_i \cdot \frac{\mu_k}{h} \cdot B$$

The resonant frequencies for various nuclei in the same magnetic field therefore have the same ratios as the g -factors:

$$\frac{f(^{19}\text{F})}{f(^1\text{H})} = \frac{g_i(^{19}\text{F})}{g_i(^1\text{H})} = 94\%$$

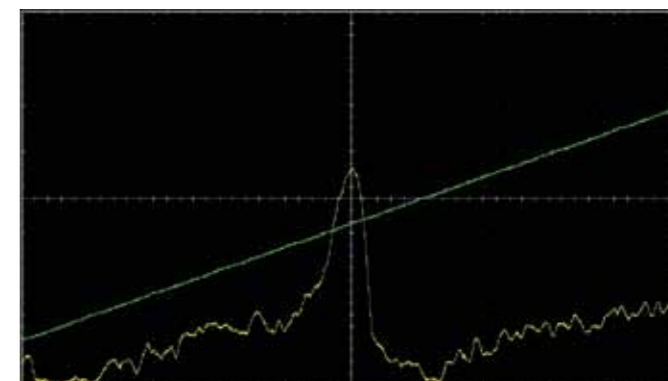

Fig. 1: Nuclear magnetic resonance in glycerine ($f = 12.854$ MHz)

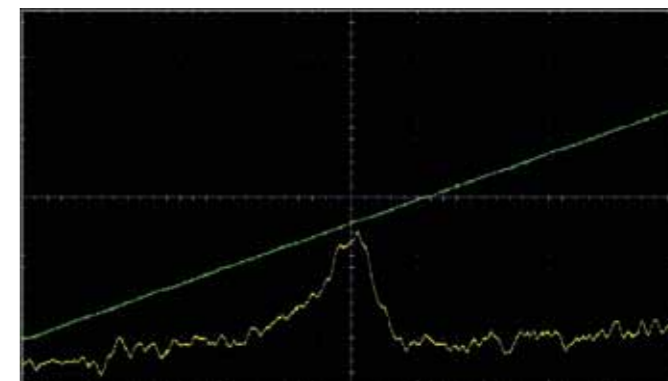

Fig. 2: Nuclear magnetic resonance in polystyrene ($f = 12.854$ MHz)

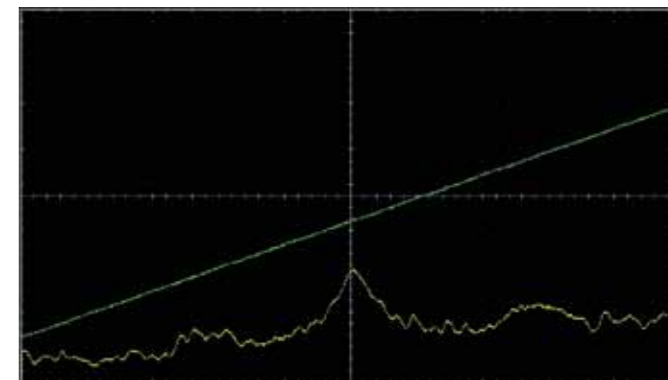

Fig. 3: Nuclear magnetic resonance in Teflon ($f = 12.1$ MHz)



OBJECTIVE

Determine band separation in germanium

SUMMARY

Semiconductors only exhibit measurable electrical conductivity at high temperatures. The reason for this dependence on temperature is the band structure of the electron energy levels, which comprise a conduction band, a valence band and an intermediate zone, which in pure, undoped semiconductor materials cannot be occupied by electrons at all. As the temperature increases, more and more electrons are thermally excited from the valence band into the conduction band, leaving behind "holes" in the valence itself.

These holes move under the influence of an electric field as if they were positive particles and contribute to the current much as electrons do.

In order to determine the conductivity of pure, undoped germanium, this experiment involves sending a constant current through the crystal and measuring the voltage drop as a function of temperature. The data measured can be described by an exponential function to a good approximation, whereby the separation of bands appears as a key parameter.

EXPERIMENT PROCEDURE

- Measure the electrical conductivity of undoped germanium as a function of temperature.
- Determine the band separation between the valence band and conduction band.

NOTE

In practice, the intrinsic conductivity of pure, undoped semiconductors is of minor importance. As a rule, the crystals have imperfections which adversely affect the flow of current. Often, highly pure crystals are specifically targeted by addition of donor or acceptor atoms to make them more conductive. The effect of such doping becomes apparent when the investigations described here are carried out to include comparison of n and p-doped germanium. The conductivity of the doped crystals at room temperature is much higher than that of pure crystals, although at high temperatures, it approaches the intrinsic conductivity, see Fig. 4. The way that Hall coefficients depend on temperature is investigated in greater detail in Experiment UE6020200.



REQUIRED APPARATUS

Quantity	Description	Number
1	Undoped Germanium on Printed Circuit Board	1008522
1	Hall Effect Basic Apparatus	1009934
1	Barrel Foot, 1000 g	1002834
1	Transformer with Rectifier 3/ 6/ 9/ 12 V, 3 A (230 V, 50/60 Hz)	1003316 or
	Transformer with Rectifier 3/ 6/ 9/ 12 V, 3 A (115 V, 50/60 Hz)	1003315
1	Digital Multimeter P3340	1002785
1	Pair of Safety Experiment Leads, 75 cm	1002849
1	Pair of Safety Experimental Leads, 75cm, red/blue	1017718

Additionally recommended:

1	P-Doped Germanium on Printed Circuit Board	1009810
1	N-Doped Germanium on Printed Circuit Board	1009760
1	3B NETlog™ (230 V, 50/60 Hz)	1000540 or
	3B NETlog™ (115 V, 50/60 Hz)	1000539
1	3B NETlab™	1000544

BASIC PRINCIPLES

Electrical conductivity is highly dependent on the nature of the material. It is therefore common to classify materials according to their conductivity. Solid bodies for which conductivity only becomes measurable at relatively high temperatures are classified as semiconductors. The reason for this dependence on temperature is the band structure of the electron energy levels, which comprise a conduction band, a valence band and an intermediate zone, which in pure, undoped semiconductor materials cannot be occupied by electrons at all.

In the ground state, the valence band is the highest band occupied by electrons and the conduction band is the next band up, which is unoccupied. The separation between these bands is labelled E_g

and depends on the material itself. For germanium this quantity is approximately 0.7 eV. As the temperature increases, more and more electrons are thermally excited from the valence band into the conduction band, leaving behind "holes" in the valence itself. These holes move under the influence of an electric field E as if they were positive particles and contribute to the current much as electrons do (see Fig.1).

$$(1) \quad j = \sigma \cdot E$$

σ : Electrical conductivity of semiconductor material

Electrons and holes move with differing average drift velocities:

$$(2) \quad v_n = -\mu_n \cdot E \quad \text{and} \quad v_p = \mu_p \cdot E$$

μ_n : Mobility of electrons

μ_p : Mobility of holes

This ability to conduct which results from electrons being thermally excited from the valence band into the conduction band is called intrinsic conduction.

In a state of thermal equilibrium, the number of electrons in the conduction band is equal to the number of holes in the valence band, so that the current density in the case of intrinsic conduction can be written out as follows:

$$(3) \quad j_i = -e \cdot n_i \cdot v_n + e \cdot n_i \cdot v_p = e \cdot n_i \cdot (\mu_n + \mu_p) \cdot E ;$$

i.e. the intrinsic conductivity σ is

$$(4) \quad \sigma_i = e \cdot n_i \cdot (\mu_n + \mu_p) ,$$

The temperature dependence of the current carrier density n_i for electrons or holes is given by the following:

$$(5) \quad n_i = 2 \cdot \left(\frac{2\pi}{h^2} \cdot \sqrt{m_n m_p} \cdot kT \right)^{\frac{3}{2}} \cdot \exp\left(-\frac{E_g}{2kT}\right)$$

$$k = 8.617 \cdot 10^{-5} \frac{\text{eV}}{\text{K}} : \text{Boltzmann constant}$$

h : Planck's constant

m_n : Effective mass of electrons

m_p : Effective mass of holes

T : Sample temperature

The mobilities μ_n and μ_p also depend on temperature. In the temperature range above room temperature, the following applies:

$$(6) \quad \mu \sim T^{-\frac{3}{2}}$$

The dominant term with regard to temperature dependence, however, is the exponential expression. This means that the intrinsic conductivity at high temperature can be expressed in the following form:

$$(7) \quad \sigma_i = \sigma_0 \cdot \exp\left(-\frac{E_g}{2kT}\right) .$$

In this experiment to determine the conductivity of pure, undoped germanium, a constant current I is sent through the crystal and the voltage drop U is measured as a function of temperature. The conductivity σ can be calculated from the measured data thanks to the relationship

$$(8) \quad U = a \cdot E \quad \text{resp.} \quad I = b \cdot c \cdot j$$

a, b, c : dimensions of crystal

$$(9) \quad \sigma = \frac{I}{U} \cdot \frac{a}{b \cdot c}$$

EVALUATION

Equation (7) can be rewritten in the following form:

$$\ln \sigma = \ln \sigma_0 - E_g \cdot \frac{1}{2kT}$$

Therefore $y = \ln \sigma$ is plotted against $x = \frac{1}{2kT}$ and the band separation E_g

can be found from the gradient of the resulting straight line.

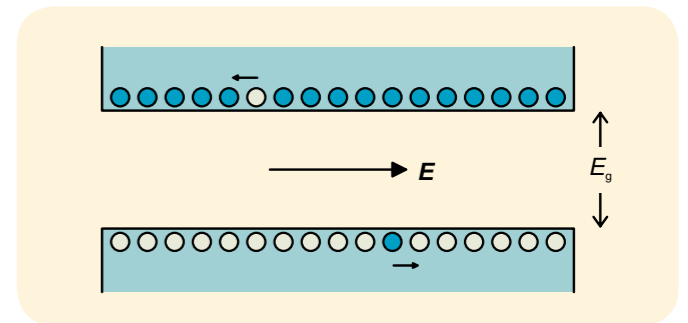

Fig. 1: Structure of semiconductor bands with one electron in the conduction band and a hole in the valence band, both of which drift due to the influence of an electric field E

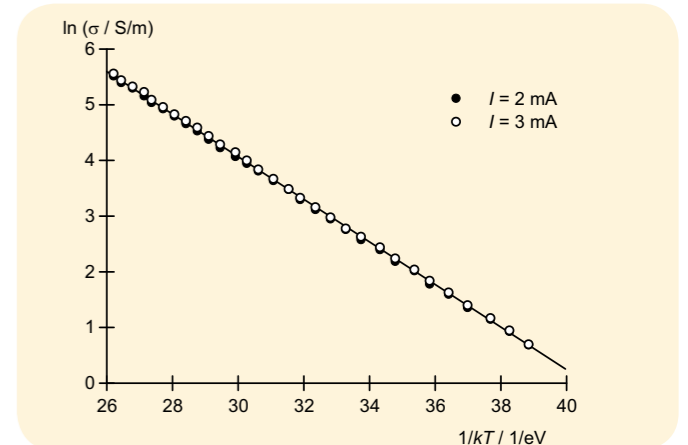

Fig. 2: Representation for the determination of band separation E_g in germanium

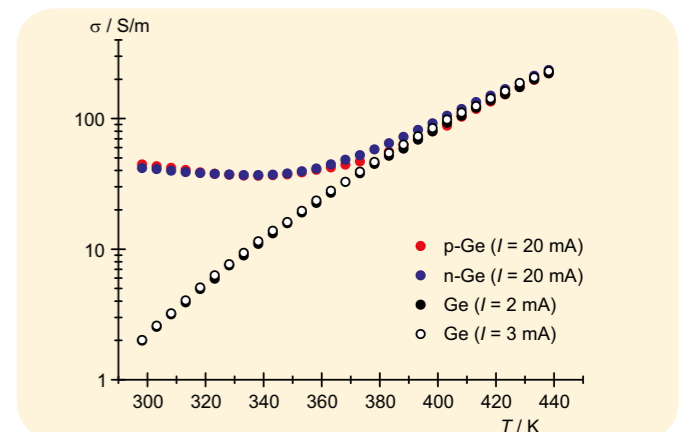

Fig. 4: Comparison between conductivities of pure and doped germanium



EXPERIMENT PROCEDURE

- Demonstrating the Hall effect in doped germanium.
- Measuring the Hall voltage as a function of the current and magnetic field at room temperature.
- Determining the sign, density and mobility of charge carriers at room temperature.
- Measuring the Hall voltage as a function of sample temperature.
- Determining the inversion temperature; differentiating between extrinsic and intrinsic conduction in the case of p-doped germanium.

NOTE

The temperature dependence of the electrical conductivity of the employed germanium crystals is investigated in experiment UE6020100.

3

OBJECTIVE

Investigating electrical conduction mechanisms in doped germanium with the Hall effect

SUMMARY

The Hall effect occurs in electrically conductive materials located in a magnetic field B . The Hall voltage's sign changes depending on whether the same current I is borne by positive or negative charge carriers. Its value depends on the charge carrier density. The Hall effect is consequently an important means of determining the mechanisms of charge transport in doped semiconductors. In this experiment, doped germanium crystals are examined at temperatures between 300 K and 450 K to ascertain the differences between electrical conduction enabled by doping, and intrinsic conduction enabled by thermal activation of electrons causing their transfer from the valence band into the conduction band.

REQUIRED APPARATUS

Quantity	Description	Number
1	Hall Effect Basic Apparatus	1009934
1	N-Doped Germanium on Printed Circuit Board	1009760
1	P-Doped Germanium on Printed Circuit Board	1009810
1	Magnetic Field Sensor ± 2000 mT	1009941
1	Coil D with 600 Taps	1000988
1	U Core	1000979
1	Pair of Pole Shoes and Clamping Brackets for Hall Effect	1009935
1	Transformer with Rectifier 3/ 6/ 9/ 12 V, 3 A (230 V, 50/60 Hz)	1003316 or
	Transformer with Rectifier 3/ 6/ 9/ 12 V, 3 A (115 V, 50/60 Hz)	1003315
1	DC Power Supply 0 – 20 V, 0 – 5 A (230 V, 50/60 Hz)	1003312 or
	DC Power Supply 0 – 20 V, 0 – 5 A (115 V, 50/60 Hz)	1003311
1	Digital Multimeter P3340	1002785
1	3B NET/log™ (230 V, 50/60 Hz)	1000540 or
	3B NET/log™ (115 V, 50/60 Hz)	1000539
1	Set of 15 Safety Experiment Leads, 75 cm	1002843
Additionally recommended:		
1	3B NET/lab™	1000544

BASIC PRINCIPLES

The Hall effect occurs in electrically conductive materials located in a magnetic field B . This effect is attributable to the Lorentz force which deflects the charge carriers producing an electric current I through a material sample perpendicularly with respect to the magnetic field and the current's direction. Charge separation results in an electric field E_H which is perpendicular to the current's direction and compensates the Lorentz force, while generating a Hall voltage U_H between the sample's edges. The Hall voltage's sign changes depending on whether the same current I is borne by positive or negative charge carriers. Its value depends on the charge carrier density. The Hall effect is consequently an important means of determining the mechanisms of charge transport in conductive materials, and used often to study doped semiconductors.

This experiment examines doped germanium crystals at temperatures between 300 K and 450 K. The crystals are present in the form of flat samples which have a length a , width b and thickness d , and which longitudinally conduct a current I . The magnetic field B pervades each sample perpendicularly with respect to the current. The resultant Hall voltage is:

$$(1) \quad U_H = R_H \cdot \frac{B \cdot I}{d}$$

The Hall coefficient is:

$$(2) \quad R_H = \frac{1}{e} \cdot \frac{n_p \cdot \mu_p^2 - n_n \cdot \mu_n^2}{(n_p \cdot \mu_p + n_n \cdot \mu_n)^2}$$

$e = 1.602 \cdot 10^{-19}$ ampere-second (elementary charge)

The densities n_n and n_p respectively of the electrons in the conduction band and electron holes in the valence band, as well as the mobilities μ_n and μ_p respectively of the electrons and corresponding holes are material quantities which depend on the sample temperature T .

Measured besides the Hall voltage in the experiment is the longitudinal voltage drop U in the sample in order to determine the electrical conductivity:

$$(3) \quad \sigma = e \cdot (n_n \cdot \mu_n + n_p \cdot \mu_p)$$

Also determined in this process is the Hall mobility:

$$(4) \quad \mu_H = R_H \cdot \sigma = \frac{n_p \cdot \mu_p^2 - n_n \cdot \mu_n^2}{n_p \cdot \mu_p + n_n \cdot \mu_n}$$

The charge carrier densities n_n and n_p are influenced by the doping, i.e. inclusion of foreign atoms in the crystal. In the case of p-doping, acceptor atoms bind electrons from the valence band and thereby produce electron holes in that band. In the case of n-doping, donor atoms each supply one electron to the conduction band.

The doped crystals are electrically neutral, i.e. their negative and positive charges cancel each other out. Accordingly:

$$(5) \quad \begin{aligned} n_n + n_A &= n_p + n_D \\ n_A: &\text{Concentration of acceptors} \\ n_D: &\text{Concentration of donors} \end{aligned}$$

Furthermore, n_n and n_p are coupled by a mass action law, the number of electron-hole pairs which form and recombine per unit of time being equal during temperature-dependent equilibrium. The following applies:

$$(6) \quad n_n \cdot n_p = n_i^2$$

n_i is the charge carrier density in the case of purely intrinsic conduction (see experiment UE6020100)

In general, therefore:

$$(7) \quad n_n = \sqrt{n_i^2 + \frac{(n_A - n_D)^2}{4}} + \frac{n_D - n_A}{2}$$

$$(8) \quad n_p = \sqrt{n_i^2 + \frac{(n_A - n_D)^2}{4}} - \frac{n_D - n_A}{2}$$

At room temperature, the concentrations n_A and n_D are significantly higher than the charge carrier density in the case of purely intrinsic conduction n_i . Consequently:

$$(9) \quad R_H = -\frac{1}{n_D \cdot e}, \quad \mu_H = -\mu_n$$

with n-doping at 300 K

$$(10) \quad R_H = \frac{1}{n_A \cdot e}, \quad \mu_H = \mu_p$$

with p-doping at 300 K.

The charge carriers' sign and density can therefore be read directly from the Hall coefficient. The charge carriers' mobility is equivalent to the Hall mobility.

EVALUATION

As more carriers become available for conducting electricity with increasing temperature, the Hall voltage decreases until it attains a value of zero.

In the case of p-doped germanium, the Hall voltage's sign changes because increasing intrinsic conduction leads to a dominant influence of the electrons whose mobility μ_n is higher. Electrical conduction enabled by doping dominates below the inversion temperature, while intrinsic conduction dominates above the inversion temperature.

At high temperatures, the n-doped and p-doped crystals are no longer distinguishable because:

$$n_n = n_p = n_i, \quad R_H = -\frac{1}{n_i \cdot e} \cdot \frac{\mu_n - \mu_p}{\mu_n + \mu_p}, \quad \mu_H = -(\mu_n - \mu_p)$$

The temperature dependence of the mobilities μ_n and μ_p is not evident in the Hall coefficient, because in both cases:

$$\mu \sim T^{-3/2} \quad (\text{also see experiment UE6020100})$$

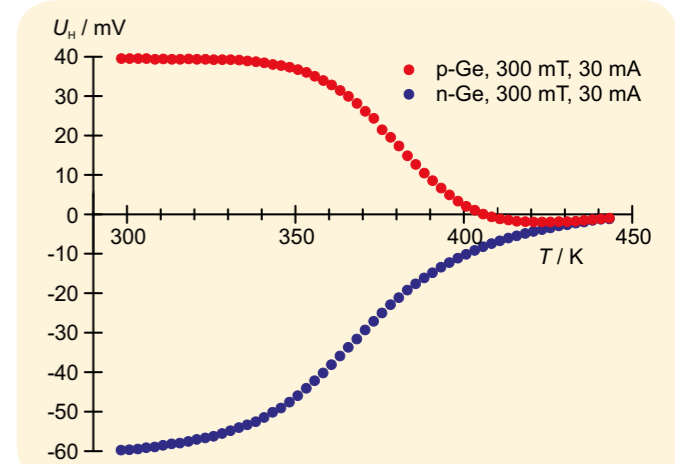

Fig. 1: Hall voltage in p- and n-doped germanium as a function of the temperature T

OBJECTIVE

Record characteristics for various thermocouples and determine their sensitivity

EXPERIMENT PROCEDURE

- Measure the thermocouple voltage U_{th} as a function of temperature T_1 and confirm that there is a linear relationship between for each of three different thermocouples.
- Determine the sensitivity S from the plots of U_{th} and T_1 .
- Estimate the reference temperature T_2 from the measured curves.

SUMMARY

If the ends of a metal wire are at different temperatures, since the thermally generated motions of the electrons have different velocities, thermal diffusion will occur between the hot and cold ends of the wire. The current resulting from this diffusion causes the cold end to be negatively charged with respect to the warmer end. The thermal diffusion voltage that arises is proportional to the difference in temperature between the two ends with the constant of proportionality being known as the Seebeck coefficient. If wires of two different metals are joined together, with contact points held at different temperatures, and a voltmeter is connected between the two unjoined ends, the result is a thermocouple. The voltmeter will then display a voltage which is directly proportional to the difference in temperature between the contact points. The experiment investigates this phenomenon with three different combinations of metals.

REQUIRED APPARATUS

Quantity	Description	Number
1	Set of 3 Thermocouples	1017904
1	Thermometer -20 – 110°C	1003384
1	Thermometer clip	1003528
1	Set of 10 Beakers, Tall Form	1002873
1	Magnetic Stirrer with Heater (230 V, 50/60 Hz)	1002807 or
	Magnetic Stirrer with Heater (115 V, 50/60 Hz)	1002806
1	Microvoltmeter (230 V, 50/60 Hz)	1001016 or
	Microvoltmeter (115 V, 50/60 Hz)	1001015

2
BASIC PRINCIPLES

If the ends of a metal wire are at different temperatures, since the thermally generated motions of the electrons have different velocities, thermal diffusion will occur. Since the thermal motion of electrons at the hot end is faster than that of those at the cooler end, more electrons on average move from the warm end to the cold end than the other way round. The current resulting from this diffusion causes the cold end to be negatively charged with respect to the warmer end resulting in a voltage between the two ends. This increasingly acts against the flow of electrons until the diffusion current ceases to flow.

The thermal diffusion voltage U_{td} is proportional to the difference in temperature $T_1 - T_2$ between the ends, with the constant of proportionality being known as the Seebeck coefficient k :

$$(1) \quad U_{td} = k \cdot (T_1 - T_2)$$

U_{td} : Thermal diffusion voltage,
 k : Seebeck coefficient,
 T_1 : Temperature at hot end
 T_2 : Temperature at cold end

If wires of two different metals are joined together, with contact points held at different temperatures, a thermoelectric current will result. The metal with the larger thermal diffusion voltage will determine the direction of the current flow. If a voltmeter is then connected between the ends, the result is a thermocouple. Due to the high input resistance, very little current will then flow and the voltmeter will indicate a voltage which is directly proportional to the difference in temperature between the contact points:

$$(2) \quad U_{th} = U_{td,B} - U_{td,A} = (k_B - k_A) \cdot (T_1 - T_2)$$

U_{th} : Thermocouple voltage,
 $U_{td,A}$, $U_{td,B}$: Thermal diffusion voltages for metals A and B
 k_A , k_B : Seebeck coefficients for metals A and B

Only the differential between the Seebeck coefficients

$$(3) \quad k_{BA} = k_B - k_A$$

which appears in equation (2) can be measured without difficulty. This corresponds to the sensitivity of a thermocouple consisting of metals A and B, given by the following:

$$(4) \quad S = \frac{dU_{th}}{dT_1}$$

It is common to use platinum, Pt, as the reference material, whereby the coefficients are given as K_{APt} .

This experiment involves measuring sensitivities S for three different pairs of metals. Water in a beaker will be heated to a temperature T_1 and one end of the thermocouple will be immersed in that. The other end of the thermocouple will be connected to a microvoltmeter in order to measure the voltage. The microvoltmeter sockets are at a constant temperature T_2 .

EVALUATION

The thermocouple voltage will be plotted against temperature in a graph of U_{th} against T_1 for each of the three thermocouples. A straight line is drawn to fit each set of points and the sensitivities of each element can then be determined from the gradients of the lines.

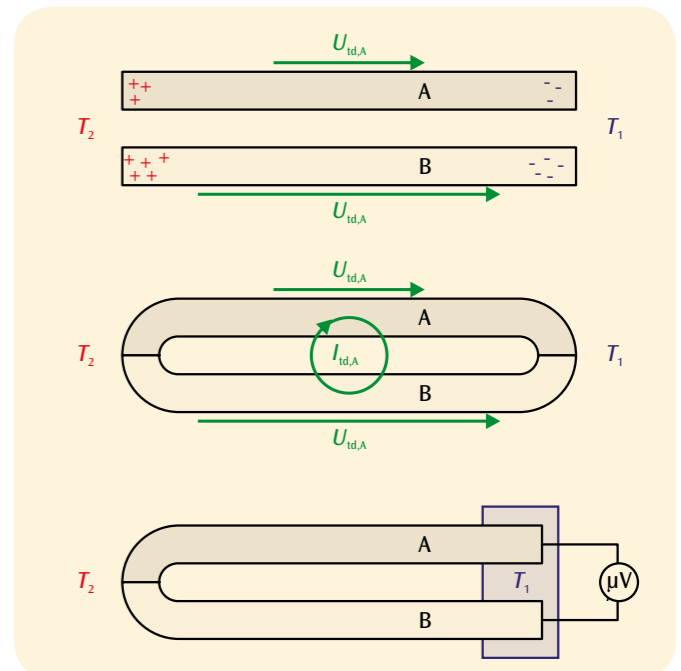

Fig. 1: Thermal diffusion in metal wires (top), thermoelectric current (centre) and thermocouple voltage in a loop made of two different metals (bottom)

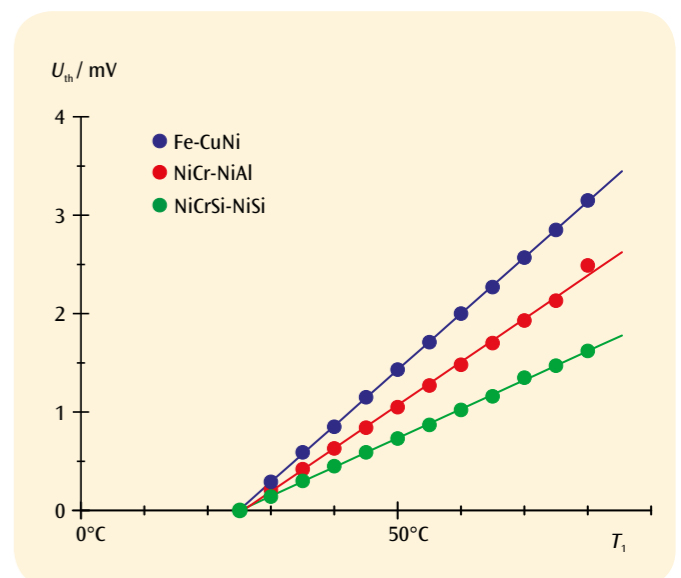

Fig. 2: Thermocouple voltages as a function of temperature for Fe-CuNi, NiCr-NiAl and NiCrSi-NiSi thermocouples. The measured curves cross the T_1 axis of the graph at the reference temperature $T_2 = 23^\circ\text{C}$

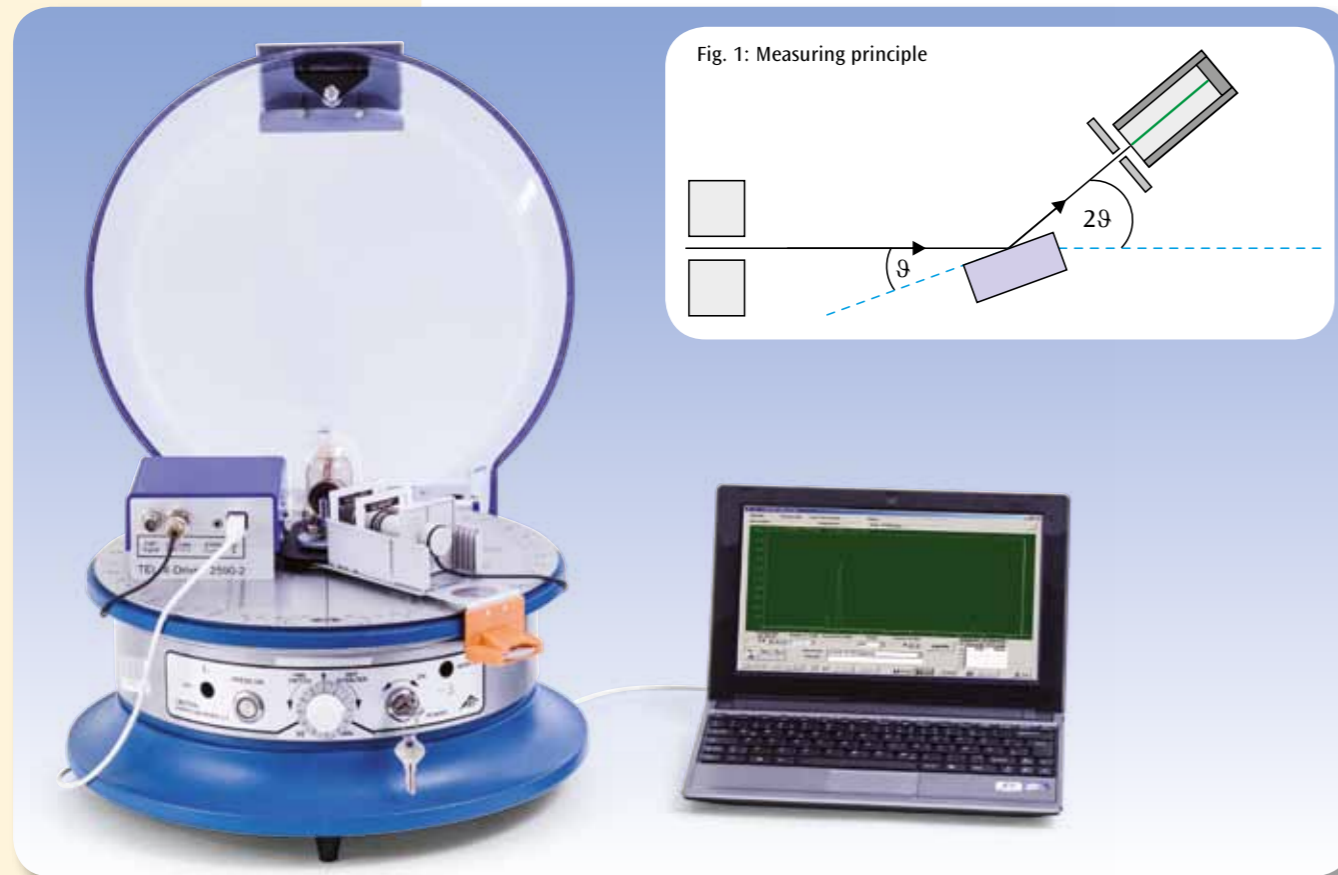
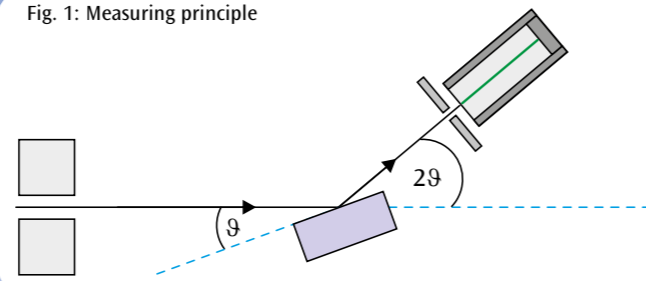

Fig. 1: Measuring principle



EXPERIMENT PROCEDURE

- Record diffraction spectra of the X-rays produced by a copper anode upon passing through crystals with a salt-like structure.
- Determine the lattice constants and make a comparison with the size of the crystals' components.

OBJECTIVE

Determine the lattice constants for crystals with a structure similar to salt (NaCl)

SUMMARY

Measurement of Bragg reflection is a key method for investigating monocrystals using X-rays. It involves X-rays being reflected by the various lattice planes, whereby the secondary waves reflected by individual layers undergo constructive interference when the Bragg condition is fulfilled. If the wavelength of the X-rays is known, it is possible to calculate the separation between lattice planes. In this experiment, various crystals which share the structure of salt (NaCl) are investigated and compared.

REQUIRED APPARATUS

Quantity	Description	Number
1	X-Ray Apparatus (230 V, 50/60 Hz)	1000657 or
	X-Ray Apparatus (115 V, 50/60 Hz)	1000660
1	Basic Set Bragg	1008508
1	Crystallography Accessories	1000666
1	Bragg Drive	1012871

2

BASIC PRINCIPLES

A key method for investigating monocrystals using X-rays was devised by H. W. and W. L. Bragg. They developed an interpretation of how atoms or ions were arrayed in a crystal which took the form of parallel layers in a structure containing the component atoms of the crystal lattice. Incoming plane waves of X-rays would then be reflected from these layers but the wavelength of the X-rays would remain unaffected.

The direction of the incident and reflected rays, parallel to the wave fronts, would be expected to meet the condition "angle of incidence = angle of reflection". The secondary waves reflected from the various lattice layers would also be expected to interfere with one another, whereby the interference would be constructive when the path difference between the secondary waves is an integer multiple of the wavelength λ .

The path difference can be deduced with the help of Fig. 1, where it can be seen that

$$(1) \quad \Delta = 2 \cdot d \cdot \sin \vartheta.$$

d : interplanar distance

ϑ : angle of incident and reflected rays

This means the condition for constructive interference is

$$(2) \quad 2 \cdot d \cdot \sin \vartheta_n = n \cdot \lambda.$$

Therefore, if monochromatic X-rays of known wavelength are used, the interplanar distance d can be found by measuring the angles.

In practice, this is done by turning the crystal by an angle ϑ with respect to the angle of incidence, while at the same time moving the Geiger-Müller detector by an angle of 2ϑ , see Fig. 2. Condition (2) is therefore precisely met when the Geiger counter registers maximum intensity.

This experiment uses the characteristic X-rays produced by an X-ray tube with a copper anode. This produces K_α radiation of wavelength $\lambda = 154 \text{ pm}$ and K_β radiation of wavelength $\lambda = 138 \text{ pm}$. Use of a nickel filter allows much of the K_β radiation to be suppressed, since the absorption edge of nickel lies between the two aforementioned wavelengths. In addition to their characteristic radiation, all X-ray tubes also emit "bremsstrahlung" (literally braking radiation) distributed over a continuous spectrum. This is evident as background beneath the peaks in the measured curves, which represent the characteristic lines.

This experiment investigates cubic monocrystals which have been sliced parallel to their (100) face. This makes the lattice planes which are relevant for Bragg reflection easy to identify. In order to improve the accuracy of the measurement, multiple orders of diffraction are considered.

The crystals provided include LiF and NaCl crystals. Supplementary measurements can also be made using KCl and RbCl crystals. All of these have the same crystal lattice structure, in which the two varieties of atom occupy alternating positions in the lattice. The interplanar distance d is therefore equal to half of the lattice constant a .

EVALUATION

Using equation (2) the following equation can be derived for determining the lattice constants:

$$a = 2 \cdot d = \lambda_{K\alpha} \cdot \frac{n}{\sin \vartheta_n}$$

A comparison between the values obtained for NaCl, KCl and RbCl indicates that the lattice constant correlates with the size of the alkali metal ions. The lattice constants for LiF and NaCl also differ because the component atoms of the crystal are of different sizes.

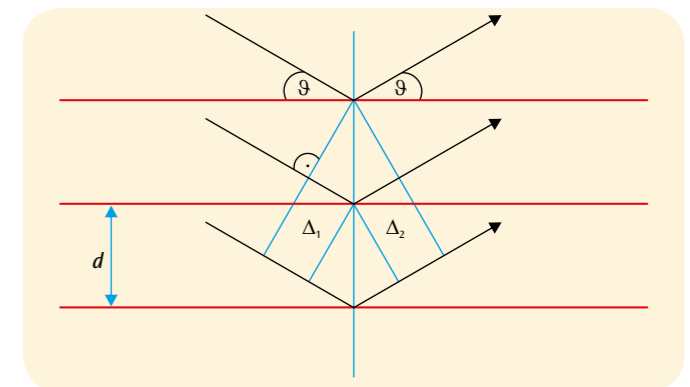

Fig. 2: Diagram showing derivation of Bragg condition

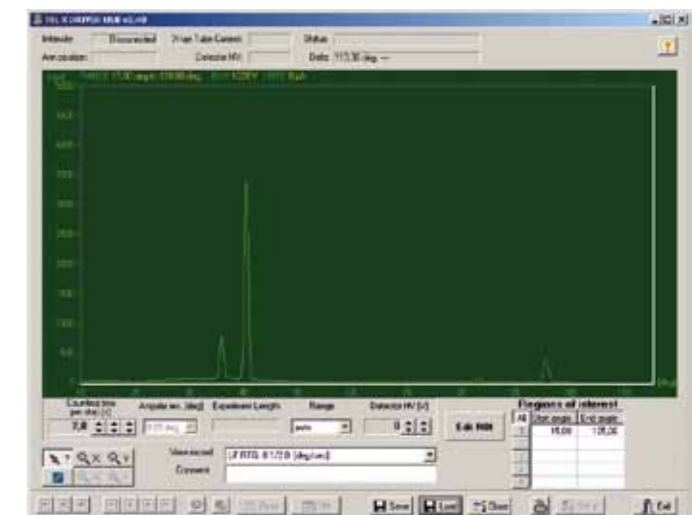

Fig. 3: Bragg curve for NaCl

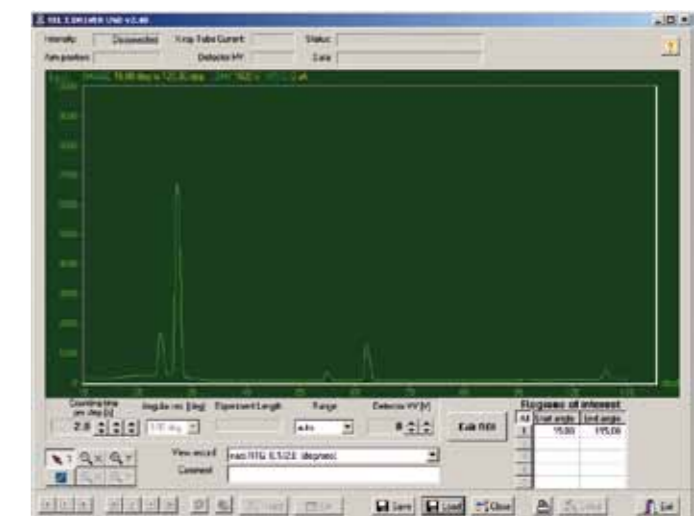
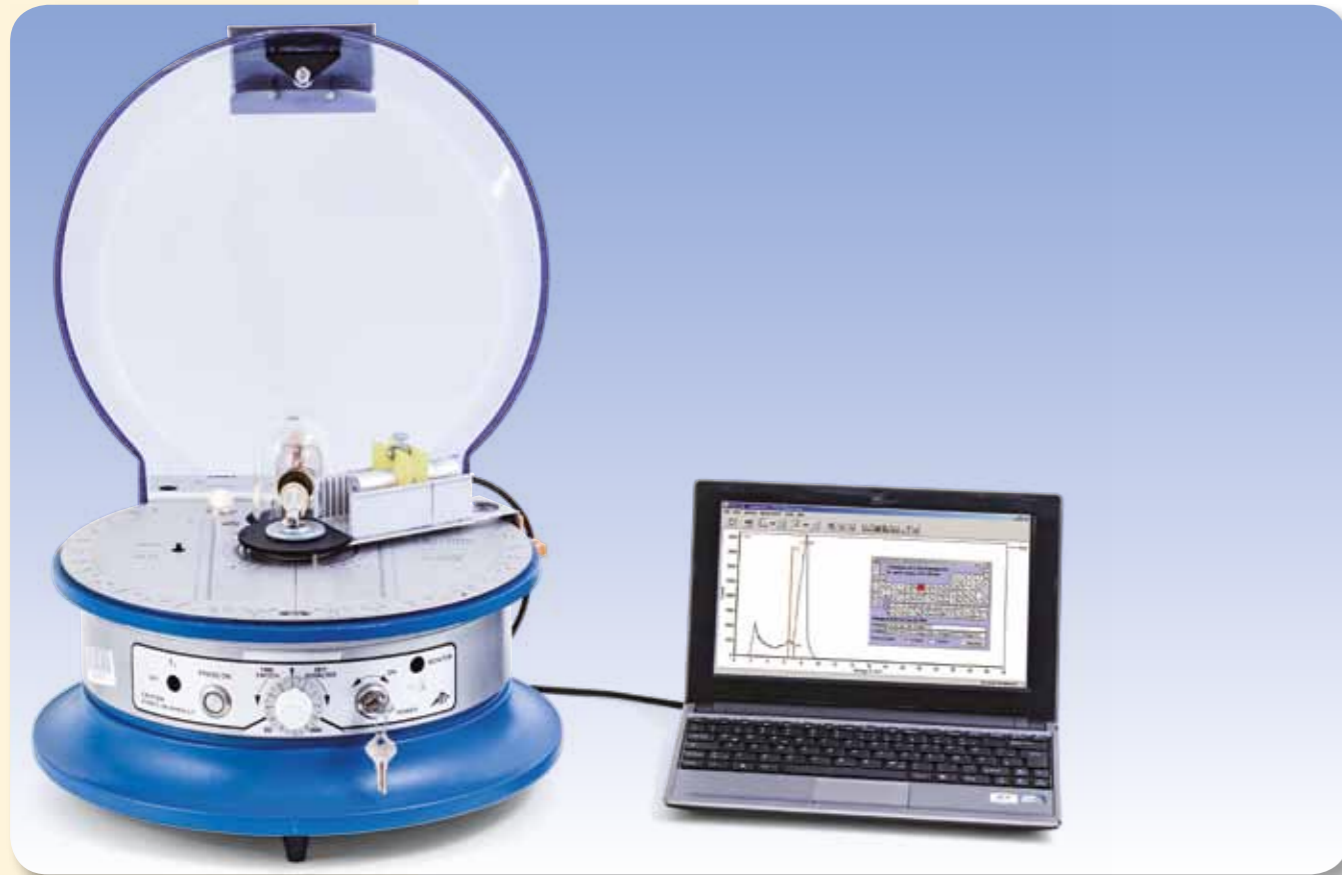

Fig. 4: Bragg curve for LiF



Fig. 5: NaCl crystal



EXPERIMENT PROCEDURE

- Record X-ray fluorescence spectra for various material samples.
- Identify the chemical components on the basis of characteristic X-ray lines.

OBJECTIVE

Non-destructive analysis of chemical composition

SUMMARY

Chemical elements can be uniquely identified on the basis of their characteristic X-ray radiation. This is because the energy of that radiation is dependent on the atomic number of the element. X-ray fluorescence analysis involves exciting this characteristic X-ray radiation by bombarding the material to be investigated with highly energetic X-ray quanta. This experiment analyses the chemical composition of multiple material samples. Comparisons are made between wrought iron and stainless steel, copper, brass and bronze, as well as a variety of coins.

REQUIRED APPARATUS

Quantity	Description	Number
1	X-Ray Apparatus (230 V, 50/60 Hz)	1000657 or
	X-Ray Apparatus (115 V, 50/60 Hz)	1000660
1	Basic Set Bragg	1008508
1	X-Ray Energy Detector	1008629
1	Set of Fluorescence Samples	1012868
Additionally recommended:		
	Coins	



BASIC PRINCIPLES

Chemical elements can be uniquely identified on the basis of their characteristic X-ray radiation. This is because the energy of that radiation is dependent on the atomic number of the element. This means that the chemical composition of a material can be determined by measuring the characteristic X-ray radiation. Chemical bonds between the elements are not relevant to this since they do not involve the inner shells of atoms where X-ray transitions occur.

X-ray fluorescence analysis involves exciting this characteristic X-ray radiation by bombarding the material to be investigated with highly energetic X-ray quanta. The excitation energy needs to be higher than the characteristic radiation to be expected, meaning that it may not be possible to excite high-order transitions in the K series of elements. The analysis therefore needs to concentrate on transitions in the L series, see Fig. 1.

An X-ray energy detector is provided for this experiment in order to record the energy spectra. The incident X-ray radiation causes interactions between electron/hole pairs in the atoms of crystals forming a silicon PIN photodiode. The overall charge associated with these is proportional to the X-ray energy. The charge is converted into a voltage pulse proportional to the X-ray energy which can then be transmitted to a computer as a digital value. Evaluation software is used to plot the distribution of pulses of specific amplitude. When the energy is calibrated, this distribution is equivalent to the energy spectrum we are seeking.

This experiment uses an X-ray tube with a copper anode as its source of radiation. The chemical composition of multiple material samples are analysed and comparisons made between wrought iron and stainless steel, copper, brass and bronze, as well as a variety of coins.

EVALUATION

The evaluation software allows the measured energy levels to be compared with values quoted in literature for the characteristic radiation wavelengths of the materials in question.

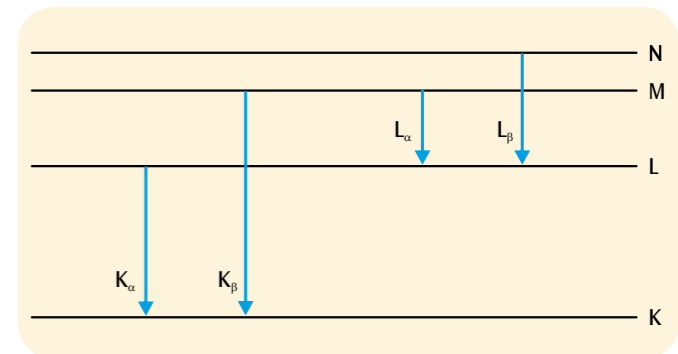

Fig. 1: Simplified energy band diagram for an atom with characteristic X-ray lines

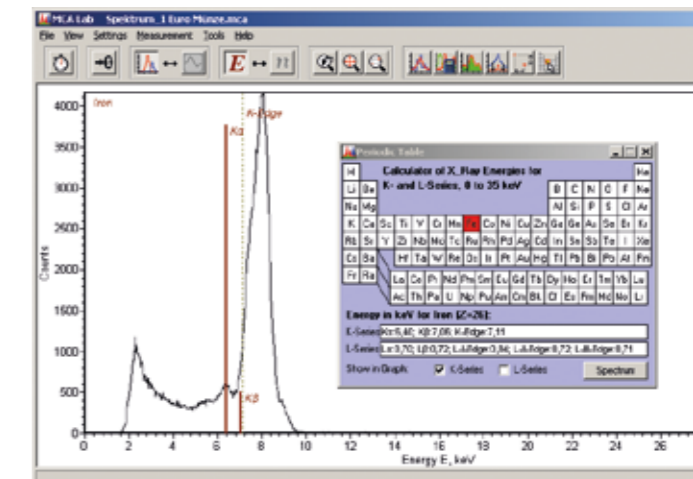

Fig. 2: X-ray fluorescence spectrum for a one euro coin

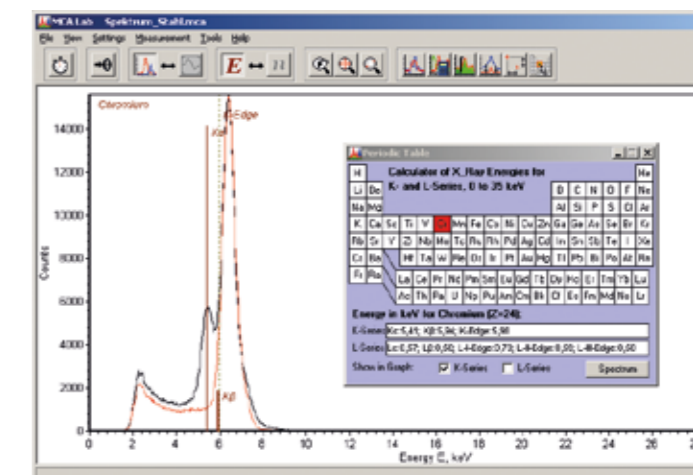

Fig. 3: X-ray fluorescence spectra for wrought iron (red) and stainless steel (black)

STUDENT EXPERIMENT KIT SYSTEM

SEK – ULTRASONIC WAVES

Large equipment set incorporating 30 student experiments for demonstrating the fundamental properties of waves using the example of 40 kHz ultrasonic waves. Stored in a tough Gratnell tray with foam inlay featuring recesses moulded to the shape of the apparatus and covered by a transparent lid. Includes CD with experiment instructions. Includes two ultrasonic transmitters, a rod-shaped microphonic sensor for recording and analysing oscillations using a standard oscilloscope and an ultrasonic pen for recording wave fronts along the desktop in the form of lines of the same phase (isophases). Many of the experiments can also be carried out without using an oscilloscope. In order to measure ultrasonic amplitudes, it is sufficient in many cases to use an analogue voltmeter for alternating current if it has a wide enough frequency range.

1016651 (230 V, 50/60 Hz)

1014529 (115 V, 50/60 Hz)

Includes:

- 1 Ultrasonic control unit
- 2 Ultrasonic transmitters, 40 kHz
- 1 Ultrasonic pen
- 1 Holder for ultrasonic pen
- 1 Holder base for ultrasonic pen
- 1 Microphone probe
- 2 Beam splitters
- 3 Clamps for beam splitters
- 1 Fresnel zone plate
- 1 Concave mirrors
- 2 Side pieces for double slit/reflectors
- 1 Centre post for double slit
- 1 Clap for double slit
- 1 Ultrasonic absorber
- 2 BNC cables, 1 m
- 1 Cable, BNC/4-mm
- 1 Plug-in power supply



CD contains
experiment
instructions

Includes Instructions for 30 Experiments on Ultrasonic Waves

- Display of sound oscillations on an oscilloscope *)
- Relationship between oscillations and waves *)
- Comparison of oscillations at two points along a wave *)
- Analysis of phase relationships using an ultrasonic "pen" *)
- Determination of wavelength and velocity of sound
- How velocity of sound depends on temperature
- Transmission characteristic of ultrasonic transmitters **)
- Resonance curve for ultrasonic transducers *)
- Transmission and reflection of ultrasonic waves **)
- Absorption of ultrasonic waves **)
- Superimposition of sinusoidal oscillations *)
- Constructive and destructive reinforcement when sinusoidal oscillations are superimposed *)
- Recording of wave fronts using ultrasonic pen
- Generation and detection of straight wave fronts
- Diffraction of ultrasonic waves by an edge
- Diffraction of ultrasonic waves by a single slit
- Interference between two beams **)
- Law of reciprocity for interference between two beams **)
- Diffraction by a double slit **)
- Phase relationships for diffraction by a double slit I *)
- Phase relationships for diffraction by a double slit I **)
- Formation of images by a spherical concave mirror **)
- Plotting of Fresnel zones **)
- Formation of images by a Fresnel zone plate **)
- Interference of ultrasonic waves by Lloyd's mirror **)
- Design of a simple interferometer **)
- Design of a Michelson interferometer **)
- Elimination of interference by interrupting the path *)
- Generation of standing ultrasonic waves **)
- Beats in ultrasonic waves *)
- Doppler effect in ultrasonic waves

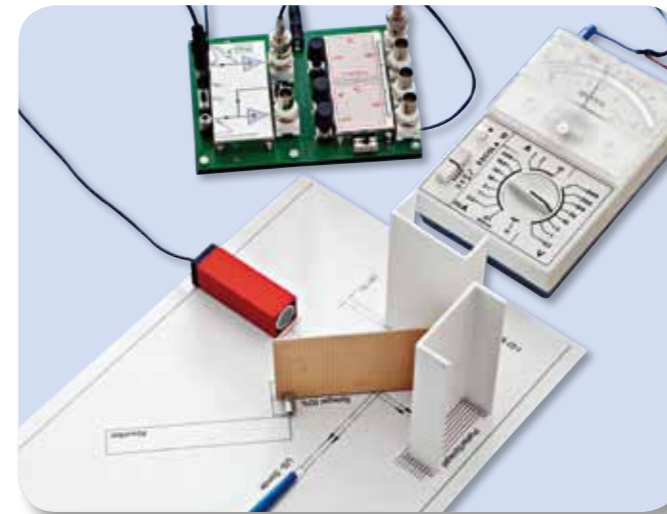

Michelson Interferometer

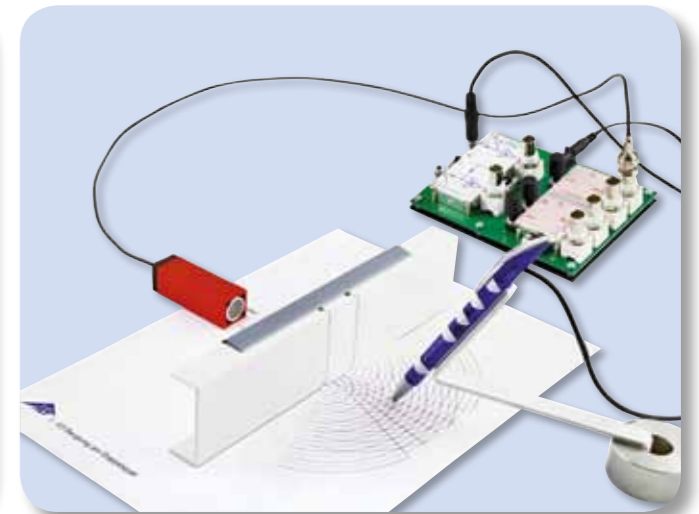

Diffraction by a double slit

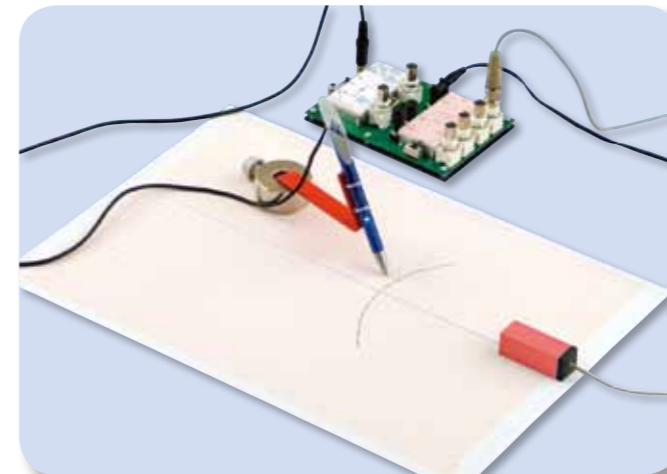

Recording of wave front

Additionally required:

1017264 Dual-Channel Oscilloscope (for experiments marked *)

1006811 Multimeter ESCOLA 2 (for experiments marked **)

Please ask for
quantity discounts
on class sets of
8 pieces or more.

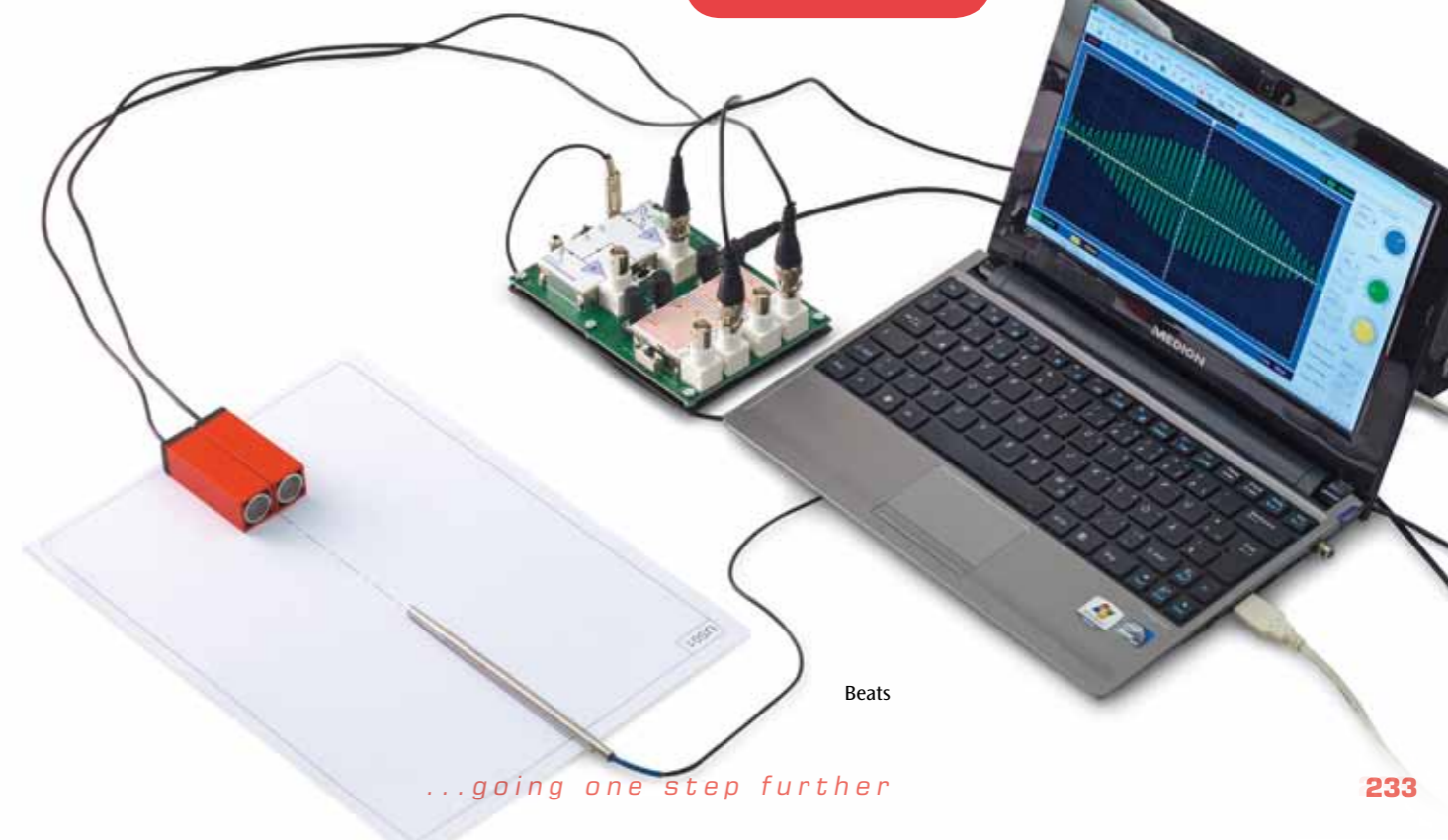

Beats

...going one step further

KRÖNCKE OPTICAL SYSTEM FOR STUDENT EXERCISES

BASIC SET FOR KRÖNCKE OPTICAL SYSTEM

The Kröncke optical system provides robust reliability that has been tried and tested for decades and offers all the precision needed for student exercises and practical courses in numerous experiments on ray and wave optics. The experiments are carried out in traditional fashion using the white light of an incandescent lamp, the filament of which can be projected through an adjustable slit to observe interference in particular. All optical components are mounted in diaphragms with no stems and can easily be adjusted vertically and with precision into the optical light path when mounted on optical riders. Optical riders can freely move on the U-profile rail of an optical bench and can be attached with a minimum of force.

Contents:

- 1 Optical lamp
- 1 Transformer 12 V, 25 VA
- 1 Optical bench, 1000 mm
- 6 Optical slides
- 2 Clamps
- 2 Converging lenses, $f = 50$ mm
- 2 Converging lenses, $f = 100$ mm
- 2 Converging lenses, $f = 150$ mm
- 1 Converging lens, $f = 300$ mm
- 1 Converging lens, $f = 500$ mm
- 1 Diverging lens, $f = -100$ mm
- 1 Diverging lens, $f = -500$ mm
- 1 Diaphragm with 1 slit
- 1 Diaphragm with 3 slits
- 1 Photograph in slide frame
- 1 Transparent screen
- 1 White screen
- 1 Set of 4 colour filters
- 1 Ruler, 15 mm
- 1 Set of holes arranged to form the number "1"
- 1 Pinhole aperture, $d = 1$ mm
- 1 Pinhole aperture, $d = 6$ mm
- 1009932** (230 V, 50/60 Hz)
- 1009931** (115 V, 50/60 Hz)

CD contains
all experiment
instructions



RAY OPTICS:

- Pinhole camera
- Imaging with converging lenses
- Image aberrations
- Images in the eye (eye model)
- Correction of vision
- Magnifying glasses
- Microscopes
- Astronomical telescopes
- Terrestrial telescopes
- Slide projectors

Equipment ray optics:

- 1009932** Basic Set for Kröncke Optical System (230 V, 50/60 Hz)
- or
- 1009931** Basic Set for Kröncke Optical System (115 V, 50/60 Hz)



POLARISATION:

- Polarisation of transverse waves
- Polariser and analyser
- Visibility of polarised light in turbid water
- Double refraction
- Rotation of planes of polarisation by a sugar solution

Equipment polarisation:

- 1009932** Basic Set for Kröncke Optical System (230 V, 50/60 Hz)
- or
- 1009931** Basic Set for Kröncke Optical System (115 V, 50/60 Hz)
- 1009701** Supplementary Set for Polarisation



Supplementary Set for Polarisation

Supplementary set to the Kröncke optics basic set (1009932 resp. 1009931) for carrying out student experiments on the polarisation of light waves.

Contents:

- 1 Pair of polarising filters
- 1 Pinhole aperture, 10 mm
- 1 Rectangular cuvette
- 1009701**



INTERFERENCES:

- Fresnel mirror
- Diffraction by small openings and plates
- Diffraction by an air gap
- Diffraction by the wire
- Diffraction by multiple slits
- Diffraction by the grating
- Optical resolution
- Determining the wavelength of light

Equipment interference:

- 1009932** Basic Set for Kröncke Optical System (230 V, 50/60 Hz)
- or
- 1009931** Basic Set for Kröncke Optical System (115 V, 50/60 Hz)
- 1009700** Supplementary Set for Interference



2m

Diffraction by a multiple slit



Please ask for
quantity discounts
on class sets of
8 pieces or more.

Supplementary Set for Interference

Supplementary set to the Kröncke optics basic set (1009932 resp. 1009931) for carrying out student experiments on the interference of light waves.

Contents:

- 1 Optical bench, 500 mm
- 1 Adjustable slit
- 1 Diaphragm with 9 circular discs
- 1 Diaphragm with 9 circular holes
- 1 Diaphragm with 3 individual slits and 1 double slit
- 1 Diaphragm with 4 multiple slits and grating
- 1 Diaphragm with 3 ruled gratings
- 1 Micrometer screw
- 1 Fresnel mirror
- 1009700**

MODELS FOR BIOLOGY TEACHING



DNA Extraction from Onion

With this easy test on the theme of cellular biology and genetics, you can isolate chromosomal DNA from an onion without a long preparation time, during a class. Your students will learn thanks to this experiment about the basic process of DNA extraction. Everything is included in the kit so that 5 groups can work at the same time. This effective classroom experiment with a high DNA yield will provide enjoyment for your students.

Contents for 15 experiments:

80 ml extraction buffer, 500 mg protease mix, 15 flat-bottomed tubes, 15 round paper filters, 5 funnels, 15 wooden picks, experiment instructions (multilingual).

Dimensions: 20.5x20.5x10.5 cm

Weight: 534 g

1010264



Monocular Course Microscope Model 300 (230 V, 50/60 Hz)

The model 300 course microscope meets all the requirements for high-quality biology lessons. It is characterised by its ease of use and its fine mechanical and optical qualities. It is equipped with an object stage, 4-objective revolver with DIN achromatic objectives featuring 4x, 10x, 40x, 100x magnification and an Abbe condenser.

1003271



Dissecting instruments

This first-rate dissecting set contains top-quality stainless steel instruments in an attractive vinyl case.

- 1 pair of scissors, pointed, 10 cm
- 1 pair of forceps, pointed, 13 cm
- 1 dissecting needle, 13.5 cm
- 1 scalpel blade holder n° 4
- 5 replacement scalpel blades n° 11

18x8x3 cm, 0,15 kg

1008710



The Plant Cell

magnified 500,000-1,000,000 times

The two-piece model presents the structure of a typical plant cell with cytoplasm and cell organelles, as viewed from an electron microscope. For better illustration, all important organelles are raised and displayed in colour, e.g.:

- Cell wall
- Cell membrane
- Nucleus
- Smooth Endoplasmic Reticulum
- Rough Endoplasmic Reticulum
- Ribosomes
- Chloroplasts
- Mitochondria
- Dictyosomes/Golgi apparatus

20x14x32 cm; 0.8 kg

1000524

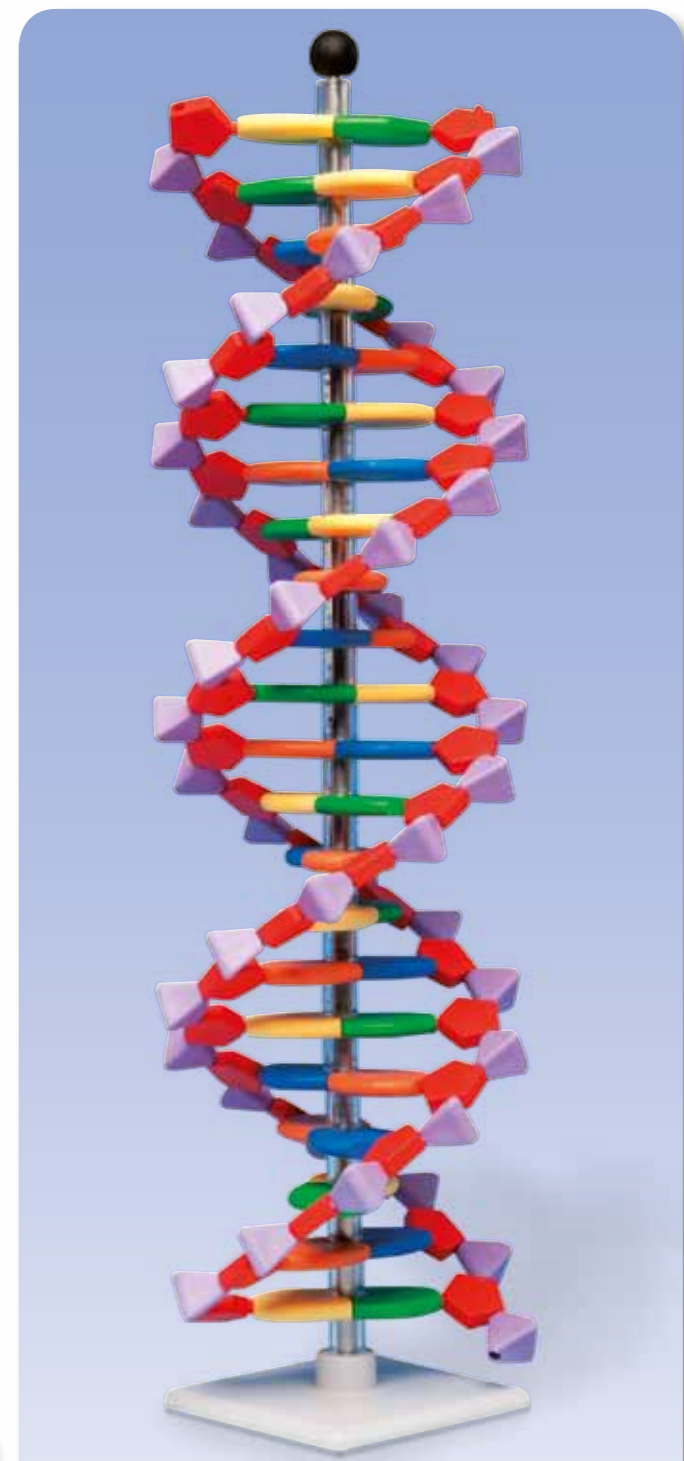

miniDNA™ 22 Layer Molecular Model

The miniDNA™ system comprises abstract shaped colour coded parts to represent the nitrogenous bases, pentagonal sugar and pyramidal phosphate parts required to make the Double helix model of DNA. Contents: 11 Thymine (orange), 11 Adenine (blue) 11 Guanine (green), 11 Cytosine (yellow), 44 Deoxyribose (red), 44 Phosphate (purple) Supplied with assembly instructions and its own stand. Packed in a plastic box. 44 cm; diam 11 cm

1005297

MODELS FOR BIOLOGY TEACHING

The Life of the Honeybee – Apis cerana
 These vividly illustrative embedded specimens give your students an excellent insight into the world of the honeybee. Included are high quality specimens of 1. Egg, 2. Larva, 3. Pupa, 4 Adult (Worker), 5 Adult (Drone), 6. Adult (Queen), 7. The Base of Nest, 8. Worker Comb, 9. Queen Comb, 10. Bee Pollen, 11. Honey, 12. Wax.

165x80x25 mm; 150 g
1005971



Cherry Blossom with Fruit (Prunus Avium)
 This model shows the blossom of the sweet cherry (3-parts) enlarged 7 times as well as a cherry fruit enlarged 3 times. The cherry blossom can be split into two halves to reveal the removable ovary with style and stigma.

32,5 cm; 0,6 kg
1000530



Fire Salamander (Salamandra salamandra)
 A salamander which will be particularly loved by younger students. The fire salamander is painted with stunning realism and its identifying characteristics are clear to see. It is a life-size facsimile modelled on natural background.

1001267

Eye, 5 times full size, 6-part
 This model dissects into:

- Both halves of sclera with cornea and eye muscle attachments
- Both halves of the choroid with iris and retina
- Lens
- Vitreous humour

On base. 9x9x15 cm; 0.1 kg
1000259



Mini Torso, 12-part
 This torso is approximately half life size. Even small hands can quickly disassemble it, removing:

- 2-head halves
- Brain half
- 2 lungs
- 2-part heart
- Stomach
- Liver with gall bladder
- 2-part intestinal tract

54x24x18 cm; 1,89 kg
1000195

Pressure equalisation in the middle ear
 This functional model shows the pressure equalising mechanism of the middle ear via the auditory tube. Bulging out or denting in of the eardrum and the subsequent equalisation of the pressure are demonstrated. Delivered with replacement membrane and teachers' manual.

16x13x12 cm, 0,2 kg
1012829

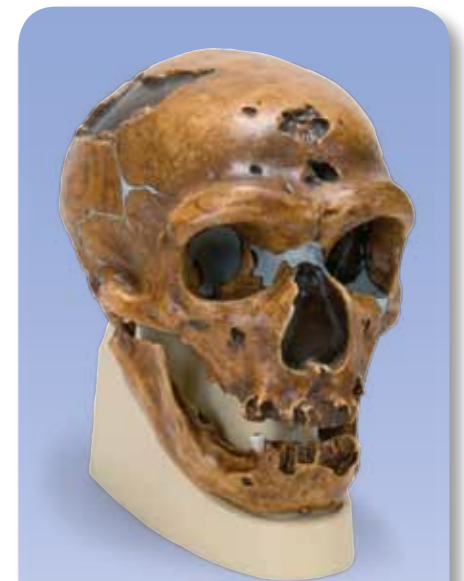
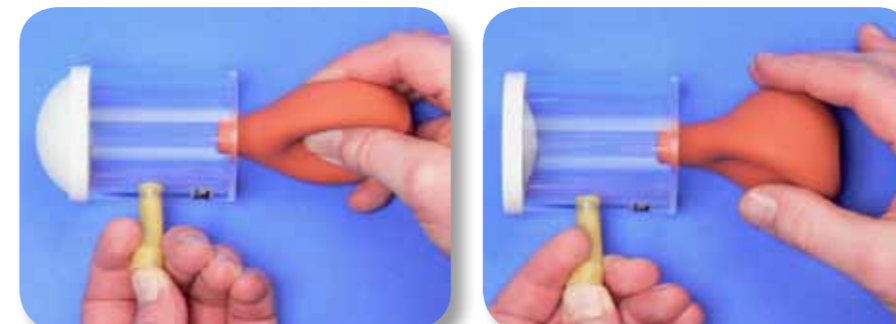

Anthropological Skull – La Chapelle-aux-Saints
 Cast from a reconstruction of the La Chapelle-aux-Saints skull, the model skull is an accurate copy of one belonging to a 50-55 year old male Neanderthal from ancient Europe of the species Homo (sapiens) neanderthalensis. Early man. Discovered in southern France
 Discovery: 1908; Age: Approximately 35,000 to 45,000 years.

22x16x22.5 cm; 0.9 kg
1001294

PLATE TECTONICS AND VOLCANISM

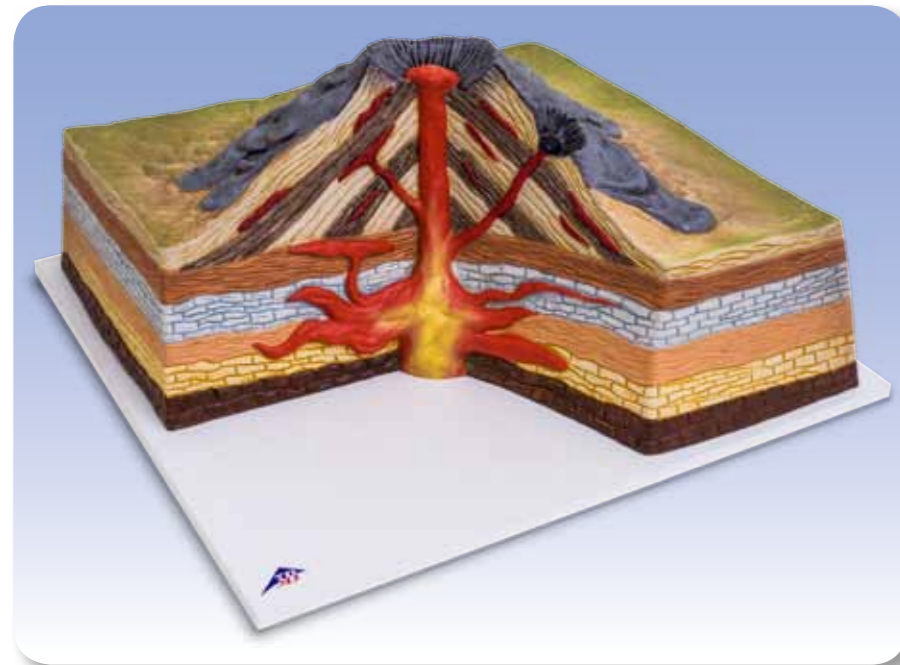

Stratovolcano
This hand-painted model of a stratovolcano with a section removed shows the path of liquid magma through the earth's interior to the exterior.

Material: PVC
Dimensions: 47x35x19 cm
Weight: 2.40 kg
1017595



Set of three volcanic rocks
Set of three vulcanite rocks consisting of three little bags, each containing ten walnut-sized pieces of lava rock, obsidian and pumice stone.
1018462

Mid-Atlantic Ridge
This model shows the S-shaped course in 3D of the volcanic mountain range produced by tectonic shifts in the Atlantic Ocean.

Size at the equator: 1:32x106
Material: PVC
Dimensions: 64x48x8 cm
Weight: 6.5 kg
1017594

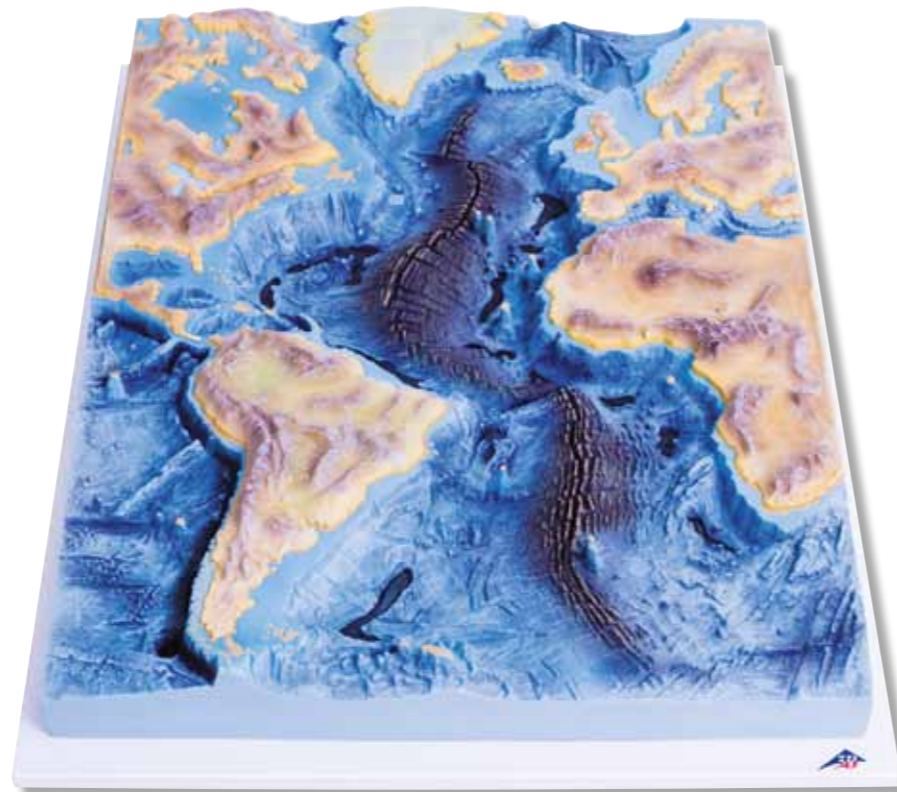

COLLECTIONS OF STONES



COLLECTION OF 24 ROCKS

The collections contain 24 frequently-occurring examples of various stone and mineral groups. The examples are approx. 3x3x3 cm³ to 5x5x5 cm³ in size, and come in a robust box that includes numbering, labels and information booklet.



Collection of 24 volcanic rocks and minerals
The collection contains volcanic rocks and minerals

Volcanic rocks: basalt, phonolite, pitchstone, rhyolite
Lava: Lava from Vesuvius, basaltic lava and rhyolitic lava
Pyroclasts: lapilli, volcanic ash, pumice stone
Minerals: anorthite, anorthoclase, augite, cristobalite, hauyne, leucite, natrolite, nepheline, pickeringite, sanidine, sulphur, thaumasite, tridymite, obsidian
1018442

Collection of 24 rocks
The collection contains frequently occurring examples of metamorphic, sedimentary and magmatic rocks as well as important examples of industrial rocks.

Magmatic rocks, plutonites: foyaitite, gabbro, granite, granodiorite, larvikite and monzonite
Magmatic rocks, vulcanites: basalt, pumice stone, phonolite, rhyolite
Sedimentary rocks: breccia, dolomite, gypsum, limestone, chalk, quartzite and sandstone
Metamorphic rocks: amphibolite, eclogite, mica schist, gneiss, marble, phyllite and serpentinite
1018443

Collection of 24 minerals
The collection contains examples of ten classes of minerals: elements, sulphides, halogenides, oxides, carbonates, borates, sulphates, silicates, phosphates and organic compounds.

1. **Elements:** graphite and sulphur
2. **Sulphides:** bournonite, galenite and pyrite
3. **Halogenides:** fluorite and halite
4. **Oxides:** hematite, quartz and rutile
5. **Carbonates:** calcite and dolomite
6. **Borates:** ludwigite
7. **Sulphates:** barite, coelestine and gypsum
8. **Phosphates, arsenates and vanadates:** apatite and vanadite
9. **Silicates and germanates:** actinolite, amazonite, muscovite, sodalite and talc
10. **Organic compound:** copal
1018444

3B SCIENTIFIC PHYSICS PRODUCTION IN GERMANY, KLINGENTHAL

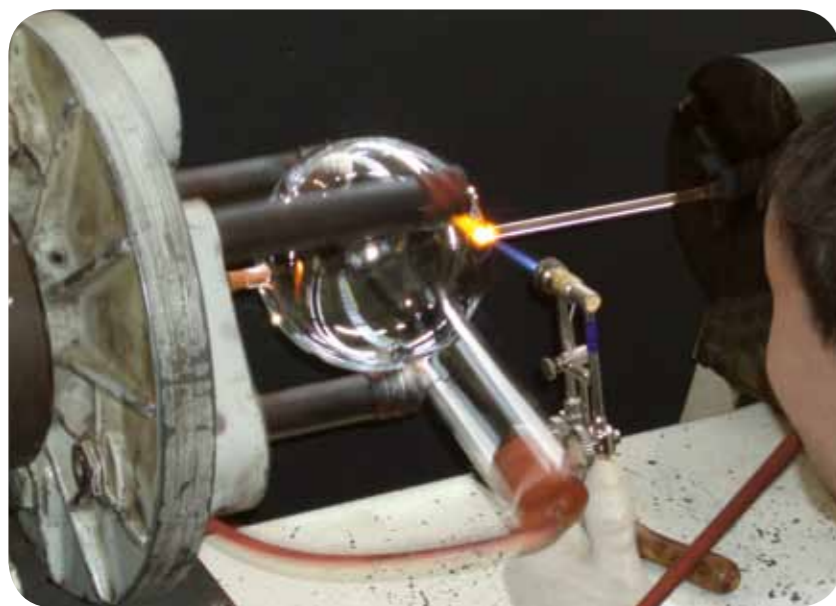

Manufacturing a TELTRON® electron tube at 3B Scientific in Germany

Electron tubes are produced at only a very small number of places in the world. Only specially trained technicians with many years of experience have the skills that are needed for this technologically advanced manufacturing process, which ensures that every TELTRON® electron tube that you receive from us will have the same consistently high quality.



Assembly production at the CNC Processing Centre

The universally recognised high quality of the teaching equipment produced is achieved through a combination of modern process technology with the best traditional craftsmanship. The skills and facilities of the CNC Processing Centre in Klingenthal guarantee not only the mechanical precision that is essential for high-quality physical instruments, but also cost-effective series production with consistently high quality.



A CAD/CAM workstation

A direct extension from the principles of CAD (Computer Aided Design) is CAM (Computer Aided Manufacturing), here shown being applied to controlling a flat-bed milling machine. This manufacturing technology makes it possible to fulfil special project requirements with speed and with the usual high precision.

3B SCIENTIFIC HISTORY



The international 3B Scientific group of companies is the world's largest and most experienced manufacturer of anatomical teaching aids. The oldest production site was set up as early as 1819 in Budapest, Hungary. The continuously growing success of 3B Scientific is the result of global expansion, based on the production and sales of high-quality medical and scientific teaching aids available at fair prices. The internationally registered brand name 3B Scientific® can be found around the world in the fields of natural sciences, medical training and patient education. The product range includes products for lectures in physics and biology as well as anatomical models, software and charts, medical simulators, acupuncture and other therapy products. The company has been awarded the DIN EN ISO 9001 certification for the excellent quality of its services, products and organizational structures. This official step towards quality management emphasizes the continuing process of innovation, product improvement and customer orientation that is associated with the brand name 3B Scientific®.



- 1819 Calderoni founded in Budapest, Hungary
- 1912 Training Workshops of the German Hygiene Museum founded in Dresden
- 1948 Paul Binhold Lehrmittelfabrik founded in Hamburg
- 1950 Production of the first plastic skeleton
- 1952 First skeleton manufacturing plant opened
- 1963 New headquarters at Rudorffweg, Hamburg
- 1965 Introduction of the Torso product line
- 1970 Introduction of the Binhold company logo
- 1979 Anatomical models first exported to the USA
- 1983 First manufacturing of injection moulded skeleton parts
- 1986 Care simulators added to the product range
- 1988 Anatomical models first exported to Japan
- 1991 DHM Lehrmittelfabrik GmbH founded in Dresden
- 1993 Acquisition of Calderoni and foundation of Biocalderoni in Hungary
- 1995 American 3B Scientific founded in Atlanta, USA
- 1996 New logo for the 3B Scientific Group
- 1997 Nihon 3B Scientific founded in Niigata, Japan
- 1998 France 3B Scientific founded in Bartenheim, France
- 1998 Merger of Paul Binhold Lehrmittelfabrik GmbH and DHM Lehrmittelfabrik to form 3B Scientific GmbH
- 1999 China 3B Scientific founded in Suzhou, China
- 2000 DIN EN ISO 9001 certification
- 2001 Introduction of the full 3B Scientific® product range for physics
- 2002 Italy 3B Scientific founded in Bologna, Italy
- 2003 España 3B Scientific founded in Valencia, Spain
- 2003 UK 3B Scientific founded in Weston-super-Mare, United Kingdom
- 2004 All-European distributor of SEIRIN® acupuncture needles
- 2004 Acquisition of ELWE Didactic GmbH in Klingenthal
- 2005 Acquisition of TELTRON® brand name and production
- 2005 Russia 3B Scientific founded in St. Petersburg.
- 2006 Brasil 3B Scientific founded in Joinville, Brasil.
- 2007 Thai 3B Scientific Co Ltd., founded in Bangkok, Thailand
- 2009 DIN EN ISO 9001 certification
- 2011 Implementation of SAP as business controlling software
- 2012 Korea 3B Scientific, founded in Yongin, South Korea
- 2012 3B Scientific TR, founded in Istanbul, Turkey



FRANCK-HERTZ EXPERIMENT

The quantization of energy and the generation, recording and evaluation of spectra, along with the experimental verification thereof, is included in most of the curricula used around the world. The well known experiment first performed by *James Franck* and *Gustav Hertz* in 1913 is critically important in terms of demonstrating discrete energy states in atoms.